



Section: 11

Washer Parts

SWD Accessories T-450

| Key | Description | Part Number | Qty |
|-----|---|--------------|-----|
| * | Hose, Water Supply 3/8" I.D. x 48" | 9990-027-011 | 2 |
| * | Washer, Inlet Hose (furnished) | 8641-242-000 | 2 |
| * | Strainer, Inlet Hose (furnished) | 9565-003-001 | 1 |
| * | Sealing compound | 8538-151-002 | 1 |
| * | TORX#20 | 8545-051-002 | 1 |
| * | Flow Restrictors (in dispenser) | 9475-002-003 | 3 |
| * | Battery 3V Lithum (used on Control PCB) | 8612-001-001 | 1 |
| * | OPL Bearing & Seal Kit | 9732-219-005 | 1 |
| * | Mounting Base 4" | 9945-110-001 | 1 |
| * | Mounting Base 6" | 9945-111-001 | 1 |
| * | Kit, Door Gasket Expander (small) | 9732-139-001 | 1 |
| * | Kit, Door Gasket Expander (large) | 9732-139-002 | 1 |
| * | Bevel Washer for 3/4" bolt used in installations using angle iron bases | 8641-586-003 | 4 |
| * | Mode Light Support | 9635-022-001 | 1 |

Wiring Harnesses Parts

| Key | Description | Part Number | Qty |
|-----|---|--------------|-----|
| 1 | Add Bleach Light, (Wiring Harness included) | 9794-001-001 | 1 |
| 2 | Wiring Harness, Door Lock P15/P4 | 9627-816-002 | 1 |
| 3 | Wiring Harness, Optional Relay Board (Soap Injection) | 9627-835-001 | 1 |
| * | Wiring Harness, Optional Relay Board to Soap Injection terminal block | 9627-799-002 | 1 |
| 4 | Wiring Harness, Drain,Thermo,Door Gear Motor P17 | 9627-820-002 | 1 |
| 5 | Data Cable | 9806-015-002 | 1 |
| 6 | Wiring Harness P20/P21 | 9627-818-002 | 1 |
| 7 | Wiring Harness P8/P16 | 9627-819-001 | 1 |
| 8 | Wiring Harness WaterValve/P19 | 9627-795-004 | 1 |
| 9 | Wiring Harness LED PCB | 9627-821-001 | 1 |
| * | Wire Yellow Jumper (water valve) | 8220-123-001 | 1 |
| * | Harness Power Terminal Block | 9627-747-003 | 1 |
| 10 | Harness-Extention, Transformer | 9627-826-001 | 1 |
| 12 | Harness-P5/Pressure Switch | 9627-823-001 | 1 |
| * | Circuit Breaker 7 AMP | 5198-211-002 | 1 |
| * | Wiringlabel-schematic | 9506-831-001 | 1 |

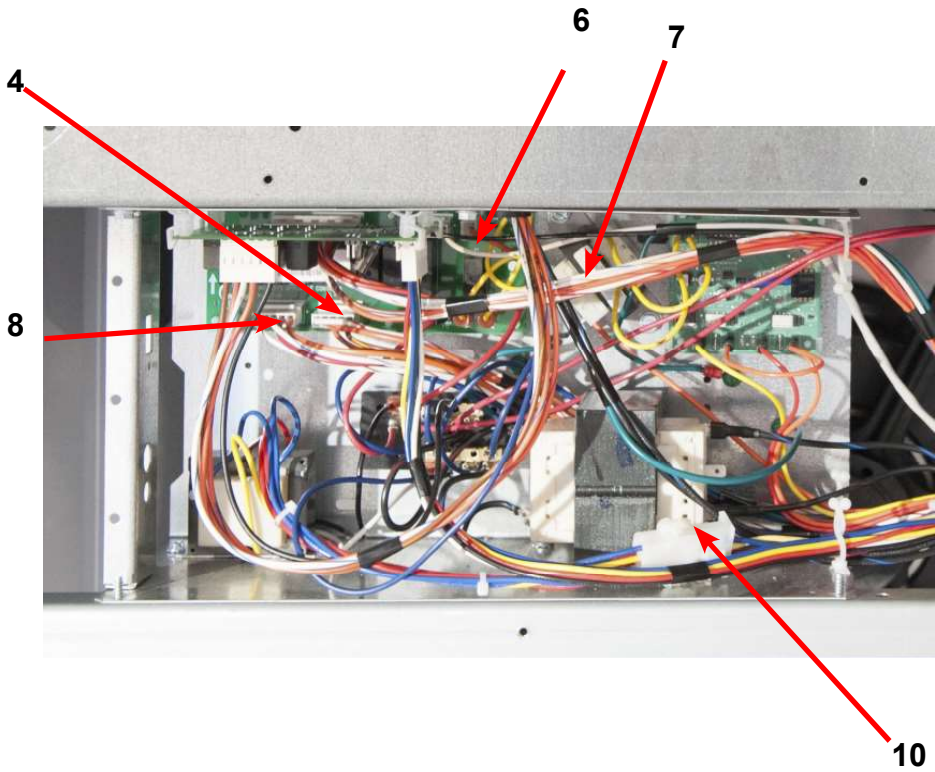
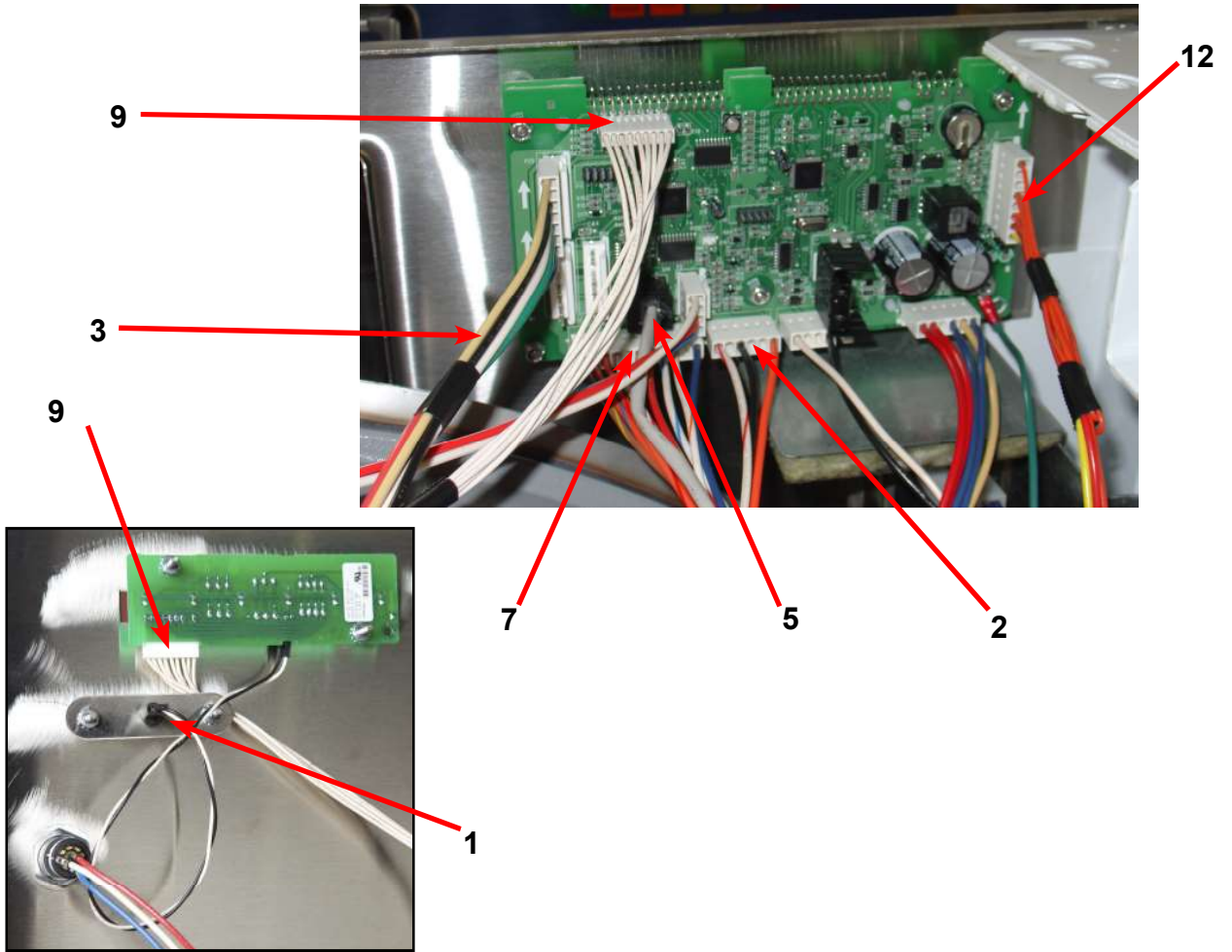

WNS450XA Rear View Access Parts Group

| Key | Description | Part Number | Qty |
|-----|--|--------------|-----|
| 1 | Drive Motor, 3 Phase (Inverter duty) | 9376-319-001 | 1 |
| 2 | Rod, Motor Mtg | 9497-222-006 | 1 |
| 3 | Motor Bushing (Rubber) | 9053-082-001 | 2 |
| * | Clamp-Worm, 316SS, 1.5" (for Rubber bushing) | 8654-117-019 | 2 |
| 4 | Strap Bracket, Motor Tension | 9029-206-002 | 1 |
| * | Nut, Strap to Motor | 8640-413-002 | 1 |
| * | Washer | 8641-581-006 | 1 |
| 5 | Spring, Belt Tension | 9534-319-002 | 1 |
| * | Pulley, Motor | 9453-170-003 | 1 |
| * | Set Screw,Sq.Hd(motor pulley) | 9545-028-015 | 2 |
| * | Tolerance Ring | 9487-234-003 | 1 |
| 6 | Pulley, Driven | 9453-168-003 | 1 |
| * | Screw 5/8-11x1/2" | 9545-060-001 | 1 |
| * | Lockwasher 5/8" | 8641-582-018 | 1 |
| * | Washer, Flat 5/8x2 1/4" | 8641-581-032 | 2 |
| 7 | Drive Belt | 9040-077-003 | 2 |
| 8 | Channel, Rear | 9081-190-001 | 1 |
| * | Screw | 9545-008-026 | 4 |
| * | Nut, Spring | 8640-399-001 | 4 |
| * | Hose, Overflow to drain | 9242-449-004 | 1 |
| * | Clamp, Hose overflow to drain | 8654-117-009 | 2 |
| 9 | Hose, Overflow Vent Top | 9242-463-005 | 1 |
| * | Clamp, Hose Vent | 8654-117-014 | 1 |
| 10 | Vaccum Breaker | 9610-001-002 | 1 |
| 11 | Bracket, Vacuum Breaker | 9029-121-001 | 1 |
| 12 | Screw, 10B x 1/2 | 9545-008-026 | 4 |
| * | Vacuum Breaker Cap | 0935-135-002 | |
| 13 | Injector assembly soap | 9883-008-001 | 1 |
| * | Cap-injectorassembly | 0935-127-001 | 1 |
| * | Hose-injectorassembly | 9242-461-001 | 1 |
| * | Hose-injectionasy,2"diameter | 9242-462-001 | 1 |
| * | Plastic Plug 7/8" Electrical Connection | 9456-041-006 | 1 |
| * | Panel Assy., Back | 9454-966-001 | 1 |
| * | Screw Panel Mtg.#10Bx1/2" | 9545-008-026 | 10 |
| * | Screw Panel Mtg.#10Bx1/2" | 9545-030-002 | 3 |
| * | Nut, Spring | 8640-399-001 | 8 |
| 14 | Hose, Pressure Switch | 9242-175-005 | 1 |
| * | Clamp, Pressure Switch Hose | 8654-117-015 | 1 |
| 15 | VFD Delta "E" drive 208-240 volt | 9375-030-017 | 1 |
| * | Braking resistors (200 ohm) | 9483-004-002 | 2 |
| 16 | Bracket assembly (drive mounting) | 9029-119-002 | 1 |

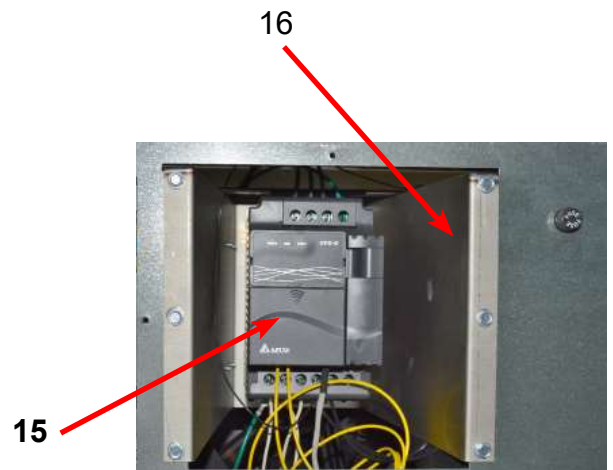
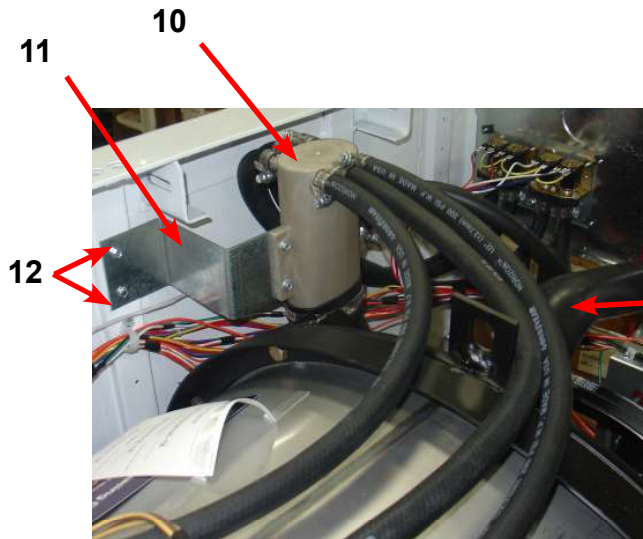
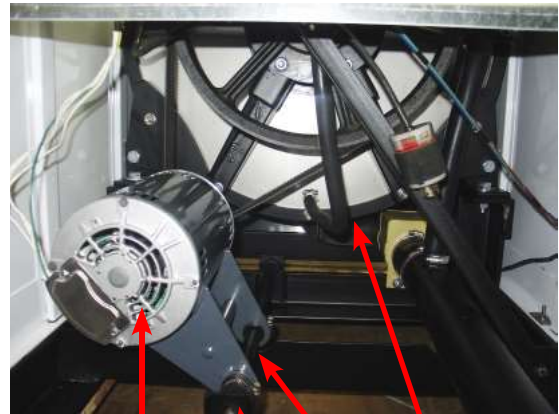
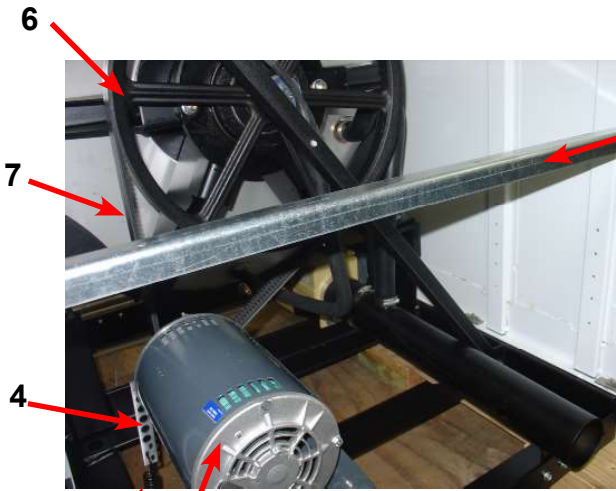

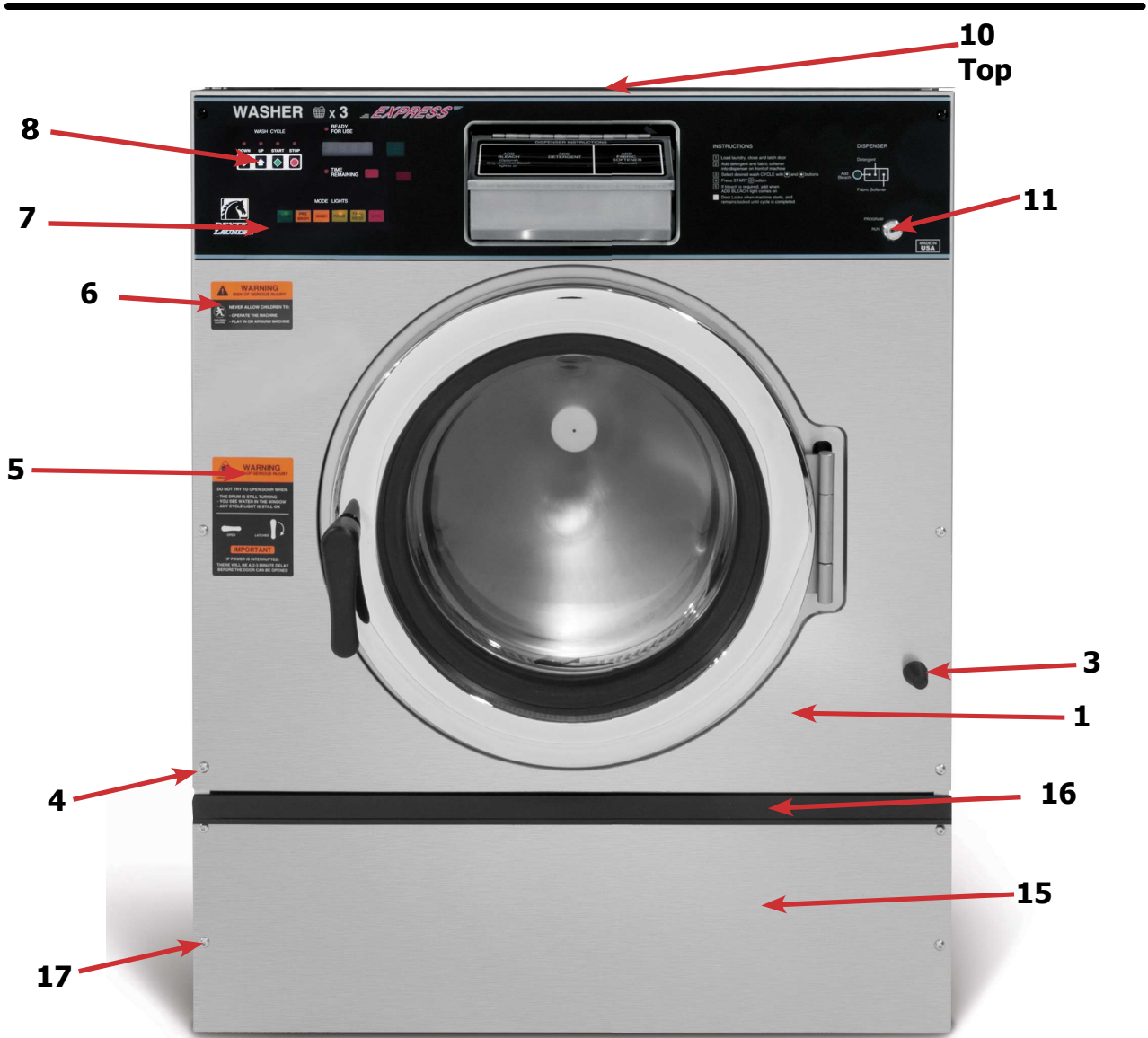

Cabinet and Front Panel Group

| | Description | Part Number | Qty |
|----|--|--------------|-----|
| * | Panel, Right Side-Painted | 9989-604-002 | 1 |
| * | Panel, Left Side - Painted | 9989-605-002 | 1 |
| * | Strap assy-studs | 9966-017-001 | 4 |
| * | Shim-Side Panels | 9552-048-001 | 2 |
| * | Nut-hex 1/4-20unc,2b | 8640-414-006 | 10 |
| 1 | Panel Assy, Front | 9989-607-001 | 1 |
| 3 | Bumper Loading Door | 9051-055-001 | 1 |
| 4 | Screw, 10bx1 3/4 | 9545-008-014 | 6 |
| * | Washer Finish | 8641-585-001 | 6 |
| * | Nut, Spring-To Front Panel | 8640-399-001 | 6 |
| 5 | Label, Door Opening, Black | 8502-757-001 | 1 |
| 6 | Label, Risk of Injury, Black | 8502-759-001 | 1 |
| 7 | Nameplate Decal, Control Panel, Black | 9412-232-001 | 1 |
| 8 | Button, Push Control, Black | 9035-060-004 | 1 |
| 10 | Panel Top, Front, Painted | 9989-608-002 | 1 |
| * | Screw, Hex, #10B x 1/2 | 9545-008-026 | 14 |
| * | Cover Top Rear | 9454-965-001 | 1 |
| * | Screw, Hex, #10B x 1/2 | 9545-008-026 | 4 |
| 11 | Lock-Run/program w/harness | 8650-027-001 | |
| 12 | Soap Dispenser Assembly, Complete (Does not include lid) | 9807-087-001 | 1 |
| * | Soap Box mounting Gasket | 9206-425-001 | 1 |
| 13 | Lid Assembly soap box | 9987-104-001 | 1 |
| * | Lid screws #10-32x1/2 SS | 9545-012-017 | 2 |
| * | Nut Hex Elasticstop #10-32 SS | 8640-413-006 | 6 |
| * | Bracket Soap box mounting | 9029-122-002 | 1 |
| * | Softner siphon tube (plastic) | 9574-252-002 | 1 |
| * | Flow restrictors | 9475-002-003 | 3 |
| 14 | Label, Dispenser Instructions, Black | 8502-745-001 | 1 |
| 15 | Door, Lower Service | 9108-145-001 | 1 |
| 16 | Handle, Lower Service Door | 9244-086-005 | 1 |
| 17 | Screw, 10bx 1 3/4 | 9545-008-020 | 4 |
| * | Washer Finish | 8641-585-001 | 6 |

WSN450XA Cylinder, Seals & Bearings

| | Description | Part Number | Qty |
|----|--|--------------|-----|
| * | Housing, Bearing- Assembly (items #2-#6) | 9803-186-001 | 1 |
| 2 | Housing, Bearing | 9241-180-002 | 1 |
| 3 | Bearing, Front (LARGE) | 9036-159-005 | 1 |
| 4 | Bearing, Rear (SMALL) | 9036-159-004 | 1 |
| 5 | Spacer, Bearing | 9538-167-001 | 1 |
| 6 | Ring, Bearing Retainer | 9487-238-003 | 1 |
| 8 | Seal, Primary | 9532-140-009 | 1 |
| 9 | Seal, Secondary | 9532-140-006 | 1 |
| 10 | Ring, Seal Mounting | 9950-048-001 | 1 |
| 11 | Tub Back Mating Ring | 9487-261-003 | 1 |
| 12 | Bolt 5/8-11x1 1/2" Tub end of bearing Housing | 9545-060-001 | 6 |
| 12 | Nut 5/8"-11 | 8640-425-001 | 6 |
| 13 | Support Arm Assy, Bearing Housing | 9991-056-002 | 6 |
| 14 | Bolt Pulley end of bearing housing, 7/16-14x2" | 9545-059-003 | 6 |
| * | Nut, Flange Locking 7/16" | 8640-416-005 | 6 |
| 15 | Pulley, Driven | 9453-168-003 | 1 |
| 16 | Ring, Tolerance | 9487-234-003 | 1 |
| 17 | Washer 5/8"x 2 1/4" | 8641-581-032 | 2 |
| 18 | Bolt 5/8-11x1 1/2" | 9545-060-001 | 1 |
| 19 | Lockwasher 5/8 Ext. tooth | 8641-582-018 | 1 |
| * | Cylinder Assy | 9848-120-001 | 1 |
| * | Tub and Cylinder Assy. | 9869-034-001 | 1 |
| * | Plastic Plug 1 1/2"-(inside cylinder) | 9456-041-007 | 1 |

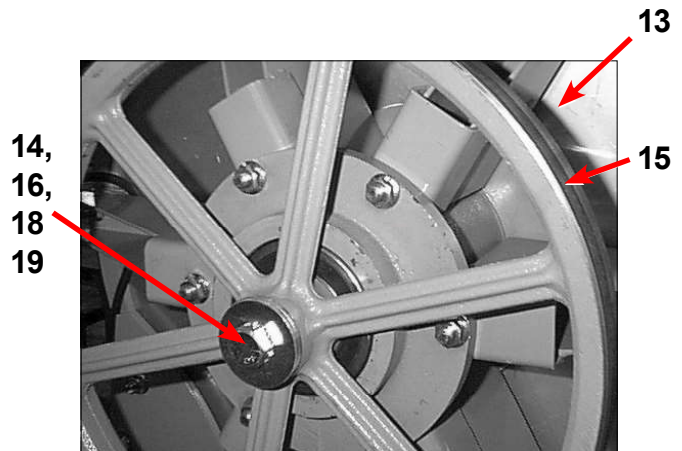
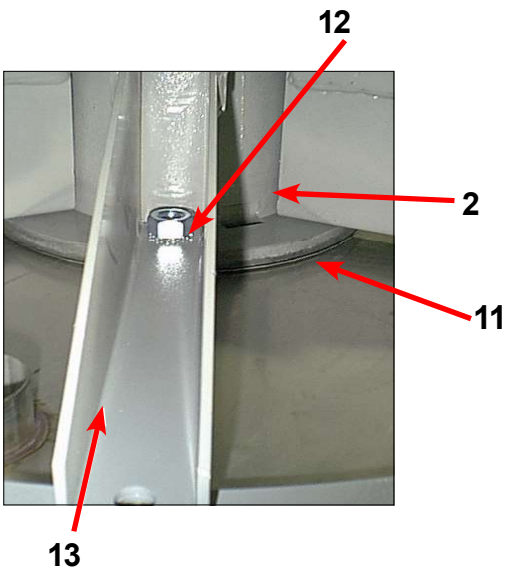
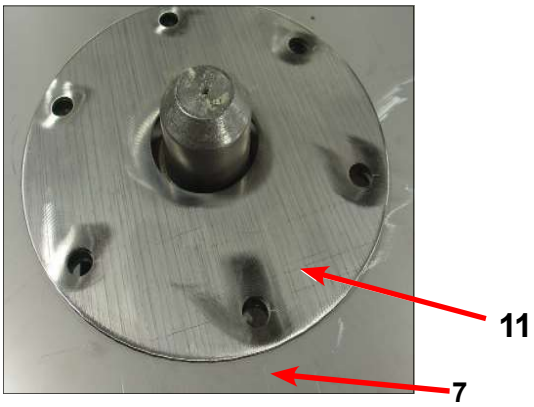
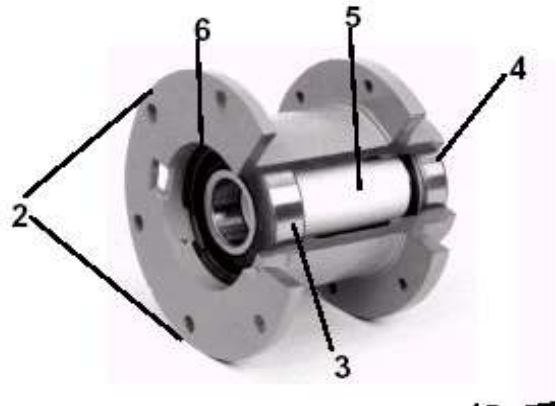
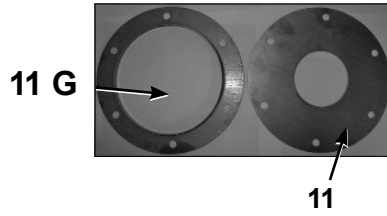
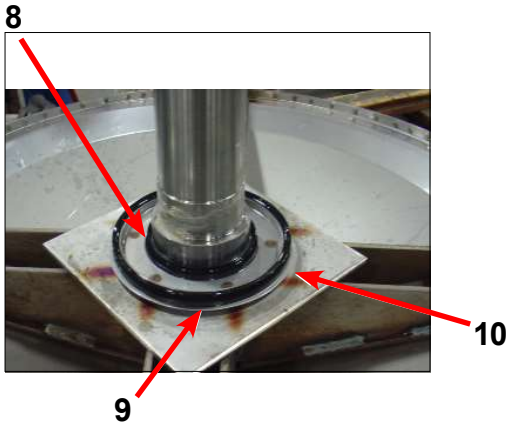
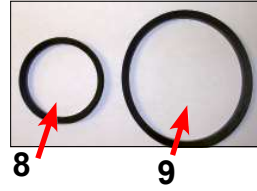
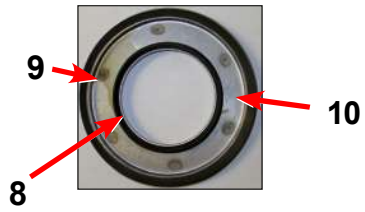

Door Lock Assembly (continued)

| Key | Description | Part Number | Qty |
|-----|---|--------------|-----|
| 33 | Lock Assy, Complete (#1-22)(includes #1 thru #22) | 9885-024-001 | 1 |
| 1 | Plate Assy, Door Lock | 9982-346-001 | 1 |
| 2 | Washer, Flat | 8641-581-030 | 1 |
| 3 | Actuator, Latching Switch | 9008-005-001 | 1 |
| 4 | Pawl, Locking | 9450-002-004 | 1 |
| 5 | Washer, Spring | 8641-569-003 | 1 |
| 6 | Ring, Retaining | 9487-200-004 | 1 |
| 7 | Bracket Switch | 9029-163-001 | 1 |
| 8 | Nut, Hex 10-32 UNF | 8640-413-002 | 2 |
| 9 | Spring, Actuating | 9534-364-002 | 1 |
| 10 | Screw, Hx. 10-32 x 1" | 9545-012-020 | 1 |
| 11 | Nut, Elastic Stop 10-32 | 8640-413-004 | 2 |
| 12 | Spring, Return | 9534-364-001 | 2 |
| 13 | Pin, Guide | 9451-193-001 | 1 |
| 14 | Ring, Retaining | 9487-200-005 | 1 |
| 15 | Washer | 8641-581-031 | 1 |
| 16 | Switch, Latching Sensing | 9539-461-008 | 1 |
| 17 | Shield, Switch | 9550-169-003 | 3 |
| 18 | Screw 4-40 x 5/8" | 9545-020-001 | 2 |
| 18 | Nut, Twin | 8640-401-001 | 1 |
| 19 | Switch, Locking Sensing | 9539-461-007 | 2 |
| 20 | Actuator, Switch Locking | 9008-006-003 | 1 |
| 21 | Screw 4-40 x 1 1/8" | 9545-020-003 | 2 |
| 21 | Nut, Twin 4-40 | 8640-401-001 | 1 |
| * | Shim, Door Lock, Thin | 9552-037-001 | AR |
| * | Screw, Lock mtg 1/4"-20 x 3/4" | 9545-018-014 | 3 |
| * | Lockwasher 1/4" Ext tooth | 8641-582-007 | 3 |

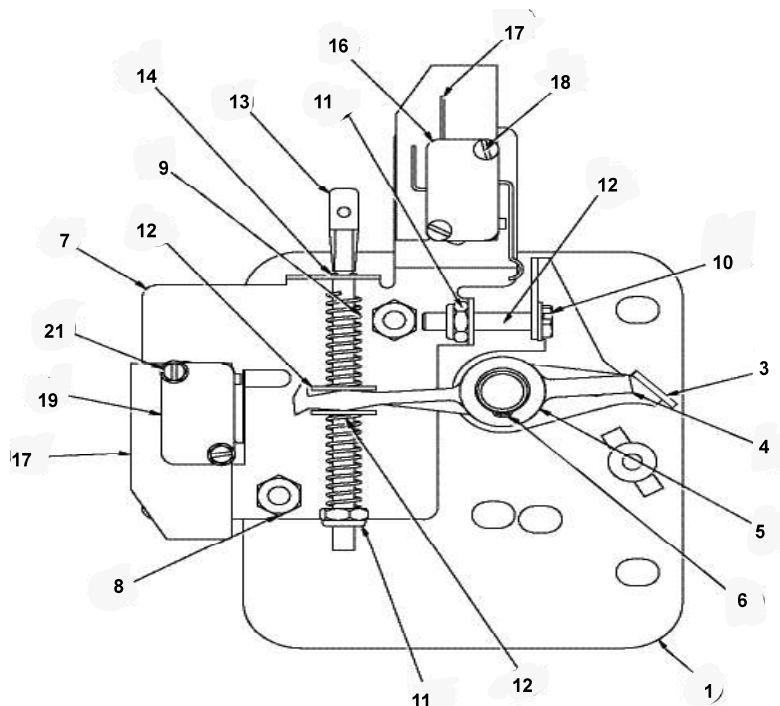

Gear Motor Door Lock Assembly

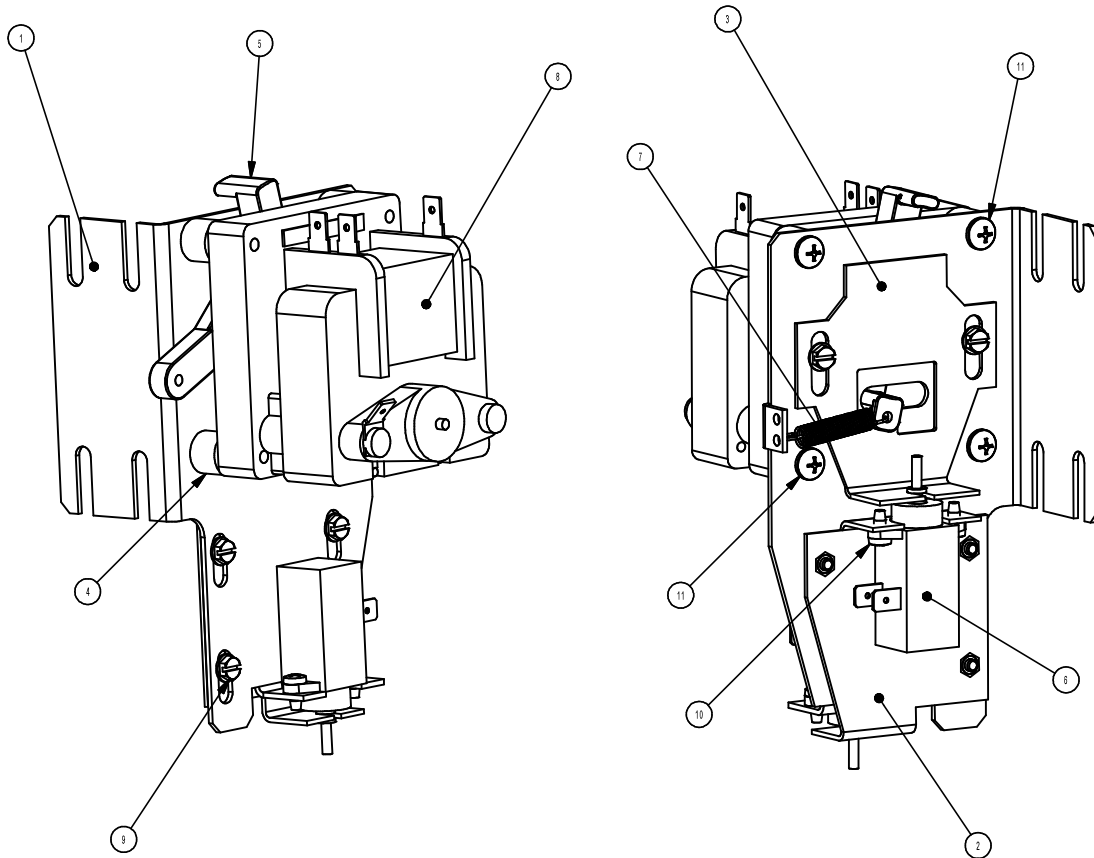

| Key | Description | T750 | QTY |
|-----|---|--------------|-----|
| * | Actuator Assembly (Includes 1-10, Rod NOT included) | 9892-017-002 | 1 |
| 1 | Bracket Assy, Slide Lock Actuator | 9985-199-001 | 1 |
| 2 | Bracket Assy, Slide - Unlock | 9985-196-001 | 1 |
| 3 | Bracket Slide Lock | 9029-278-001 | 1 |
| 4 | Spacer, Plastic | 9538-157-021 | 4 |
| 5 | Arm - Door Lock | 9001-063-001 | 1 |
| 6 | Thermoactuator - Door Lock Relay 24v | 9586-001-003 | 2 |
| 7 | Spring - Extension | 9534-350-001 | 1 |
| 8 | Motor & Gear Assembly 24v | 9914-137-014 | 1 |
| 9 | Screw -Hxwshrhdslsems, 6-32 x 3/16 | 9545-044-003 | 6 |
| 10 | Cross Recessed PAn Hd Tapping screw | 9545-031-011 | 4 |
| 11 | Screw Pnhdcr, 10-32 UNFx0 .75 | 9545-012-029 | 4 |
| * | Rod, Door Lock | 9497-225-018 | 1 |
| * | Harness, Door Lock/Drain, P17 | 9627-816-003 | 1 |

Large Door & Hinge Group

| Key | Description | T450 | QTY |
|-----|--|--------------|-----|
| 1 | Door Hinge Assembly (mounts to tub front) | 9955-030-001 | 1 |
| * | Door Assembly Complete | 9960-309-001 | 1 |
| 2 | Door Ring 180 degree large hinge | 9487-265-002 | 1 |
| 3 | Door Gasket | 9206-419-001 | 1 |
| 4 | Door Glass Window | 9635-016-001 | 1 |
| * | Red Wire (Door Close Switch) | 8220-063-025 | 1 |
| * | Black Wire (Door Close Switch) | 8220-063-026 | 1 |
| 5 | Switch, Door Hinge Close (Plunger) | 9539-492-001 | 1 |
| 6 | Top Door Hinge Leaf | 9845-008-001 | 1 |
| 7 | Bottom Door Hinge Leaf | 9845-005-002 | 1 |
| 8 | Thrd Form Screw, Door Mtg 5/16" x 5/8" | 9545-056-002 | 3 |
| 9 | Screw, Loading Door Hinge Mtg (5/16" x3/4" ss) | 9545-014-009 | 3 |
| 9 | Lock Washer, exttooth 5/16 | 8641-582-009 | 3 |
| * | Shim Large door | 9552-037-001 | 1 |

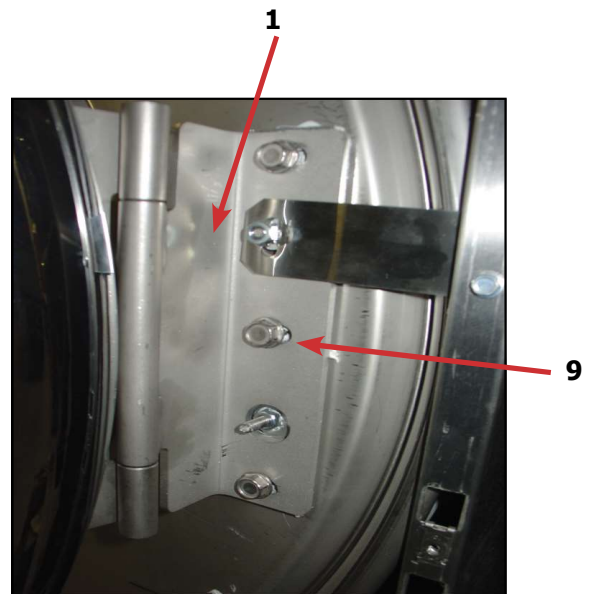

| Key | Description | T450 | QTY |
|-----|-------------------------------------|--------------|-----|
| * | Shaft Assembly-Loading Door (11-14) | 9913-134-003 | 1 |
| 11 | Shaft, Door Locking | 9537-195-002 | 1 |
| 12 | Cam, Locking | 9095-040-002 | 1 |
| 13 | Pin, Groove (1 1/4) | 9451-181-005 | 1 |
| 14 | Pin, Groove (3/4) | 9451-181-004 | 1 |
| 15 | Spring, Lock Cam | 9534-360-002 | 1 |
| 16 | Handle, Door | 9244-091-001 | 1 |
| 17 | Pin, Door Handle (groove) | 9451-181-005 | 1 |

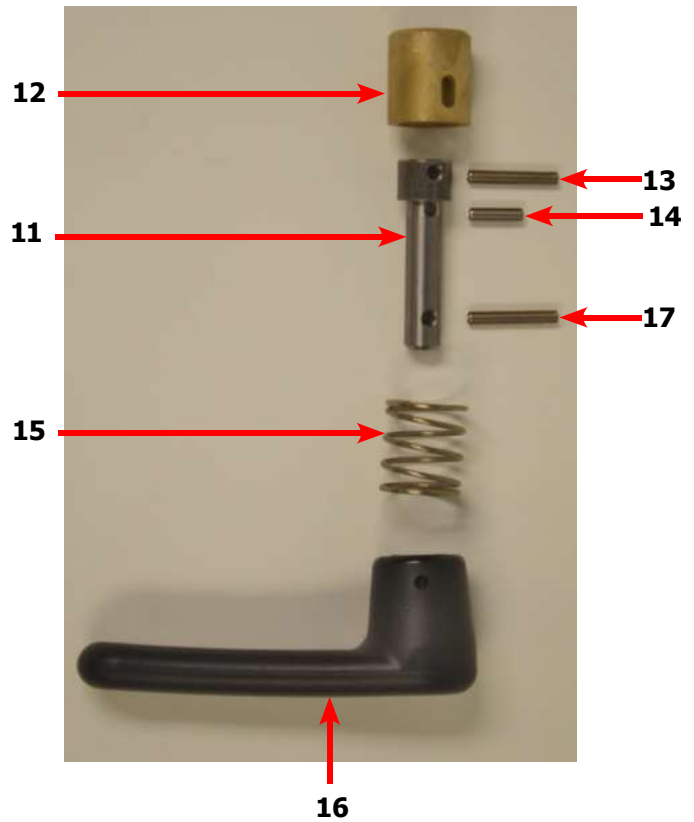
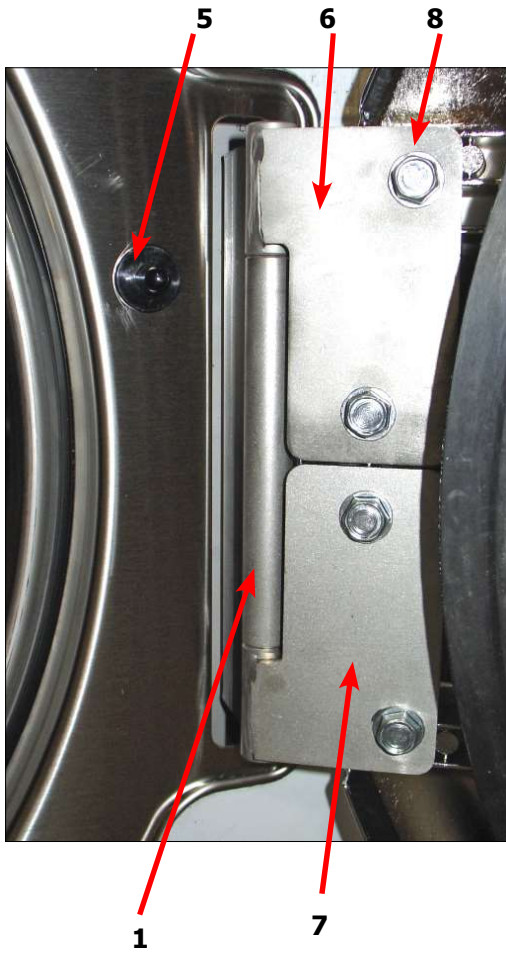

Drain Valve Group Part # by Model

| Key | Description | Part Number | Qty |
|-----|-------------------------------------|--------------|-----|
| 1 | Valve, Drain (includes #2 thru #11) | 9379-202-002 | 1 |
| 2 | Body, Valve (w/ball) | 9064-072-001 | 1 |
| 3 | Motor & Gear Train (complete) | 9914-137-022 | 1 |
| 4 | Plate, Motor Mtg | 9452-538-001 | 1 |
| 5 | Screw | 8639-994-001 | 1 |
| 6 | Spring, Drive | 9534-339-001 | 1 |
| 7 | Screw | 9545-054-001 | 1 |
| 8 | Screw | 9545-054-002 | 1 |
| 9 | Seal, V Packer | 9532-134-001 | 1 |
| 10 | Washer | 8641-584-001 | 1 |
| 11 | Pin, Main Drive | 9451-196-001 | 1 |
| 12 | Kit - Seal Replacement | 9732-327-001 | 1 |

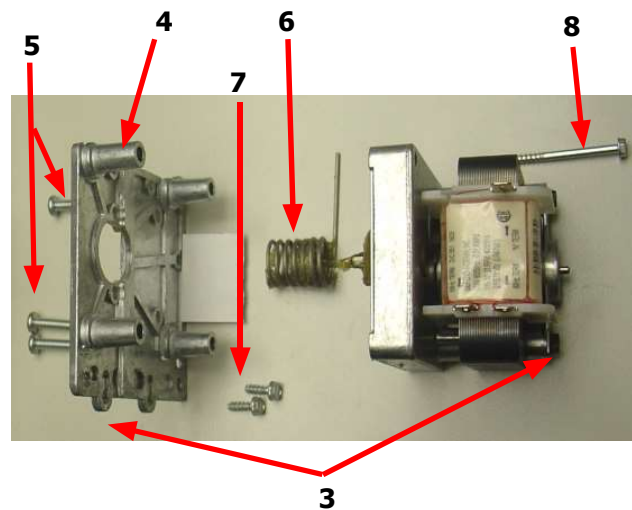
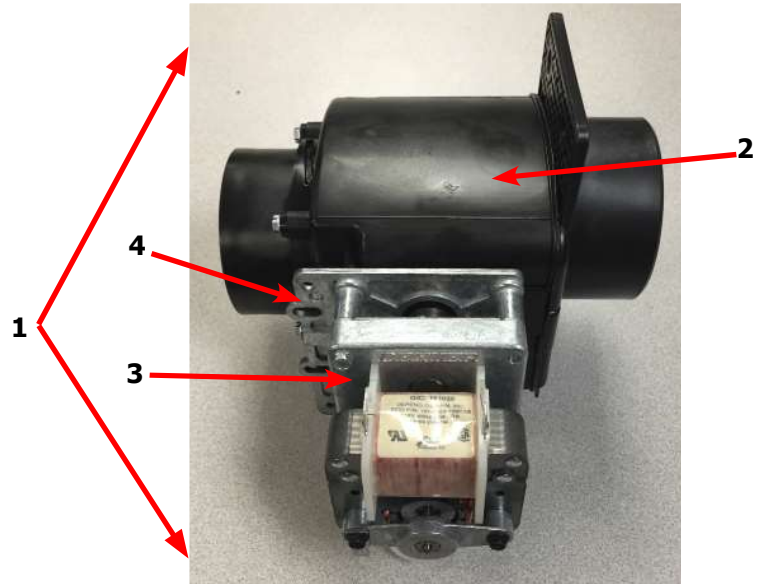
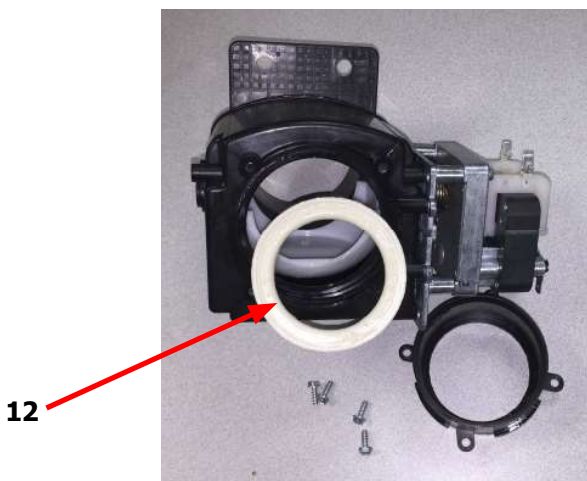

Water Inlet Valve Breakdown

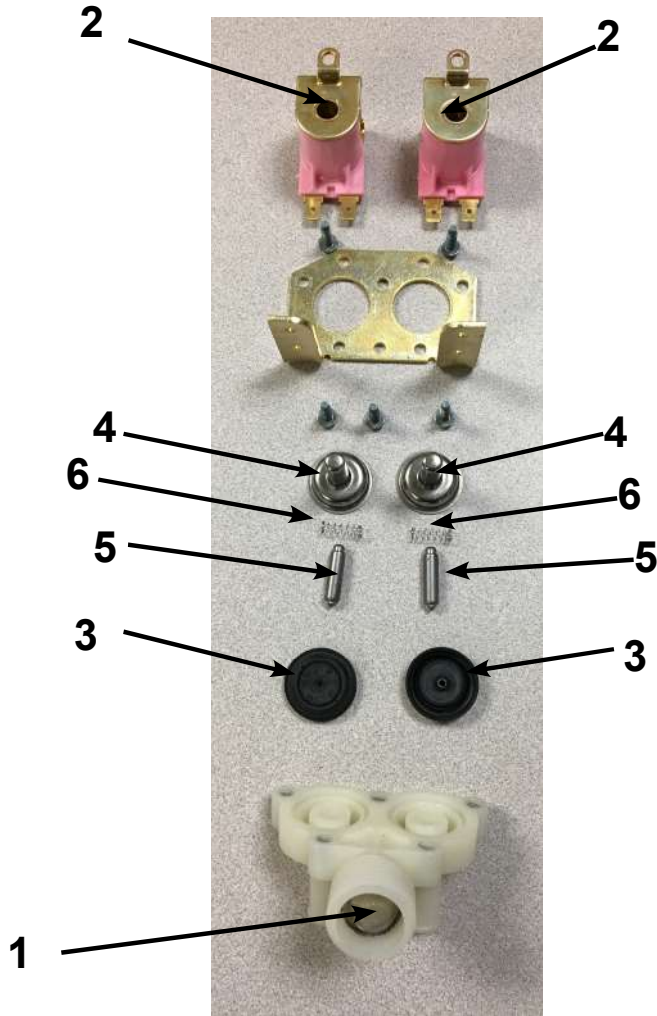

| Key | Description | Part Number | QTY |
|-----|--|--------------|-----|
| * | Valve, Water Inlet (includes 1 thru 6) - Invensys | 9379-183-013 | 2 |
| 1 | Screen, Inlet end of valve | 9555-056-001 | 2 |
| 2 | Coil Assy., 24 V Invensys | 9089-017-004 | 2 |
| 3 | Diaphragm Invensys (EPDM) | 9118-049-003 | 2 |
| 4 | Guide, Solenoid Invensys | 9211-021-002 | 2 |
| 5 | Armature Invensys | 9015-008-001 | 2 |
| 6 | Spring, Armature Invensys | 9534-298-001 | 2 |

WNS450XA Chassis and Drain by Part

| Key | Description | Part Number | Qty |
|-----|---|--------------|-----|
| 1 | Base Assy,Frame | 9945-150-002 | 1 |
| * | Outer Tub Assy | 9930-166-001 | 1 |
| * | Cylinder Assembly, (Includes Spider) | 9848-120-001 | 1 |
| 3 | Back Ass'y, Tub | 9962-013-003 | 1 |
| 4 | Bolt, 7/16" x 2" Tub Back to Tub | 9545-059-002 | 12 |
| 5 | Nut, Flange Lock | 8640-416-005 | 12 |
| * | Bolt, 5/8-11 x 1 1/2 Tub to Base, Front | 9545-060-001 | 2 |
| * | Nut, 5/8-11 Wizlok | 8640-425-001 | 2 |
| * | Ring Assy, Tub Mtg-Front | 9950-051-004 | 1 |
| * | Bolt, Top Front Ring 5/8" x 3" | 9545-017-016 | 1 |
| * | Nut WCAD 5/8" | 8640-417-005 | 1 |
| 6 | Ring Assy.Clamp Tub Mtg.- Rear | 9950-056-002 | 1 |
| 7 | Bolt, 5/8-11 x 1 1/2 Tub to Base, Rear | 9545-060-001 | 2 |
| 8 | Nut, 5/8-11 Wizlok | 8640-425-001 | 2 |
| 9 | Bolt, 5/8-11 x 2 Tub & Rings to Base, Front & Rear | 9545-060-004 | 4 |
| 10 | Washer | 8641-581-038 | 4 |
| 11 | Nut, 5/8-11 Wizlok | 8640-425-001 | 4 |
| 12 | Hose, Overflow | 9242-449-004 | 1 |
| 13 | Clamp | 8654-117-009 | 2 |
| 14 | Tube, Over Suds | 9242-463-005 | 1 |
| * | Clamp | 8654-117-014 | 1 |
| 15 | Hose, Tub to Drain Valve | 9242-464-001 | 1 |
| 16 | Valve, Drain | 9379-202-001 | 1 |
| * | Screw, Valve to Bracket 5/16-18x1 1/4 | 9545-014-012 | 2 |
| * | Nut, 5/16-18 | 8640-400-003 | 2 |
| 17 | Hose, Drain Valve to Tube | 9242-457-001 | 1 |
| * | Clamp, Hose (Drain Valve to Tube)&(Srain Hose to Valve) | 8654-117-009 | 2 |
| * | Screw Tube (Bracket to Base 1/4B x 3/4) | 9545-030-002 | 2 |
| 18 | Tube Assy, Drain | 9915-122-002 | 1 |
| 19 | Injector assembly soap | 9883-008-001 | 1 |
| * | Clamp | 8654-117-014 | 2 |
| * | Cap-injectorassembly | 0935-127-001 | 1 |
| * | Hose-injectorassembly | 9242-461-001 | 1 |
| 20 | Hose-injectionasy,2"diameter | 9242-462-001 | 1 |



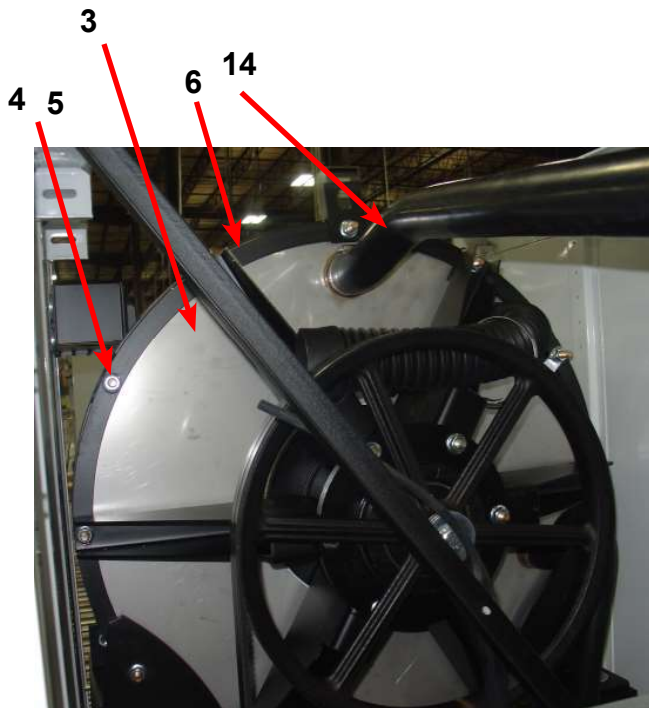
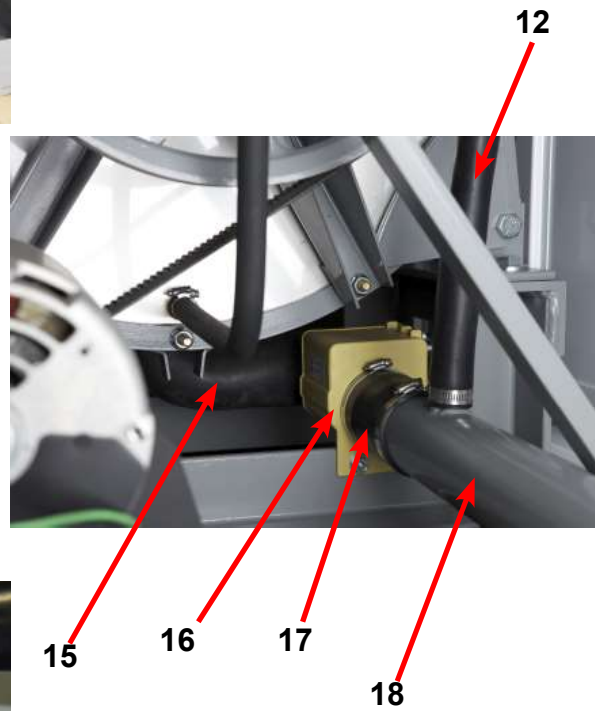
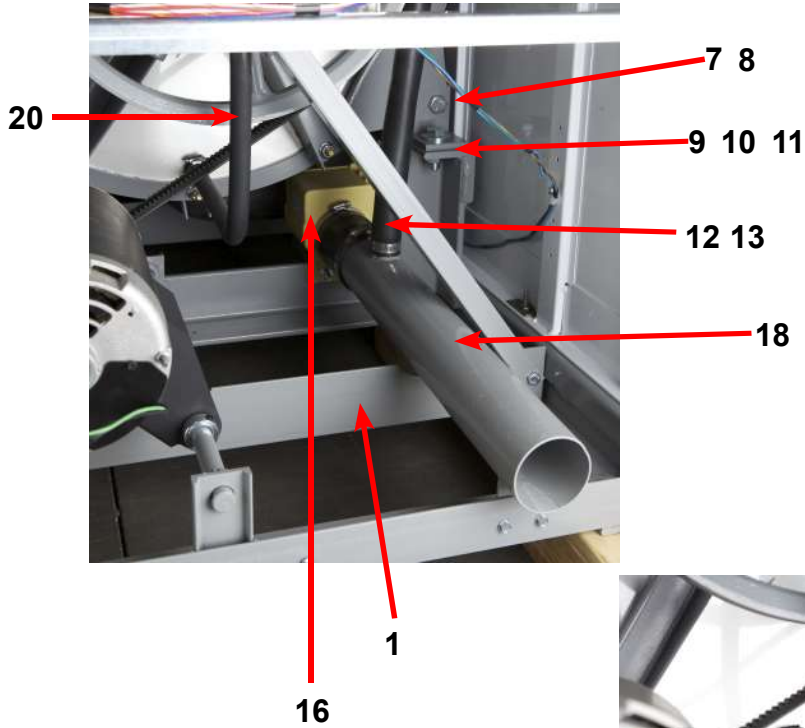

Electrical Components, Control Trough

| Key | Description | Part Number | Qty |
|-----|--|--------------|-----|
| 1 | Trough Assy,Controls 208-240 volt | 9857-236-001 | 1 |
| | Trough only | 9839-018-001 | 1 |
| 2 | Transformer, Control (208/230/60 Hz In 24 VAc Out Volts) | 8711-004-004 | 1 |
| * | Wire Assembly, Red 28" | 8220-062-025 | 2 |
| * | Screw, #10B x 1/2 | 9545-008-026 | 4 |
| * | Lockwasher Exttooth #10 | 8641-582-006 | 4 |
| * | Wire Assembly, BLK/BLU | 8220-001-233 | 1 |
| * | Wire Assembly, BLK/RED | 8220-001-232 | 1 |
| 3 | Terminal Block Assy, POWER | 9897-026-004 | 1 |
| * | Screw, Mtg 8Bx1/2" | 9545-045-012 | 2 |
| * | Harness-extention, Transformer | 9627-826-001 | 1 |
| * | Screw, 8B x 1/4 | 9545-045-001 | 2 |
| * | Lockwasher-External Tooth, #10 | 8641-582-006 | 2 |
| * | Wire Assembly, P12, Red 7" | 9631-381-018 | 1 |
| 4 | PCB assembly Relay Main | 9473-006-001 | 1 |
| * | PCB support 3/8 edge Holding | 9548-285-001 | 10 |
| * | Wiring Harness, Door Lock P15/P4 | 9627-816-003 | 1 |
| * | Wiring Assembly Yel. 32" P14 & P13 | 8220-064-023 | 2 |
| 5 | Wiring Harness, Drain,Thermo,Door Gear Motor P17 | 9627-820-002 | 1 |
| 6 | Wiring Harness WaterValve/P19 | 9627-795-004 | 1 |
| 7 | Wiring Harness P8/P16 | 9627-819-001 | 1 |
| * | Wiring Harness P20/P21 | 9627-818-002 | 1 |
| 8 | Sensor-Pressure Switch | 9732-315-001 | 1 |
| 9 | Harness Assembly, Pressure Switch | 9627-823-001 | 1 |
| 10 | Wiring Harness-Main | 9627-914-002 | 1 |
| 11 | Transformer | 8711-010-003 | 1 |
| 12 | Optional Relay board | 9473-007-001 | |

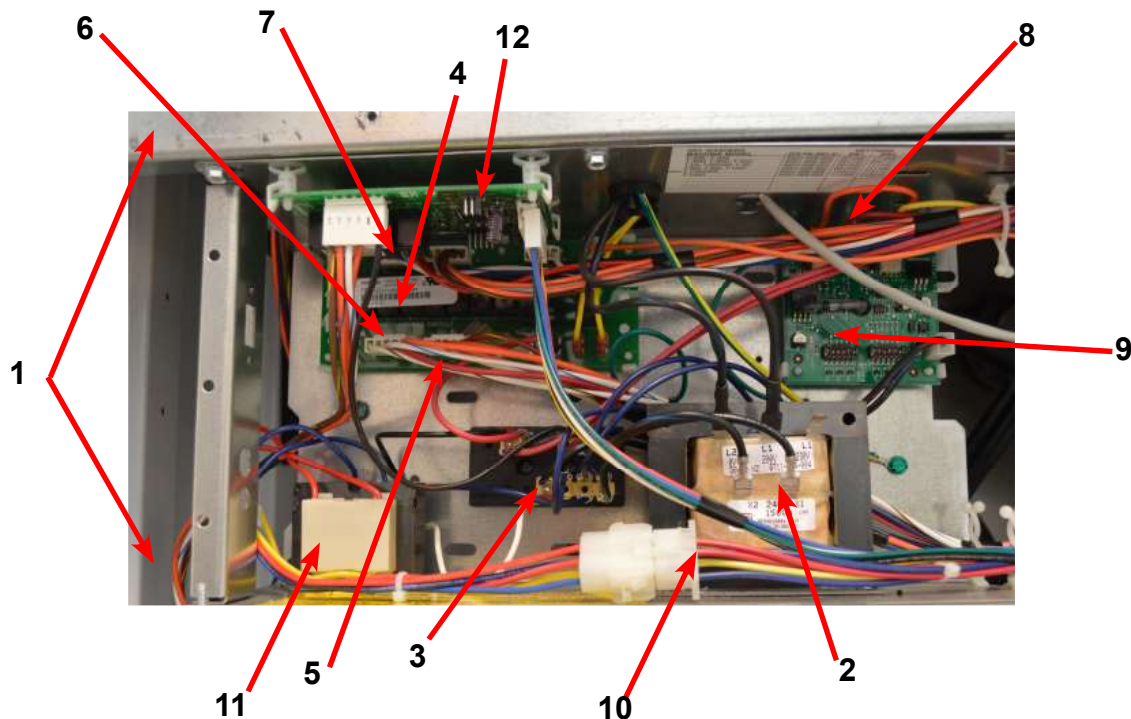

Electrical Components, Upper Channel

| Key | Description | Part Number | Qty |
|-----|--|--------------|-----|
| 1 | Terminal Block Assy, POWER | 9897-033-002 | 1 |
| * | Screw, Mtg 6ABx3/4" | 9495-031-010 | 2 |
| 2 | Strip, Terminal Marker | 9558-025-001 | 1 |
| 3 | Terminal, Lug-Solderless (Ground) | 8652-134-001 | 1 |
| * | Screw, 10-32TTx1/2 Green (Control Trough) | 9545-008-027 | |
| * | Wiring Harness Power Terminal To VFD & Control Transformer and ground wire | 9627-747-003 | 1 |
| 4 | VFD Delta drive 208-240 volt | 9375-030-017 | 1 |
| * | Cable, Data Communication | 9806-015-002 | 1 |
| * | Wiring Assembly Yel. 32" | 8220-064-023 | 2 |
| 5 | Braking resistors (200 ohm) | 9483-004-002 | 2 |
| * | Wire Assembly-Jumper, BLK (Breaking Resistors) | 8220-117-002 | 2 |
| 6 | Circuit Breaker | 5198-211-002 | 1 |
| 7 | Terminal Block Assy, Injector | 9897-032-002 | 1 |
| 8 | Strip-termmarker | 9558-028-002 | |
| | Screw-pnhdtorx 4bx5/8 ss | 9545-053-002 | |

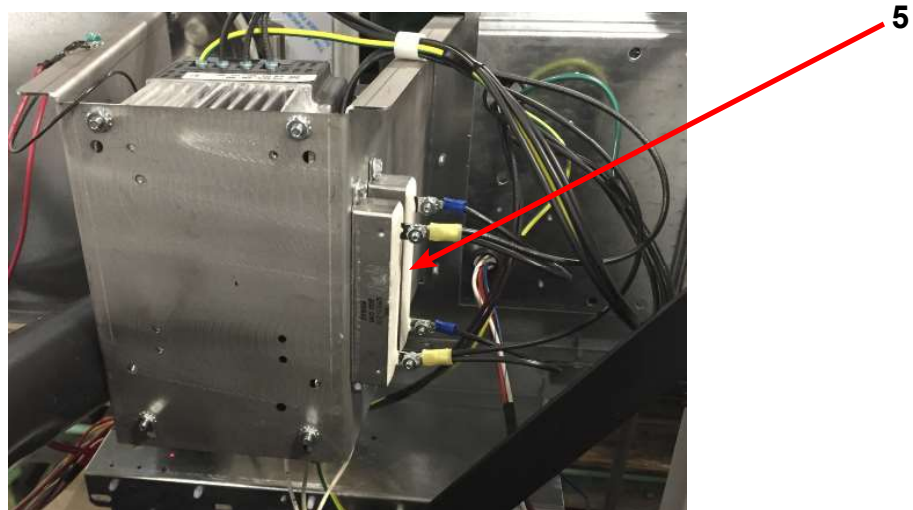
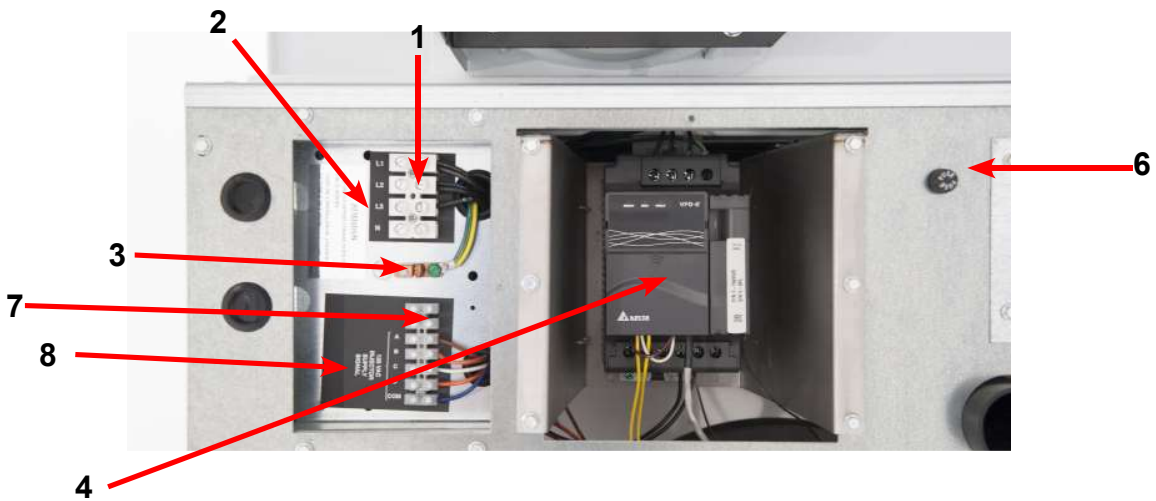

Front Panel Control Group Part

| Key | Description | Part Number | Qty |
|-----|--|--------------|-----|
| * | Nameplate,Control Panel Black(one piece) | 9412-232-001 | 1 |
| 1 | PCB assembly Control /Display | 9473-004-009 | 1 |
| * | Spacer Pushbutton (Micro) | 9538-178-001 | 1 |
| * | Retainer Pushbutton (Micro) | 9486-160-001 | 1 |
| * | Nut Hexelasticstop #4-40 | 8640-424-002 | 2 |
| * | Pushbutton Control | 9035-060-004 | 1 |
| * | Spacer Plastic #6x9/16 | 9538-157-018 | 5 |
| * | Nut Elasticstop #6-32 | 8640-411-002 | 4 |
| * | Nut-Hexkeys, #6-32 | 8640-411-003 | 1 |
| 2 | Harness LEDPCB | 9627-821-001 | 1 |
| 3 | Harness Doorlock, Switches | 9627-816-002 | 1 |
| 4 | PCB assembly Mode lights | 9473-005-001 | 1 |
| * | Spacer Plastic #6x9/16 | 9537-157-018 | 2 |
| * | Nut Hexkeys #6-32 | 8640-411-003 | 2 |
| 6 | Door Locking Actuator 24 volts | 9892-017-002 | 1 |
| * | Hex Nuts (mounting gear motor to control) | 8640-412-005 | 4 |
| 7 | Battery | 8612-001-001 | 1 |
| 8 | Add Bleach Light (Wiring Harness included) | 9794-001-001 | 1 |
| 9 | Lock Run/Program With Harness | 8650-027-001 | |

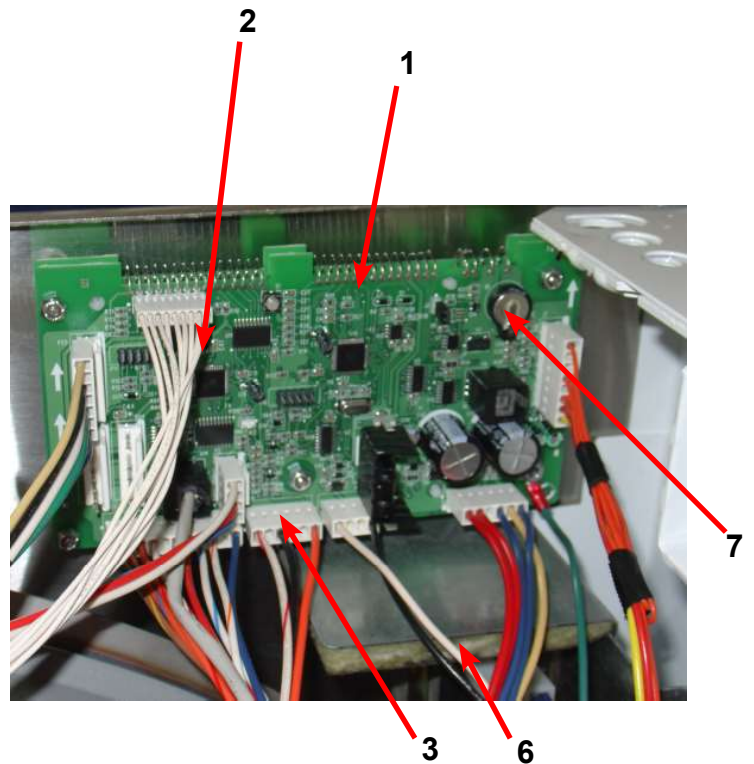
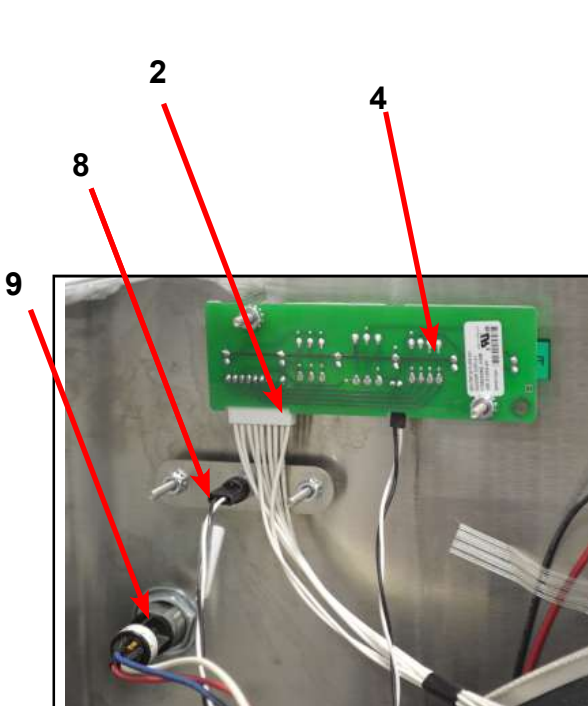

Labels and Diagrams by Part

| Key | Description | Part Number | Qty |
|-----|--------------------------------------|--------------|-----|
| * | Wiring Diagram, OPL | 9506-831-001 | 1 |
| 1 | Label High Voltage Warning | 8502-614-004 | 1 |
| * | Cover controls | 9074-267-001 | 1 |
| 2 | Label Fusing & Installation | 8502-619-004 | 1 |
| 3 | Label Warning Risk of Injury Black | 8502-759-001 | 1 |
| 4 | Label Warning Door Opening Black | 8502-757-001 | 1 |
| * | Booklet Owners | 8514-285-001 | 1 |
| 5 | Label, Dispenser Instructions, Black | 8502-745-001 | 1 |
| 6 | Cover-Motor Control | 9074-268-001 | 1 |

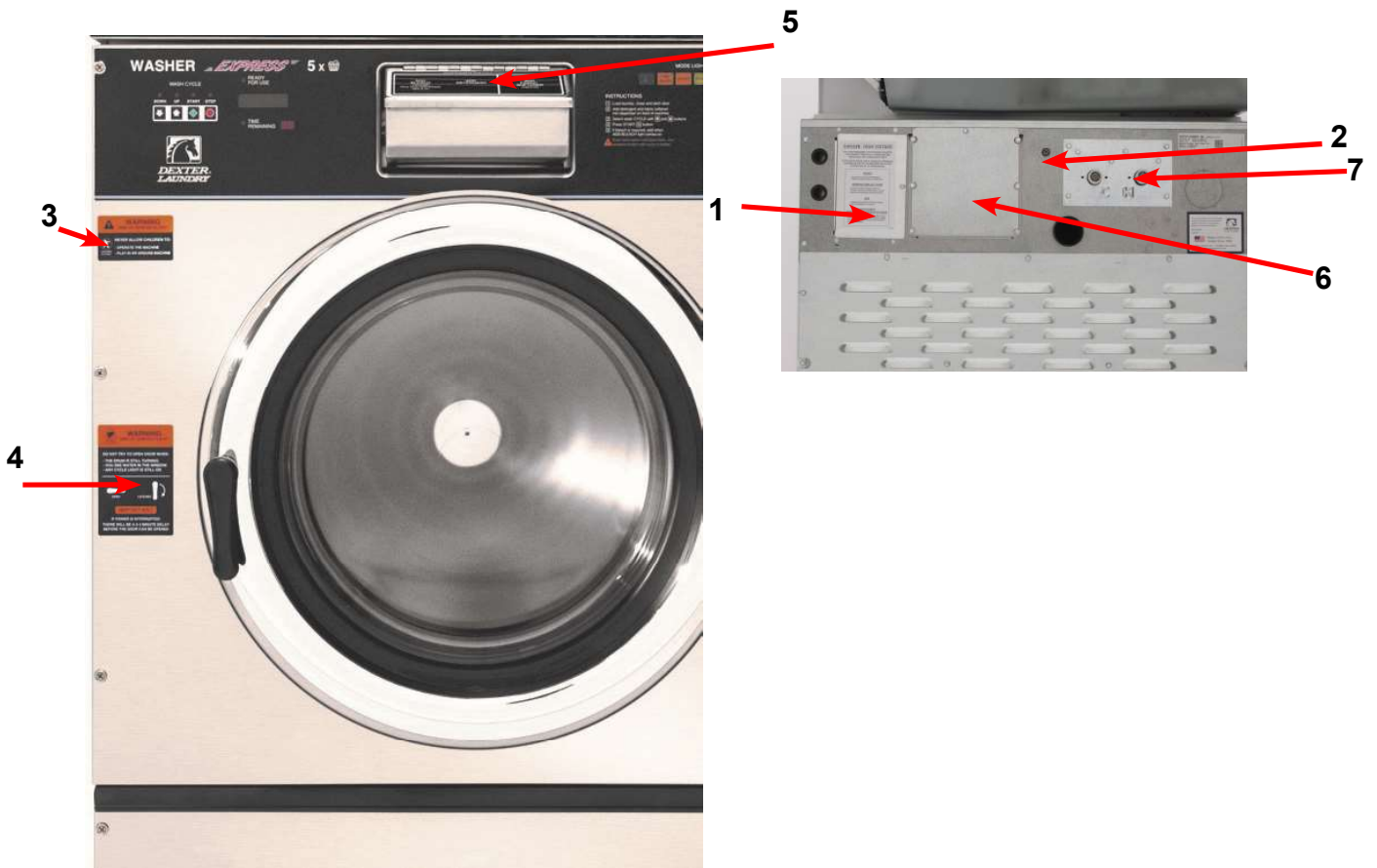

Wiring Schematic for 60hz opl Washer

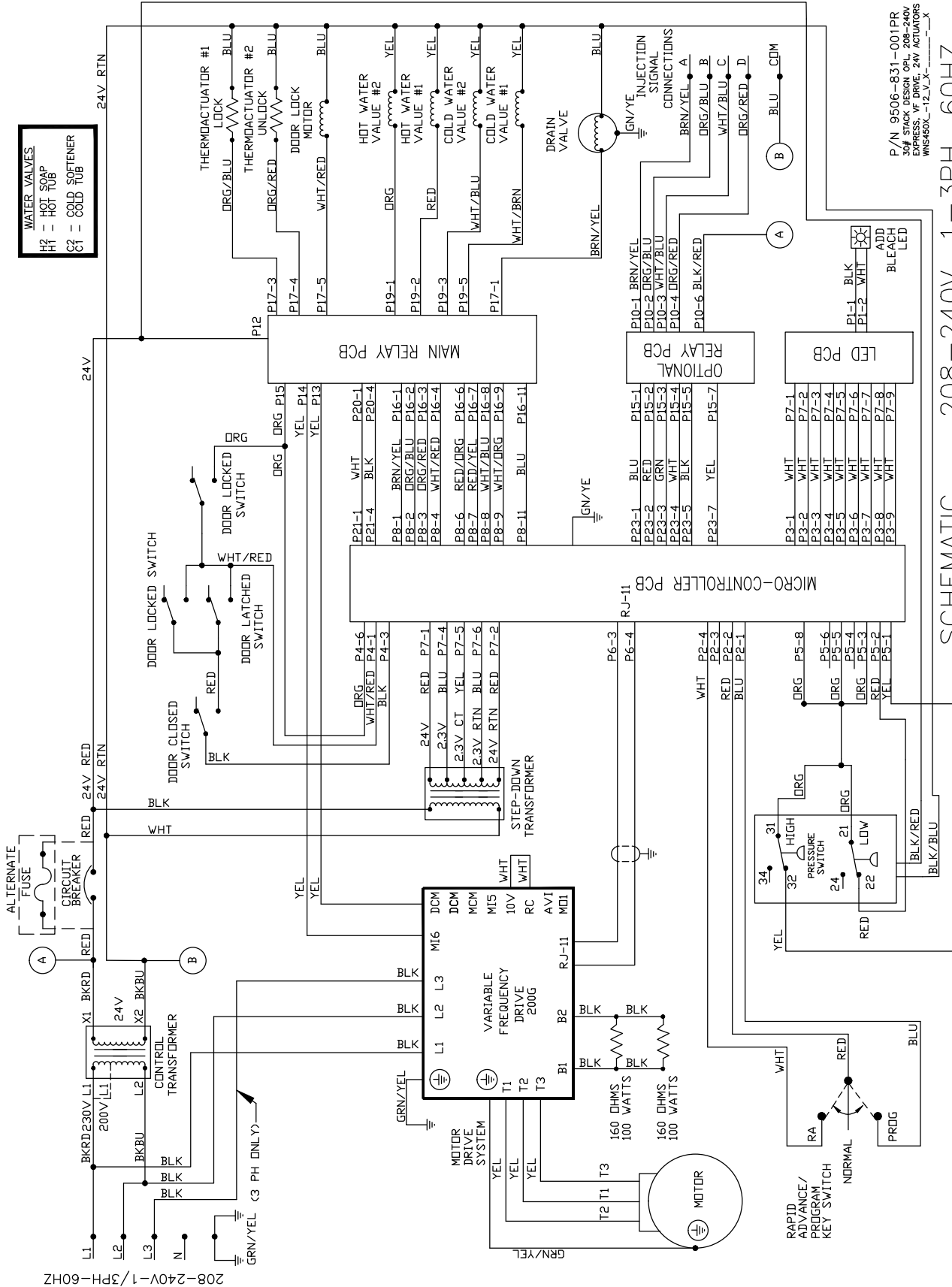

P/N 9506-831-001PR
 30# STACK DESIGN OPL 208-240V
 EXPRESS: VF DRIVE, 24V ACTUATORS
 WNS45DX_-12_V_X-_-_-X

SCHEMATIC 208-240V, 1-3PH, 60HZ

Wiring Diagram for 60hz opl Washer

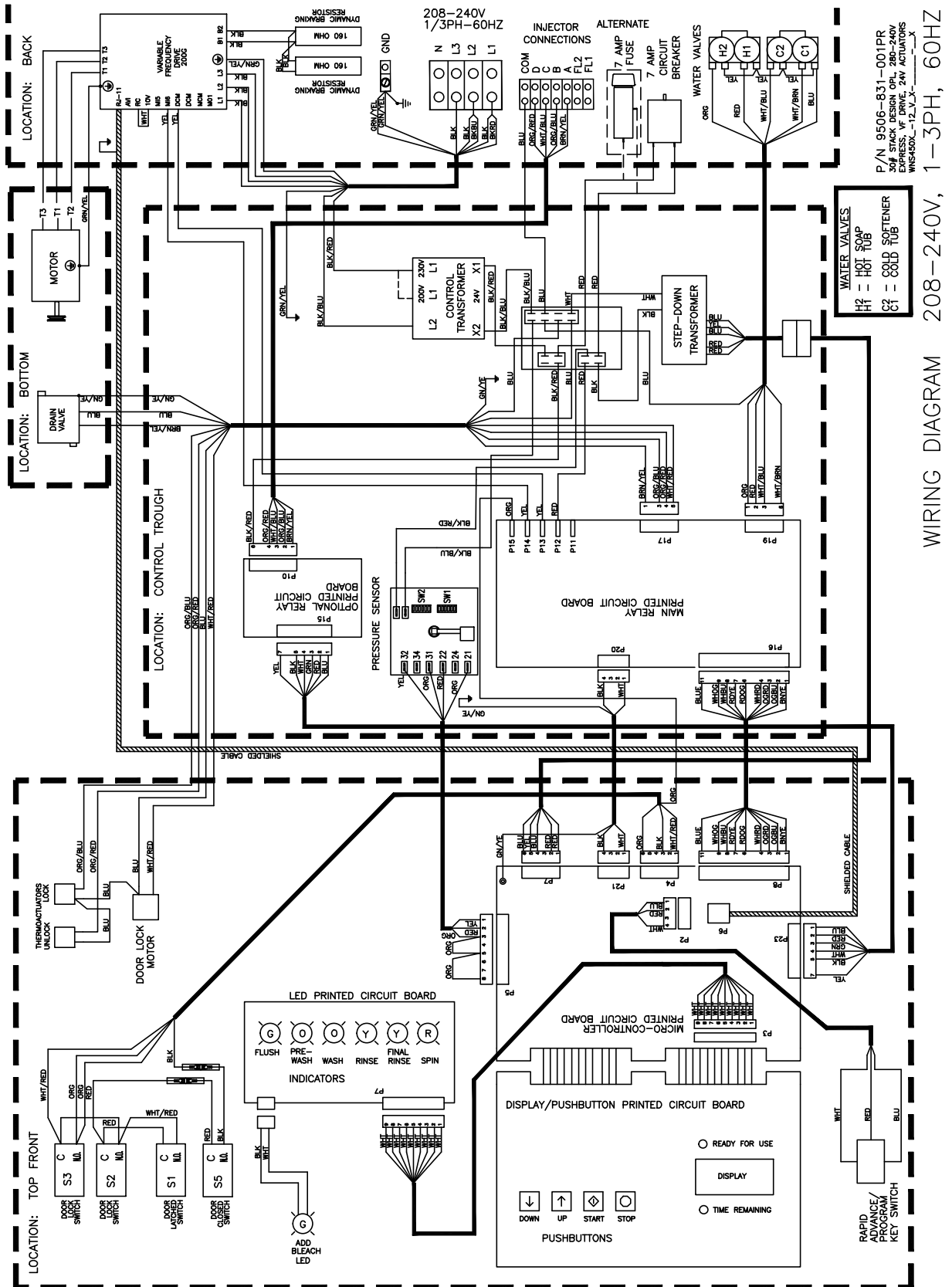

Section: 12

50 Hz Washer

Models

Parts in this section used only in these models. All other parts are same as standard 60 Hz pages.

Wiring Schematic for 50hz Washer -39

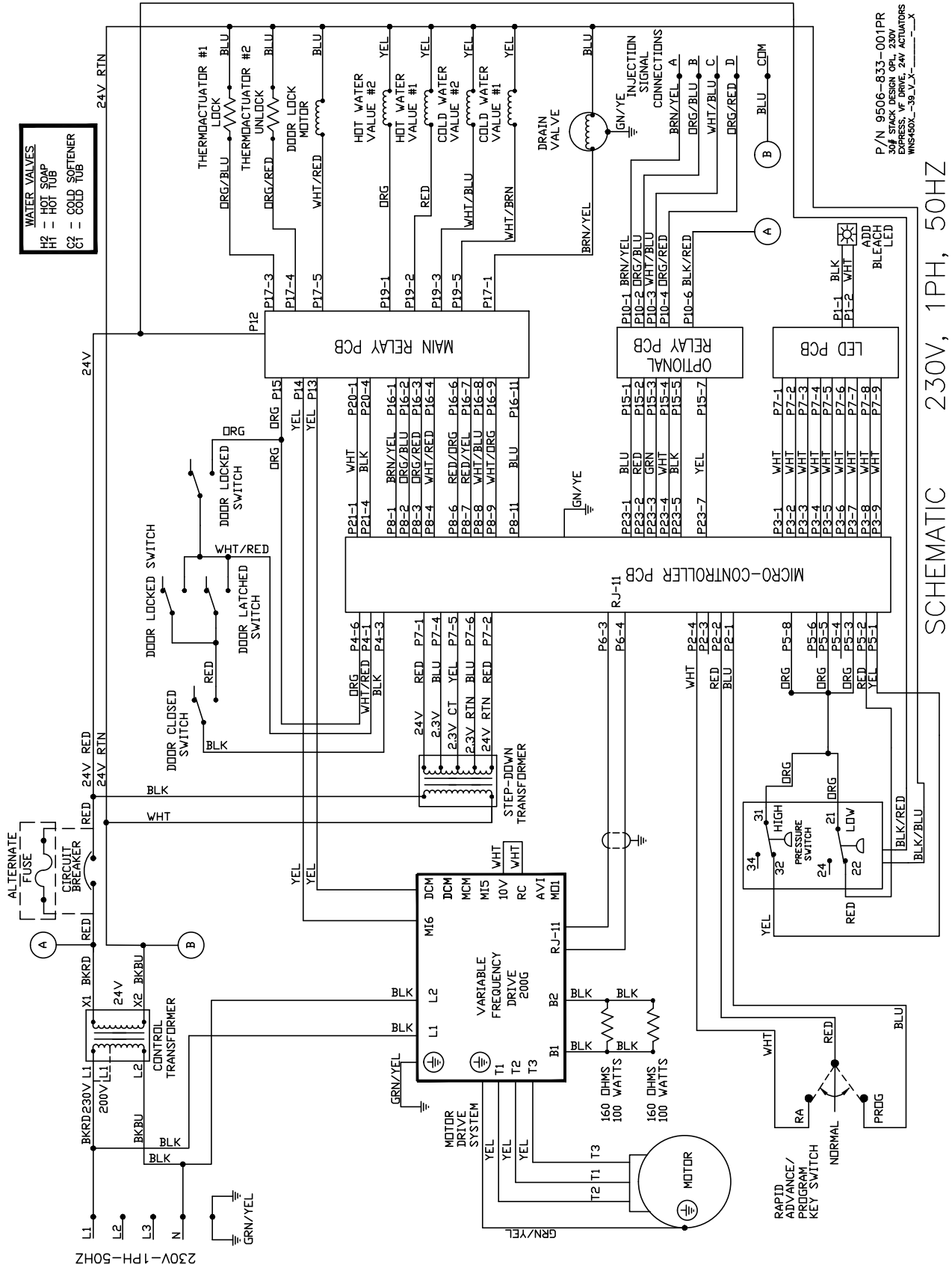

P/N 9506-833-001PR
 30# STACK DESIGN OPL, 230V
 EXPRESS, VF DRIVE, 24V ACTUATORS
 WMS4602L_38_V_X_---

Wiring Diagram for 50hz Washer -39

