



## Section 6:

Parts data for the following models:

	Model	HZ	Phase	Voltage	Heat Option	G's
9999-662-001	WN0600XA-12EN2X-SSKCS-USX	60	1 - 3ph	208 - 240v		100
9999-662-003	WN0600EA-13EN2X-SSKCS-USX	60	3ph	208 - 240v	Heated Electric	100
9999-665-001	WN0900XA-12EN2X-SSKCS-USX	60	1 - 3ph	208 - 240v		100
9999-665-003	WN0900EA-13EN2X-SSKCS-USX	60	3ph	208 - 240v	Heated Electric	100
9999-669-001	WN1200XA-12EN2X-SSKCS-USX	60	1 - 3ph	208 - 240v		100
9999-669-003	WN1200EA-13EN2X-SSKCS-USX	60	3ph	208 - 240v	Heated Electric	100
	Model	HZ	Phase	Voltage	Heat Option	G's
9999-662-002	WN0600XA-39XN2X-SSKCS-VRX	50	1ph	230 - 240v		100
9999-662-004	WN0600EA-68XN2X-SSKCS-VRX	50	3ph	400v	Heated Electric	100
9999-662-005	WN0600FA-59CN2X-SSKCS-VRX	50	1ph	230		100
9999-665-002	WN0900XA-39XN2X-SSKCS-VRX	50	1ph	230 - 240v		100
9999-665-004	WN0900EA-68XN2X-SSKCS-VRX	50	3ph	400v	Heated Electric	100
9999-669-002	WN1200XA-39XN2X-SSKCS-VRX	50	1ph	230 - 240v		100
9999-669-004	WN1200EA-68XN2X-SSKCS-VRX	50	3ph	400v	Heated Electric	100

## Washer Accessories

Key	Description	T-600	T-900	T-1200	QTY
*	Hose, Water Supply 5/8" I.D. x 48"	9990-027-013	9990-027-013	9990-027-013	2
*	Washer, Inlet Hose (furnished)	8641-242-000	8641-242-000		2
*	Strainer, Inlet Hose (furnished)	9565-003-001	9565-003-001		2
	Hose, Water Supply 5/8" I.D. x 48"			9990-027-013	4
	Washer, Inlet Hose (furnished)			8641-242-000	4
	Strainer, Inlet Hose (furnished)			9565-003-001	4
*	Bevel Washer for 5/8" bolt used in installations using angle iron bases	8641-586-002	8641-586-002	8641-586-002	
*	Bevel Washer for 3/4" bolt used in installations using angle iron bases	8641-586-003	8641-586-003	8641-586-003	
*	Sealing compound	8538-151-002	8538-151-002	8538-151-002	
*	Flow Restrictors (in dispenser )	9475-002-002	9475-002-002		2
	Flow Restrictors (in dispenser )			9475-002-003	3
*	Special Tool for adjusting spacing between outer tub front and cylinder front		8545-056-001	8545-056-001	
*	VFD Filter options (3 phase)	9732-231-001	9732-255-001	9732-256-001	
*	VFD Filter options (1 phase)	9732-232-001	9732-230-001	9732-251-001	
*	Puller for pushing cylinder out of bearings must be purchased from local sources.				
*	Clamps to hold tub front to outer tub when installing tub front		Vise Grip #11R	Vise Grip #11R	
*	OPL Bearing & Seal Kit	9732-219-005	9732-219-007	9732-219-007	
*	USB Thumb Drive	9150-045-002	9150-045-002	9150-045-002	
*	Informative	6102-018-235	6102-018-237	6102-018-240	

# Wiring Harness Group

Key	Description	T-600	T-900	T-1200	QTY
*	Wiring Diagram,	9506-759-001	9506-763-001	9506-771-001	1
	Wire Hrnss from Door lock Assy	9627-837-001	9627-891-001	9627-891-001	1
*	Wire Hrnss,Door Lock CPU	9627-891-001	9627-892-001	9627-892-001	1
*	Wire Hrnss Power Terminal Block	9627-747-003	9627-747-003	9627-747-002	1
*	Wire Hrnss,to Drn,Thermo,DorSol	9627-893-001		9627-796-002	1
*	Wire Hrnss,Trough	9627-697-001	9627-697-001	9627-697-001	1
*	Wire Hrnss CPU to I/O board	9627-706-001	9627-706-001	9627-706-001	1
*	Wire Hrnss Control VFD	9627-811-002	9627-811-001	9627-811-001	1
*	Wire Hrnss CPU to Display	9627-705-001	9627-705-001	9627-705-001	1
*	Wire Hrnss Control-VF-Shield	9627-810-001	9627-810-001	9627-810-001	1
*	Wire Hrnss Pressure Switch	9627-704-001	9627-704-001	9627-704-001	1
*	Wire Hrnss Membrane Switch	9627-700-001	9627-700-001	9627-700-001	1
*	Wire Hrnss 120VAC	9627-893-001	9627-893-001	9627-894-001	1
*	Wiring Assembly Diode	8220-001-442	8220-001-442	8220-001-442	1
*	Wiring Assembly Red 8"			8220-108-009	1
*	Wiring Assembly Wht/Brn 8"			8220-108-007	1
*	Wire Jumper White/Red	8220-090-001	8220-090-001	8220-090-001	1
*	Wire Yellow Jumper (Violet)	8220-090-010	8220-090-010	8220-090-010	1
*	Wiring Assembly Red 28"	8220-062-025	8220-062-025	8220-062-025	1
*	Wiring Assembly Dor Csl Red 23"		8220-063-028	8220-063-028	2
*	Wire Assy Jumper BLK.(brk resit)	8220-117-002	8220-117-002	8220-117-002	2
*	Wiring Assembly	9631-381-018	9631-381-018	9631-381-018	1
*	Wiring Assembly	8220-090-009	8220-090-009	8220-090-009	1
*	Wiring Assembly	8220-001-231	8220-001-231	8220-001-231	1
*	Wire Red 20"		8220-001-282	8220-001-282	1
	Ribbon Cables	9500-001-001	9500-001-001	9500-001-001	2
*	Wire Yellow Jumper (water valve)	8220-123-001	8220-123-001	8220-119-002	1
	Wiring Assembly Dor Csl blk 23"		8220-063-029		2
	Wire-White 11 1/2"	8220-001-296	8220-001-296	8220-001-296	2
	Wire-White 3"	8220-057-036	8220-057-036	8220-057-036	1
*	Wiring Assembly - White/Red	8220-001-371			
	Wiring Assembly - Red	8220-001-372			
	Wiring Assembly - Red 17"	8220-063-025			

# Labels and Diagrams All 30 cycle Models

Key	Description	T-600	T-900	T-1200	QTY
*	Transient Voltage Surge Suppressor Infomational	8507-330-001	8507-330-001	8507-330-001	
*	Inst. Spin Direction	8507-274-001	8507-275-001	8507-275-001	1
*	Inst. Chemical Hose	8507-268-001	8507-268-001	8507-268-001	1
*	Injector Connections Label	8502-647-002	8502-647-002	8502-647-002	1
*	Wiring Schematic/Diagram	9506-759-001	9506-763-001	9506-771-001	1
*	Label for Electrical Connections	8502-649-001	8502-649-001	8502-649-001	1
*	Label High Voltage Warning	8502-614-004	8502-614-004	8502-614-004	1
*	Label Fusing & Installation	8502-619-004	8502-619-003	8502-619-003	1
*	Label Quality	8511-001-002	8511-001-002	8511-001-002	1
1	Label Warning Risk of Injury (Black)	8507-759-001	8507-759-001	8507-759-001	1
2	Label Warning Door Opening (Black)	8502-757-001	8502-757-001	8502-757-001	1
*	Booklet Owners	8514-241-001	8514-244-001	8514-246-001	1
3	Label Top Dispenser (Black)			8502-745-001	1
*	Injector Label Assembly	8502-666-001	8502-666-001	8502-666-001	1
*	Dispenser Instructions	8502-650-001	8502-650-001		1
*	Installer Installation Instruction	8502-653-001	8502-653-001	8502-653-001	1
*	Inst. Control Transformer	8507-449-001	8507-449-001	8507-449-001	1
*	Inst. Connection Transformer	8507-230-001	8507-230-001	8507-230-001	1
*	Inst. Washer Install	8507-448-001	8507-448-001	8507-448-001	1



**Door Label**



**Risk of Injury Label**



**Top Dispenser Label T-1200**

# Control Panel Part # by Model

Key	Description	T-600	T-900	T-1200	QTY
1	Panel Control Assembly(panel only)	9989-463-001	9989-456-001	9989-456-001	1
*	Screw, Hxwshrhnduct #10Bx 1/2" Mtg Control Panel	9545-008-026	9545-008-026	9545-008-026	4
*	Post Locator Top	9467-024-001	9467-024-001	9467-024-001	2
*	Nut Hexkeps #6-32	8640-411-003	8640-411-003	8640-411-003	2
*	Locator Panel	9355-001-001	9355-001-001	9355-001-001	2
*	Screw FillHDCR 10Bx1/2" Guide	9545-008-023	9545-008-023	9545-008-023	2
*	Plate-Latch Top	9452-625-001	9452-625-001	9452-625-001	2
*	8-32 Nut for Plate-Latch&Membrane	8640-412-005	8640-412-005	8640-412-005	7
*	Nut Hexelasticstop #4-40	8640-424-002			2
2	Membran Switch assy (Black)	9801-061-002	9801-061-002	9801-061-002	
*	Plate Membrane switch Assy	9452-637-001	9452-637-001	9452-637-001	1
3	PCB Display	9799-001-001	9799-001-001	9799-001-001	1
*	Nut 8-32 for display	8640-412-005	8640-412-005	8640-412-005	4
4	Lock-Run/Program Switch w harness & Key	8650-028-001	8650-028-001	8650-028-001	1
5	Harness, CPU to Display	9627-705-001	9627-705-001	9627-705-001	1
	Harness, Membrane Switch	9627-700-001	9627-700-001	9627-700-001	1
6	Nameplate,Control Panel (one piece) (Black)	9412-222-001	9412-226-001	9412-190-001	1
*	Hex Nuts (mounting Door Lock assy. to control panel)	8640-412-005	8640-412-005	8640-412-005	4
7	Catch, Top Panel	9086-017-001	9086-017-001	9086-017-001	2

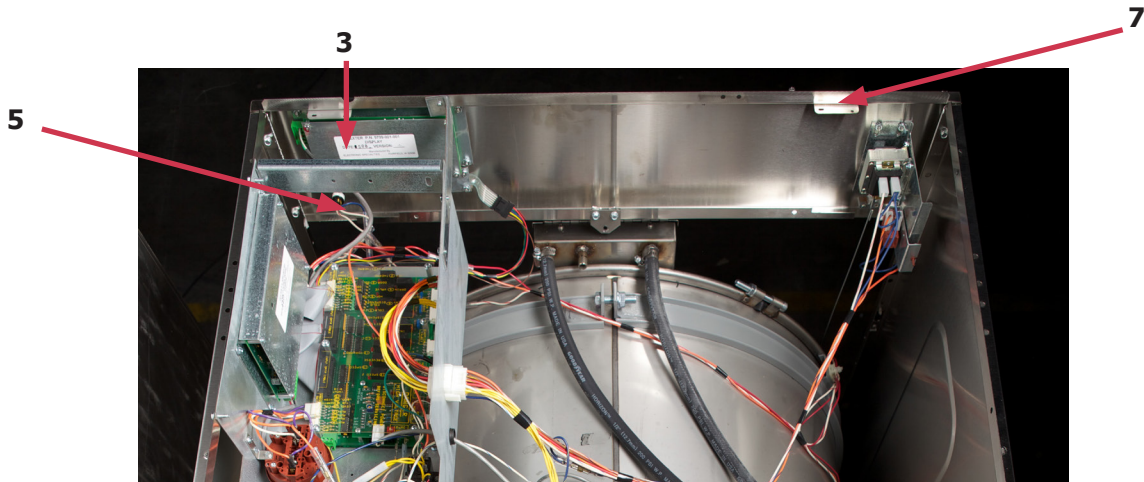

# Cabinet and Front Panel Group

Key	Description	T-600	T-900	T-1200	QTY
1	Panel, Side (Left or Right) - stainless	9454-815-001			2
1	Panel, Side (Left or Right) - stainless		9454-839-001	9454-814-001	4
*	Screw, (Side Panel to Base)	9545-018-013	9545-018-013	9545-018-013	8
*	Nut, Hex 1/4-20 UNC	8640-414-006	8640-414-006	8640-414-006	8
*	Strap Assembly Side Panel		9966-012-001	9966-012-002	4
*	Nuts, strap to side panel & brace		8640-414-006	8640-414-006	8
*	Bracket brace, Side Panel under front panel	9029-263-001	9046-085-001	9046-085-001	1
*	Nut, Hex	8640-413-002			2
*	Screw	9545-008-026	9545-008-026		1
*	Foam Pad damper	0904-904-001			2
2	Panel, Control (Mounts Nameplate)	9989-463-001	9989-456-001	9989-456-001	1
*	Screw, Control Panel to Side Panel	9545-008-026	9545-008-026	9545-008-026	4
3	Nameplate Decal, Control Panel Black	9412-222-001	9412-226-001	9412-229-001	1
4	Membrane Switch Black	9801-061-002	9801-061-002	9801-061-002	1
*	Screw, Hex- Control to Front Panel	9545-008-024	9545-008-024	9545-008-024	2
*	Nut, Spring- Control to Front Panel 10/32	8640-399-008	8640-399-005	8640-399-005	2
5	Panel Assy, Front	9454-895-002	9454-840-002	9454-811-002	1
*	Screw Front Panel Mtg.	9545-008-023	9545-008-024	9545-008-024	2
*	Flat Washer #10	8641-585-001	8641-585-001	8641-585-001	2
*	Spring Nut	8640-399-008	8640-399-008	8640-399-008	5
*	Band, Edge Protector Trim	9578-092-005	9578-092-002	9578-092-002	1
6	Bumper Loading Door	9051-055-001	9051-055-001	9051-055-001	1
*	Nut, Bumper Hold	8640-414-003	8640-414-003	8640-414-003	1
7	Screw, Flat Head- Front to Sides	9545-008-014	9545-008-014	9545-008-014	2
8	Washer, Finish (Front Panel)	8641-585-001	8641-585-001	8641-585-001	2
*	Nut, Spring-To Front Panel	8640-399-008	8640-399-008	8640-399-008	2
9	Label, Door Opening Black	8502-757-001	8502-757-001	8502-757-001	1
10	Label, Warning, Risk of Injury Black	8507-759-001	8507-759-001	8507-759-001	1
11	Panel Top	9454-735-001	9454-736-001		1
11	Panel Top Front			9454-761-001	1
11	Panel Top Rear			9454-762-001	1
12	Lock, Top (w/Key)	8650-012-003			1
12	Lock, Top (w/Key)		8650-012-003	8650-012-003	2
*	Cam, Top Lock each	9095-049-001	9095-049-001	9095-049-001	1
*	Cam Nut 9/32 - 28 Hex each	8640-426-001	8640-426-001	8640-426-001	1
*	Washer Flat 5/16	8641-581-008	8641-581-008	8641-581-008	1
13	Door, Lower Service(w/Handle)	9960-286-002	9960-286-004	9960-286-004	1
14	Handle (bumper guard)	9244-086-002	9244-086-003	9244-086-003	1
*	Rivet	9491-009-003	9491-009-003	9491-009-003	4
15	Screw Mtg., Flat Head	9545-008-014	9545-008-014	9545-008-014	2
*	Nut, Spring	8640-399-008	8640-399-008	8640-399-008	2
16	Washer, Finish (Front Panel)	8641-585-001	8641-585-001	8641-585-001	2

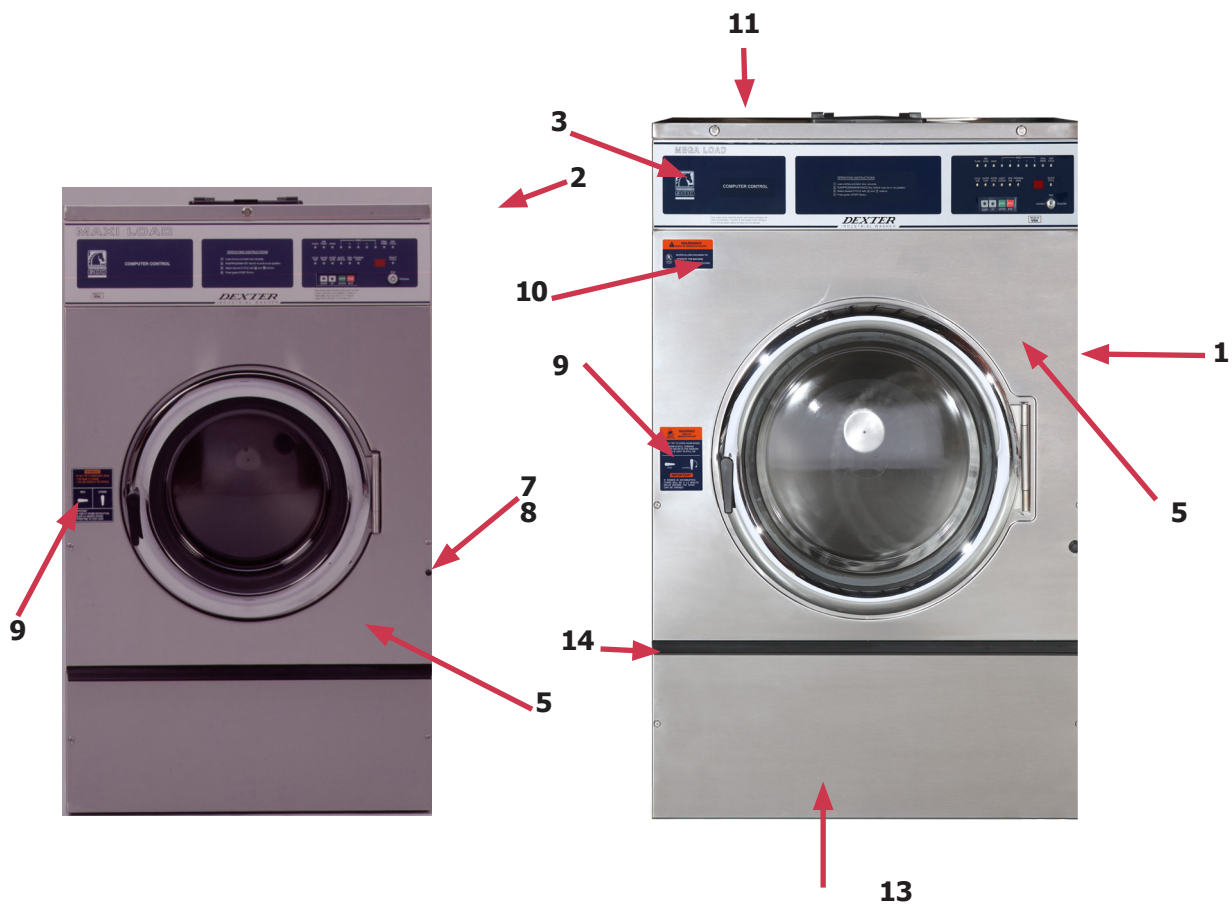

# Cabinet and Front Panel Group Part # by Model

## Front Soap Dish

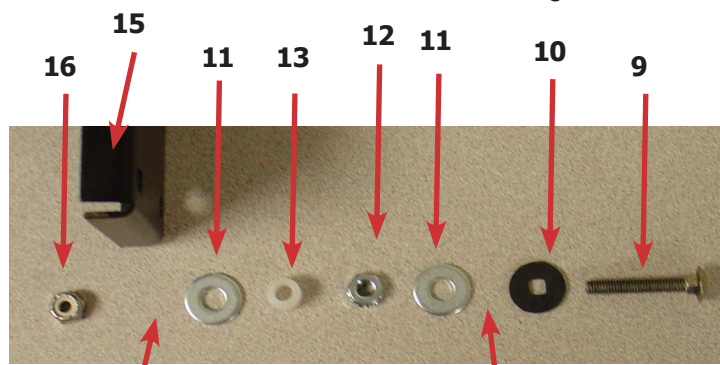
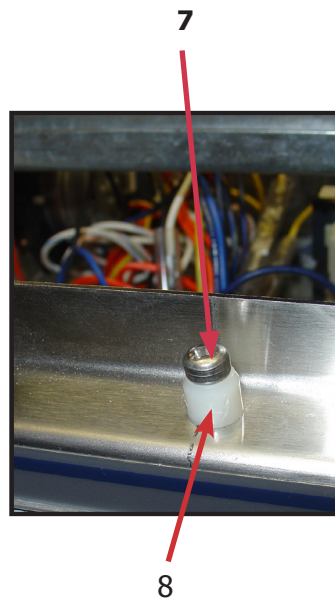
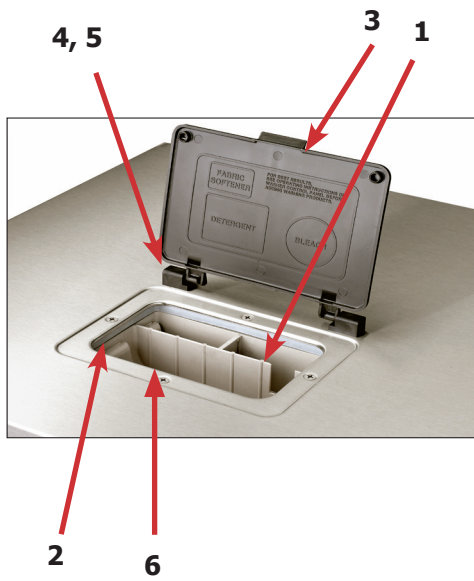

Gasket and Soap Dish Here

Tub Front Here

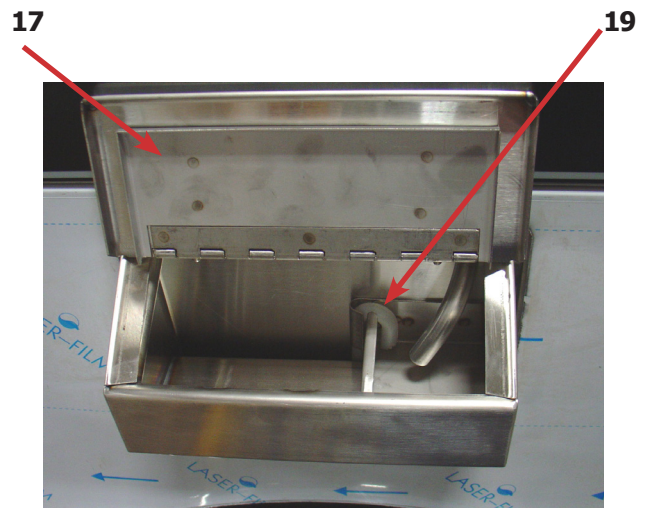
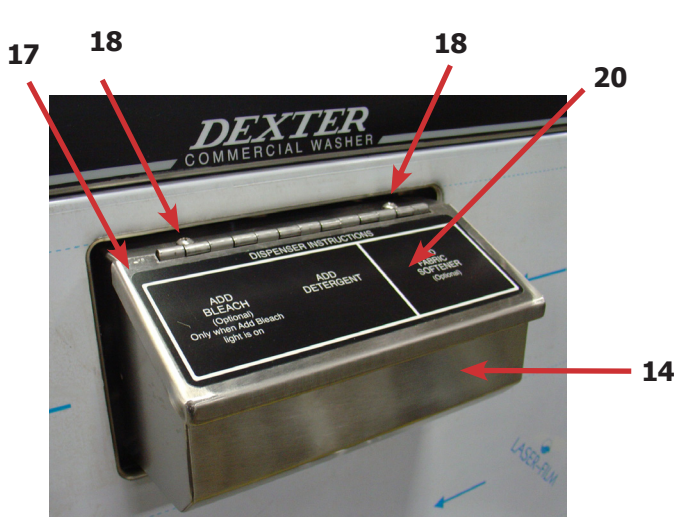



## Top Mount Detergent Dispenser

Key	Description	T-600	T-900	T-1200	QTY
1	Dispenser Soap	9122-005-004	9122-005-004		1
2	Gasket Dispenser	9206-416-001	9206-416-001		1
*	Hose, Dispenser to tub	9242-450-001	9242-450-001		1
*	Clamp	8654-117-008	8654-117-008		2
*	Nut, Spring ss	8640-399-007	8640-399-007		4
*	Flow restrictors	9475-002-002	9475-002-002		2
*	Flow restrictors Optional (Smaller)	9475-002-003	9475-002-003		2
3	Door, Dispenser	9108-095-005	9108-095-005		1
4	Pin, Plain	9451-191-001	9451-191-001		2
*	Post, Door Mounting	9467-025-001	9467-025-001		2
6	Screw- 8B x 1/2	9545-045-002	9545-045-002		4
	Screw, SS Dispenser, 10B x 1	9545-008-012	9545-008-012		4
*	Washer Flat 5/16	8641-581-008	8641-581-008	8641-581-008	1
7	Screw, Locator	9545-008-023	9545-008-023	9545-008-023	1
8	Plastic Sleeve, Locator	9355-001-001	9355-001-001	9355-001-001	1
*	Catch, Top Panel	9086-017-001	9086-017-001	9086-017-001	2
	Lock, Top (w/Key)	8650-012-003			1
*	Lock, Top (w/Key)		8650-012-003	8650-012-003	2

## Front Mount Detergent Dispenser

Key	Description	T-600	T-900	T-1200	QTY
9	Bolt,#10-32 x 1 1/4"SS			9545-012-026	6
10	Special Washer, Rubber			8641-242-000	4
*	Tub Front			9178-048-002	1
11	Washer-Flat, 1/4			8641-581-018	4
12	Nut, #10-32UNF			8640-413-002	6
13	Spacer Plastic #10x1/2			9538-157-019	6
14	Soap Dispenser (no lid)			9807-087-001	1
*	Det. Dispenser Mtg Gasket to Tub frnt			9206-425-001	1
15	Bracket Soap box mounting			9029-122-002	1
16	Nut Hex Elasticstop #10-32 SS mtg dispenser			8640-413-006	6
17	Lid Assembly dispenser			9987-104-001	1
18	Lid screws #10-32x1/2 SS			9545-012-017	2
19	Softner siphon tube (plastic)			9574-252-002	1
*	Flow restrictors			9475-002-003	AR
20	Washer Dispenser Label Black			8502-756-001	1
*	Kit-Soap Dish, Replacement (Large Door)			9732-290-001	

## Rear View Access Part # by Model T-600

Key	Description	T-600	QTY
1	Drive Motor, 3 Phase (Inverter duty)	9732-127-012	1
2	Pulley, Motor	9453-170-003	1
*	Set Screw, Sq.Hd(motor pulley)	9545-028-015	2
3	Rod, Motor Mtg	9497-222-004	1
*	Screw (end of motor rod)	9545-029-005	1
*	Lockwasher (end of motor rod)	8641-582-014	1
*	Collar, Shaft (w/set screws) removed starting #530726	9076-052-002	2
4	Motor Bushing (Rubber)	9053-082-001	2
5	Clamp-Worm, 316SS, 1.5"	8654-117-019	2
6	Strap Bracket, Motor Tension	9029-206-001	1
*	Nut, Strap to Motor 10/32 UNF	8640-413-002	1
*	Washer #10	8641-581-006	1
7	Spring, Belt Tension	9534-319-002	1
8	Pulley, Driven	9453-168-003	1
*	Tolerance Ring driven pulley	9487-234-003	1
9	Screw 5/8-11x1/2" Driven pulley	9545-060-001	1
10	Lockwasher 5/8"	8641-582-018	1
11	Washer, Flat 5/8x2 1/4"	8641-581-032	1
12	Drive Belt	9040-076-005	2
13	Hose, Overflow Vent Top	9242-463-003	1
*	Clamp, Hose Vent	8654-117-008	1
14	Hose, Overflow to drain	9242-449-002	1
*	Clamp, Hose overflow to drain	8654-117-018	2

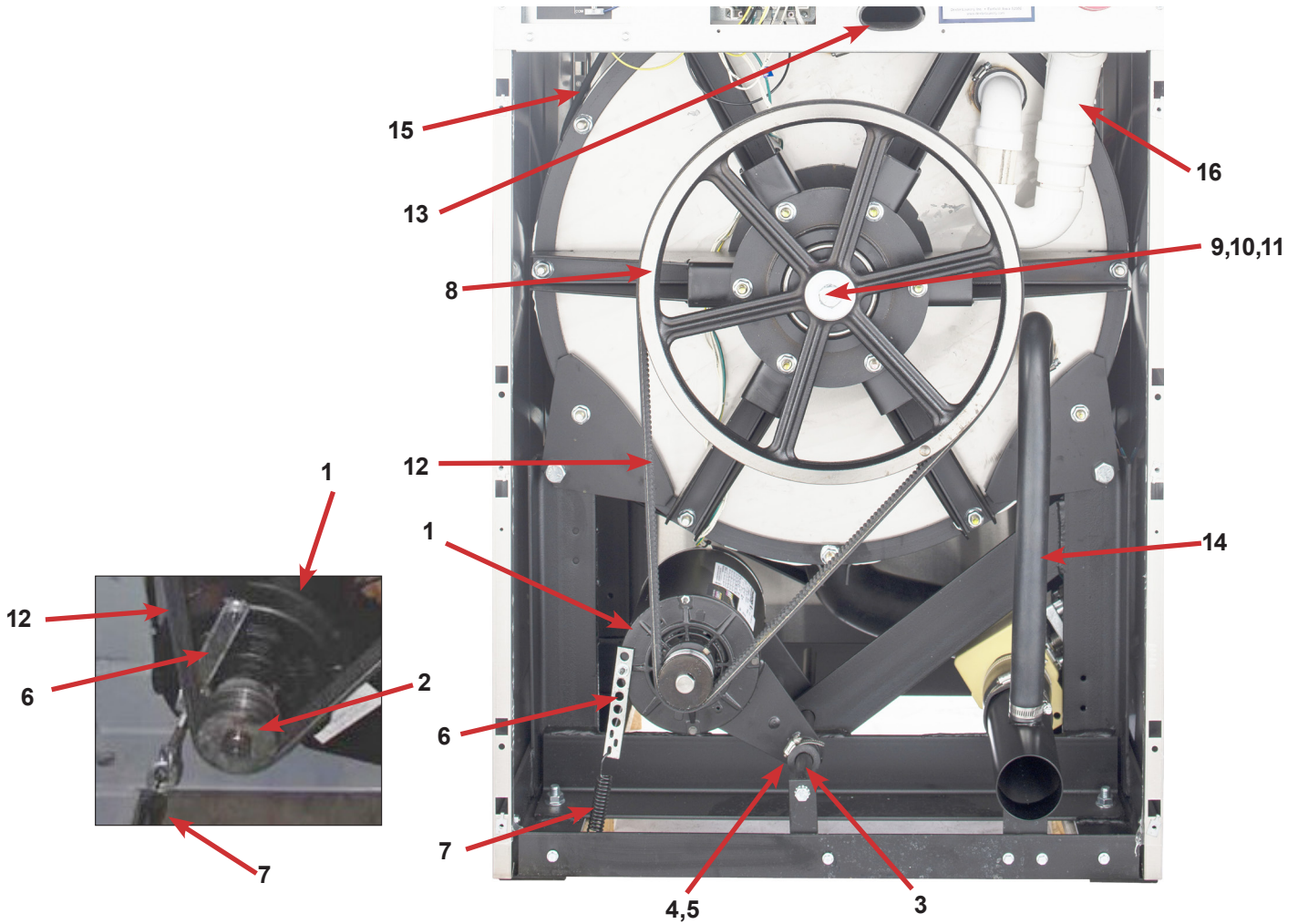

Key	Description	T-600	QTY
15	Hose, Pressure Switch	9242-175-002	1
*	Clamp, Pressure Switch Hose	8654-117-015	1
	Vacuum Breaker Mtg Bracket	9029-077-001	1
*	Vacuum Breaker ALL	9610-001-001	1
*	Clamp, Hose to Vacuum Breaker	8654-117-014	1
*	Hose, Vacuum Breaker to tub	9242-461-001	1
*	Hose, Vacuum Breaker to Injector	9242-461-001	1
*	Clamps	8654-117-014	1
16	Injector Assembly, Soap	9883-009-001	1
*	Hose, Injector to Tub Back	9242-462-001	1
*	Clamps	8654-117-014	1
*	Panel Assy., Back	9989-562-001	1
*	Screw Panel Mtg.#10x1/2"	9545-008-026	10
*	Nut, Spring	8640-399-004	10
*	Screw, To Base-1/4x3/4	9545-030-002	1

## Rear View Access Part # by Model

Key	Description	T-900	T-1200	QTY
1	Drive Motor, 3 Ph.	9376-308-001	9376-329-001	1
2	Rod, Motor Mtg	9497-222-004	9497-222-004	1
3	New Motor bushing support	9053-082-001	9053-082-001	2
4	Clamp for motor bushing	8654-117-019	8654-117-019	2
5	Pulley, Motor	9453-175-002	9453-175-002	1
*	Split TaperBushing (motor pulley)	9053-077-001	9053-077-001	2
*	Screw taper bushing 1/4-20x1	9545-018-024	9545-018-024	3
6	Bolt, Eye (1/4"-20x1/2")	9545-055-001	9545-055-001	1
*	Nut, 1/4 Elastic Stop	8640-414-003	8640-414-003	1
*	Link (open end)	9341-046-001	9341-046-001	1
7	Chain (Spring Tension)	9099-012-003	9099-012-004	1
8	Spring, Belt Tension	9534-151-000	9534-151-000	1
9	Pulley, Driven	9453-176-005	9453-176-005	1
10	Bolt, 3/8"-16 x 2"	9545-029-011	9545-029-011	3
11	Washer, 3/8"	8641-582-003	8641-582-003	3
*	Bushing Taperlock (Driven)	9053-078-002	9053-078-002	1
12	Washer-Flat .675x2-1/2x1/4	8641-581-043	8641-581-043	1
13	Lockwasher-Exttooth, 5/8	8641-582-018	8641-582-018	1
14	Bolt, 5/8-11x1 1/2	9545-060-001	9545-060-001	1
15	Drive Belt	9040-079-002	9040-079-003	1
*	Panel Assy., Back	9989-526-001		1
*	Panel Back Upper		9454-905-001	1
*	Panel Back Lower		9454-904-001	1
*	Screw Panel Mtg.#10Bx1/2"		9545-008-026	9
*	Screw Panel Mtg.#10Bx1/2"	9545-008-026		9
*	Nut, Spring	8640-399-008	8640-399-008	AR
*	Screw, To Base-1/4" x 3/4"	9545-030-002	9545-030-002	3

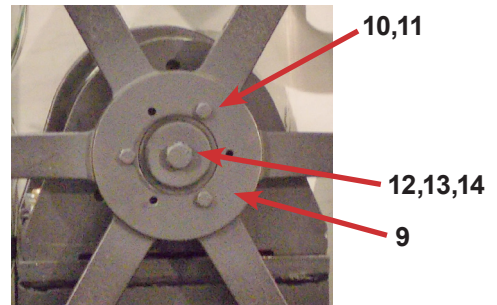
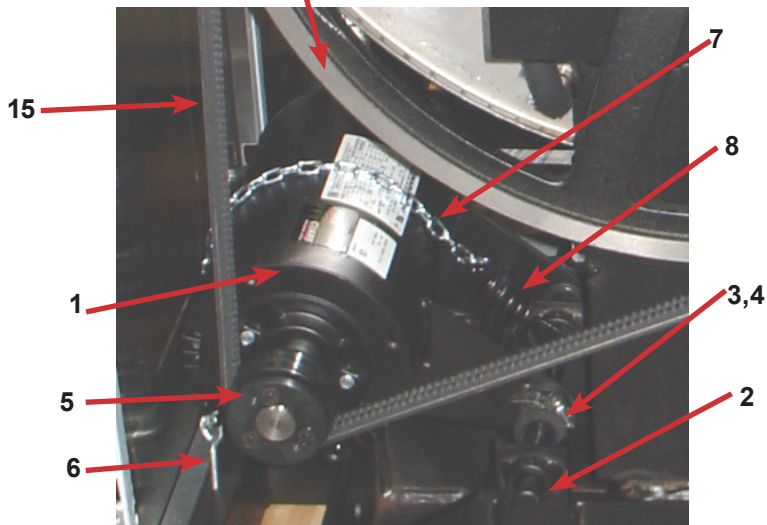
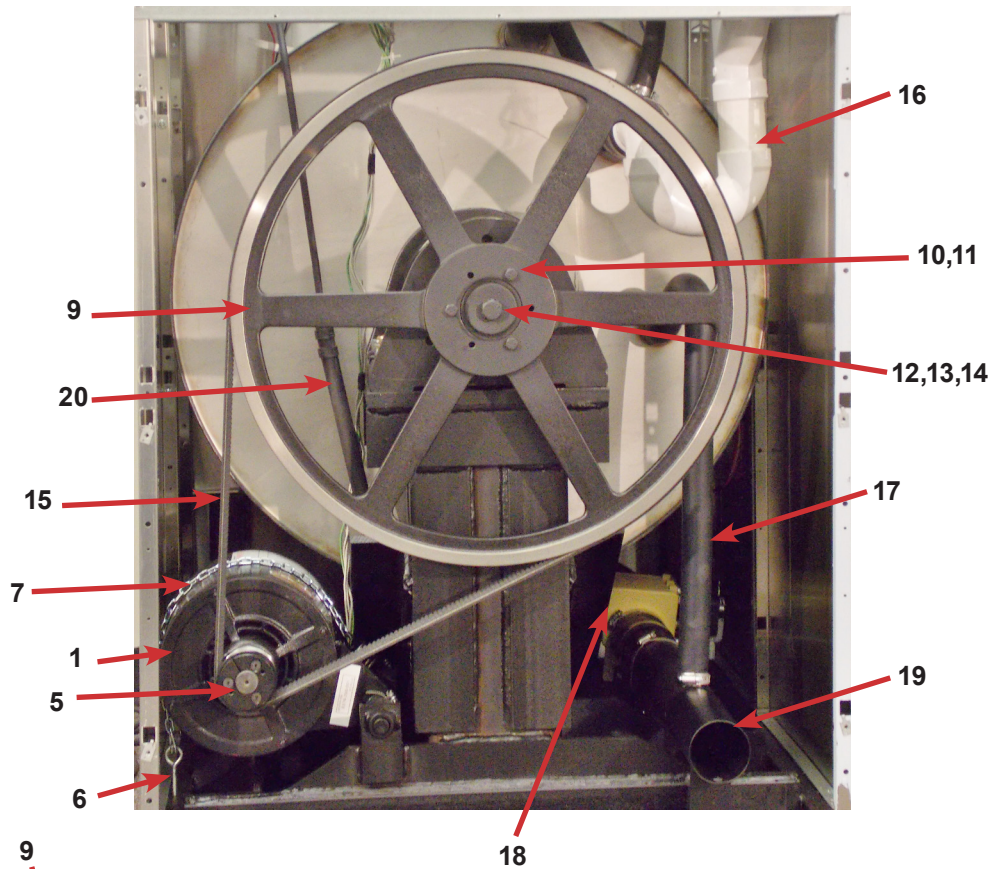

Key	Description	T-900	T-1200	QTY
16	Injection- tube assy	9883-012-001	9883-012-001	1
*	Hose, Injection Tube to Tub	9242-461-001	9242-461-001	1
*	Clamp, Injection Hose	8654-117-014	8654-117-014	2
17	Hose-Overflow	9242-449-003	9242-449-003	1
*	Clamp Hose Over Flow	8654-117-008	8654-117-008	2
18	Drain Valve	9379-202-001	9379-202-001	1
*	Hose, Drain Valve to Tube	9242-457-001	9242-457-001	1
*	Clamp	8654-117-014	8654-117-014	2
19	Drain Tube	9915-120-004	9915-126-002	1
20	Hose-Pressure Switch	9242-175-007	9242-175-004	1

## Rear View Upper Access Part # by Model Continued

Key	Description	T600	T900	T1200	QTY
1	Channel Assembly Rear	9947-026-001	9947-028-001	9947-028-001	1
2	Screw #10Bx1/2	9545-008-026	9545-008-026	9545-008-026	4
*	Nut, Spring	8640-399-008	8640-399-008	8640-399-008	4
3	Plug, 7/8"	9456-041-006	9456-041-006	9456-041-006	1
4	Bushing, 7/8"	9053-067-002	9053-067-002	9053-067-002	1
5	Bracket-Terminal Block Assy	9029-265-001	9029-265-001	9029-265-001	1
6	Screw, 10Bx1/2	9545-008-026	9545-008-026	9545-008-026	4
7	Strip-Terminal marker, Power	9558-025-001	9558-025-001	9558-025-001	1
8	Terminal Block-Power	9897-033-002	9897-033-002	9897-033-002	1
*	Screw-6ABx3/4	9545-031-010	9545-031-010	9545-031-010	2
9	Harness-Power Terminal Block	9627-747-003	9627-747-003	9627-747-003	1
10	Terminal Lug, Solderless	8652-134-001	8652-134-001	8652-134-001	1
*	Lockwasher-Exttooth, #10	8641-582-006	8641-582-006	8641-582-006	1
*	Screw-10-32ttX1x1/2Grn	9545-008-027	9545-008-027	9545-008-027	2
11	Strip-Terminal Marking, Injector	9558-028-001	9558-028-001	9558-028-001	1
12	Terminal Block-Injector	9897-032-002	9897-032-002	9897-032-002	1
*	Screw-4Bx5/8ss	9545-053-002	9545-053-002	9545-053-002	2
13	Harness-Injection	9627-799-001	9627-799-001	9627-799-002	1
14	Label-Warning	8502-639-001	8502-639-001	8502-639-001	1
15	Bushing-Insulated, 3/4"	9053-067-001	9053-067-001	9053-067-001	1
16	Bushing-Insulated, 1"	9053-067-004	9053-067-004	9053-067-004	1
*	Cover, Terminal Block	9074-267-001	9074-267-001	9074-267-001	1
*	Screw #10Bx1/2	9545-008-026	9545-008-026	9545-008-026	1
17	Plate-Drive mounting	9982-383-001	9982-383-001	9982-383-001	1
18	Nut, #10-32UNF, 2B	8460-413-002	8460-413-002	8460-413-002	4
19	VFD Delta "E" drive 208-240 volt	9375-030-012	9375-028-016	9375-028-013	1
*	Key Pad-Display Delta "E" Drive (P/S) only	9150-044-001	9150-044-001	9150-044-001	
20	Nut, #10-32UNF, 2B	8460-413-002	8460-413-002	8460-413-002	4
*	Cable, Data	9806-015-001	9806-015-001	9806-015-003	1
*	Clamp, Cable	8654-125-005	8654-125-005	8654-125-005	1
21	Plate-Water Valves, Mounting	9452-813-001	9452-814-001	9452-814-001	1
22	Nut, #10-32UNF, 2B	8460-413-002	8460-413-002	8460-413-002	4
23	Valve-Water, Duel Coil	9379-183-012	9379-183-012	9379-183-012	2
24	Screw #10Bx1/2	9545-008-026	9545-008-026	9545-008-026	4
25	Water-Valve, Single Coil		9379-194-001	9379-194-001	2
26	Screw-Phillips, 4mx0.7x8mm		9545-064-001	9545-064-001	4
27	Shield, Water Valves	9550-194-001	9550-195-001	9550-195-001	1
28	Clip-Push	9083-121-001			3
28	Clip-Push		9083-121-001	9083-121-001	4
29	Cap-Injector Assy	0935-127-001	0935-127-001	0935-127-001	1
30	Clamp	8654-117-014	8654-117-014	8654-117-014	1
31	Hose-Suds Overflow	9242-463-003	9242-463-004	9242-463-004	1
32	Resistors (160 Ohm)	9483-004-002	9483-004-003	9483-004-003	2
33	Screws #10-32x1/2" (Mounting)	9545-012-008	9545-012-008	9545-012-008	4
34	Jumper Wires	8220-117-002	8220-117-002	8220-117-002	2

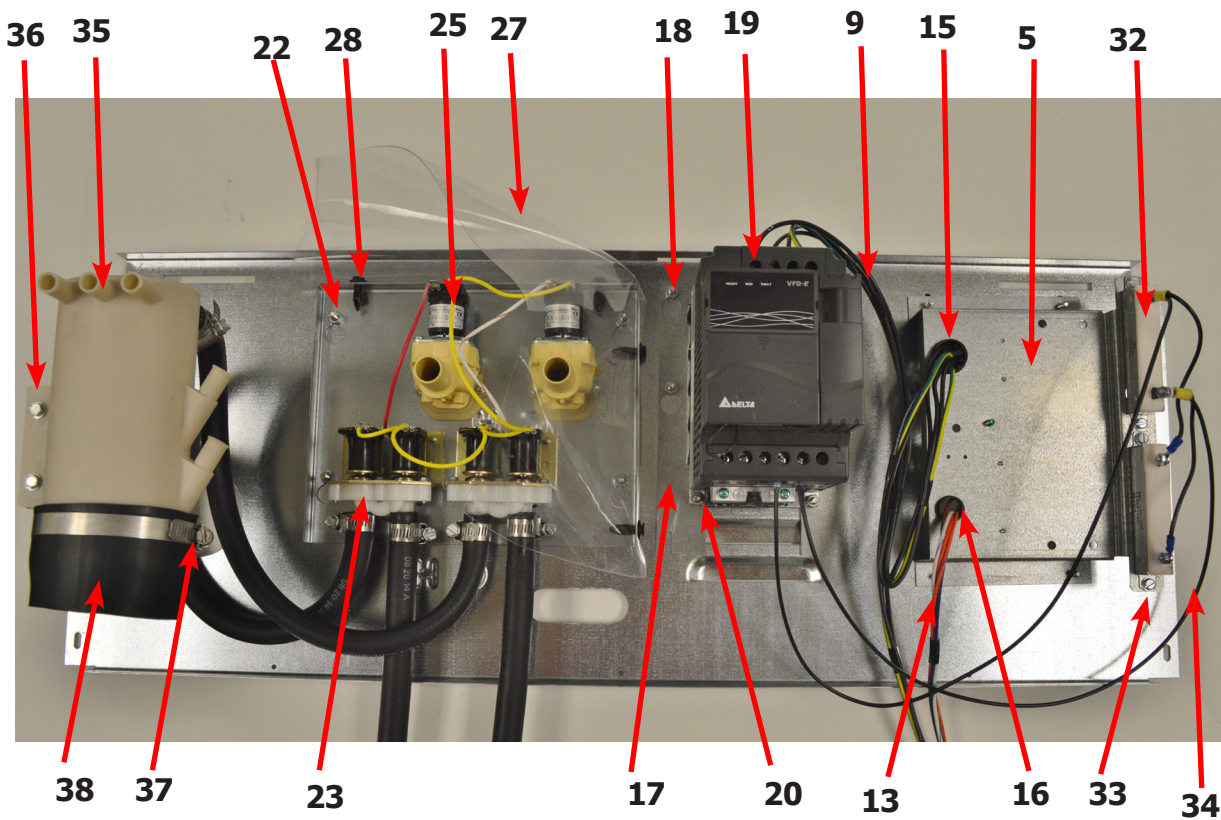
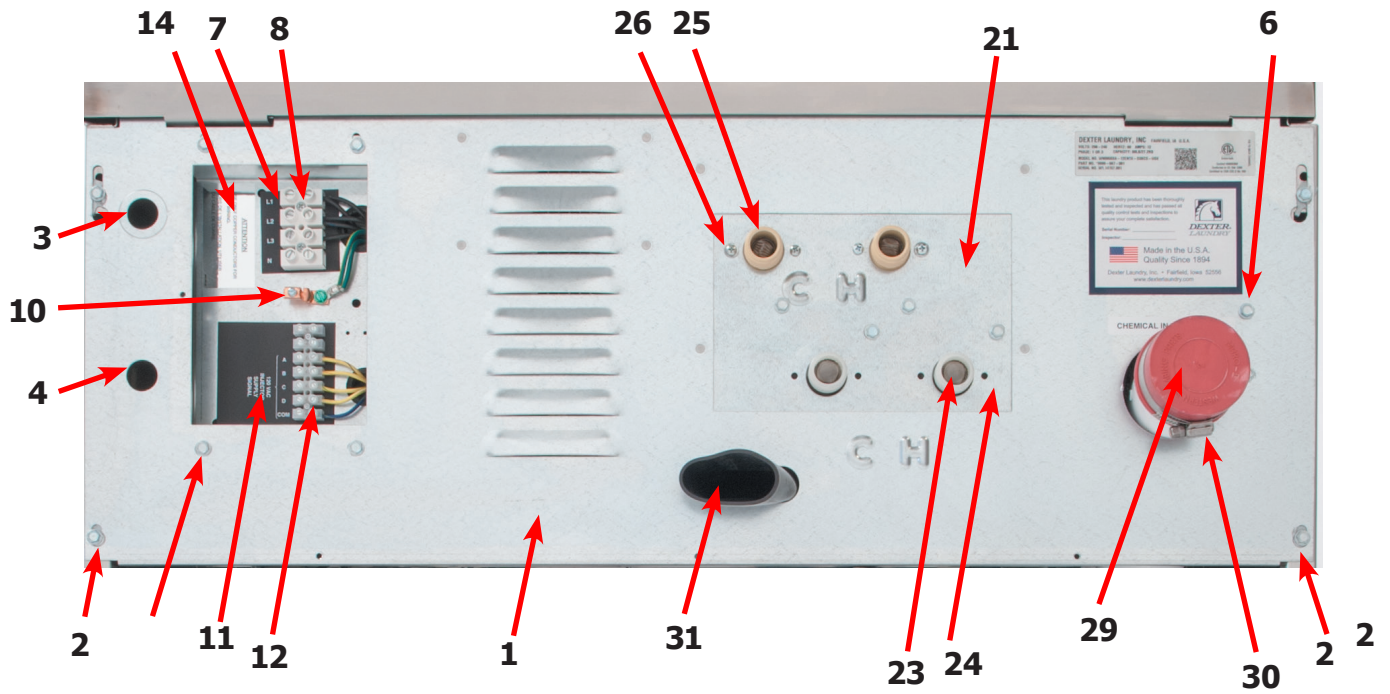

Key	Description	T-600	T-900	T-1200	QTY
35	Vacuum Breaker	9610-001-001	9610-001-001	9610-001-002	1
*	Bracket-Vacume Breaker	9029-077-001	9029-077-001	9029-077-001	1
36	Screw, 10Bx1/2	9545-008-026	9545-008-026	9545-008-026	4
37	Clamp, Vacuum Breaker End	8654-117-014	8654-117-014	8654-117-014	1
38	Hose, Vacuum Breaker to Tub Injection Tube	9242-461-001	9242-461-001	9242-461-001	1

## Cylinder, Seals & Bearings Part # T-600

Key	Description	T-600	QTY
*	Bearing Kit (Includes 2-10)	9732-219-005	
*	Housing, Bearing- Assembly (items #2-#6)	9803-186-001	1
2	Housing, Bearing	9241-180-002	1
3	Bearing, Front (LARGE)	9036-159-005	1
4	Bearing, Rear (SMALL)	9036-159-004	1
5	Spacer, Bearing	9538-167-001	1
6	Ring, Bearing Retainer	9487-238-003	1
7	Tub Back Mating Ring	9487-261-003	1
8	Seal, Primary	9532-140-009	1
9	Seal, Secondary	9532-140-006	1
10	Ring, Seal Mounting	9950-048-001	1
11	Back Assy, Tub	9962-013-001	1
12	Bolt 7/16-14x1 1/2" Tub end of bearing housing	9545-059-003	6
12	Nut 5/8"	8640-425-001	6
13	Support Arm Assy, Bearing Housing	9991-056-002	6
14	Bolt Pulley end of bearing housing (7/16-14x2")	9545-059-002	6
14	Nut, Flange Locking 7/16"	8640-416-005	6
15	Pulley, Driven	9453-168-003	1
*	Ring, Tolerance	9487-234-003	1
16	Washer 5/8"	8641-581-032	1
18	Bolt 5/8-11x1 1/2"	9545-060-001	1
18	Lockwasher 5/8 Ext. tooth	8641-582-018	1
*	Cylinder Assy	9848-113-001	1
*	Tub and Cylinder Assy.	9869-033-001	1
*	Tub Assembly	9930-164-001	1



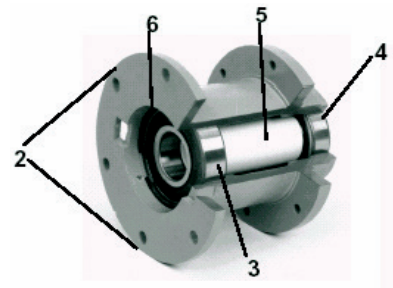
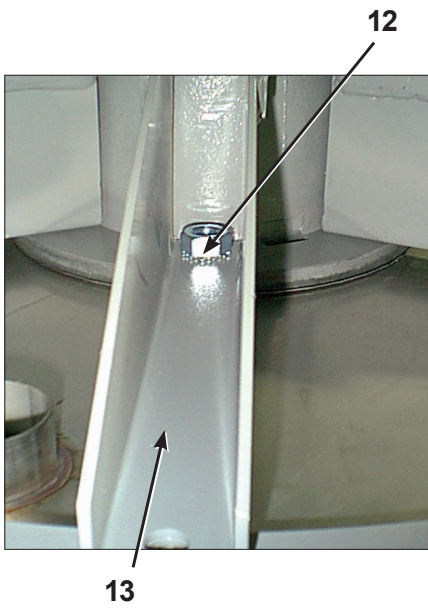
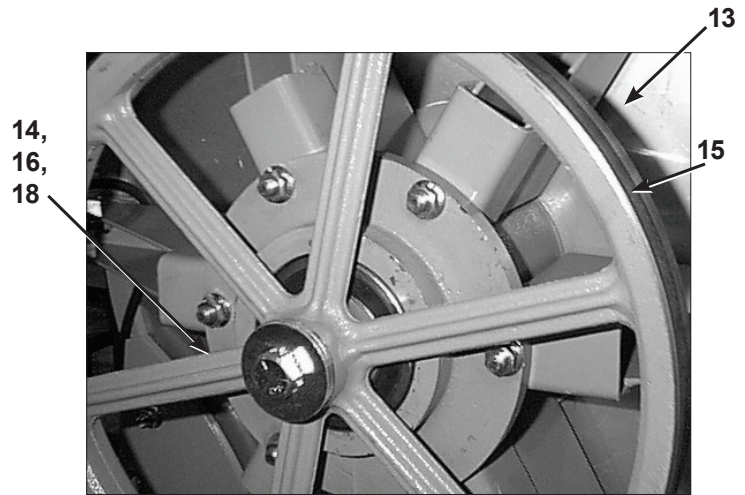
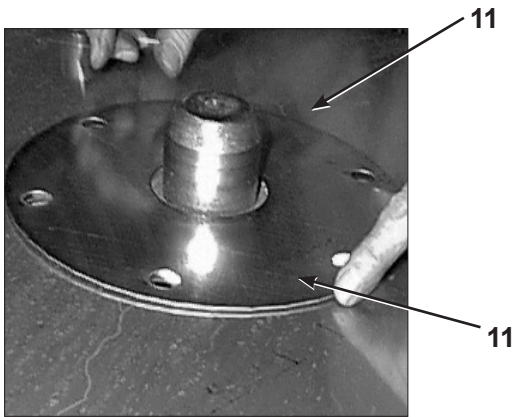
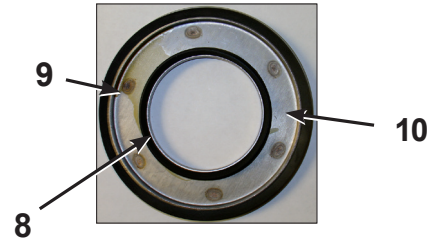
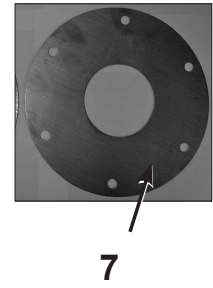
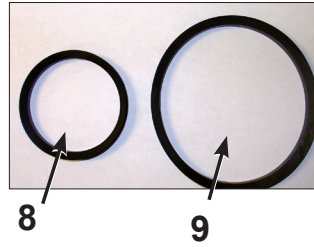
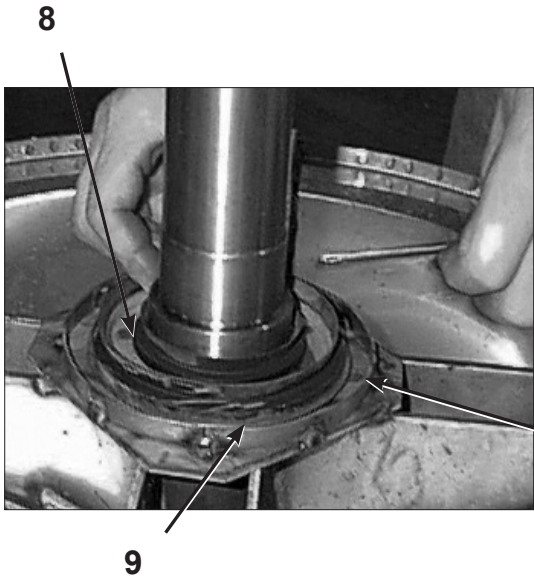

## Cylinder, Seals & Bearings Part # by Model

Key	Description	T-900	T-1200	QTY
1	Housing, Bearing- Assembly (items #2-#6)	9803-187-001	9803-187-001	1
2	Housing, Bearing	9241-181-004	9241-181-004	1
3	Bearing, Front (LARGE)	9036-159-006	9036-159-006	1
4	Bearing, Rear (SMALL)	9036-159-005	9036-159-005	1
5	Spacer, Bearing	9538-170-001	9538-170-001	1
6	Ring, Bearing Retainer	9487-238-004	9487-238-004	1
7	Tub Assembly	9930-157-001	9930-150-001	1
8	Seal, Primary V85A	9532-140-007	9532-140-007	1
9	Seal, Secondary V140A	9532-140-008	9532-140-008	1
10	Ring, Seal Mounting	9950-052-001	9950-052-001	1
11	Tub Back Mating Ring	9950-054-004	9950-054-004	1
11G	Mating Ring Guard Shield	9487-266-001	9487-266-001	1
12	Bolt, Tub End of Bearing Housing (7/16-14x1), Bolt from inside Tub	9545-059-004	9545-059-004	6
13	Washer, Flat	8641-581-034	8641-581-034	6
14	Screw-Hex Cap, 3/4"-10 x 3" (Bearing Housing to Frame)	9545-057-002	9545-057-002	6
15	Washers Spherical 3/4 (Male half) (Bearing Housing to Frame)	8641-588-001	8641-588-001	6
16	Washers Spherical 3/4 (Female half) (Bearing Housing to Frame)	8641-588-002	8641-588-002	6
15	Washer, Flat	8641-581-033		6
16	Lock Washer-Extrenal Tooth, 3/4" (Bearing Housing to Frame)	8641-582-020		6
17	Nut 3/4"-10 (Bearing Housing to Frame)	8640-418-003	8640-418-003	6
18	Pulley, Driven	9453-176-005	9453-176-005	1
19	Bolt, 3/8"-16 x 2"	9545-029-011	9545-029-011	3
20	Washer, 3/8"	8641-582-003	8641-582-003	3
21	Bushing Taperlock (Driven & Large)	9053-078-002	9053-078-002	1
22	Washer-Flat .675x2-1/2x1/4	8641-581-043	8641-581-043	1
23	Lockwasher-Exttooth, 5/8	8641-582-018	8641-582-018	1
24	Bolt, 5/8-11x1 1/2	9545-060-001	9545-060-001	1
25	Tub & Cylinder Assy Before Serial #535659	9869-023-003	9869-022-001	1
25	Tub & Cylinder Assy After Serial #535659	9869-027-004	9869-022-003	1

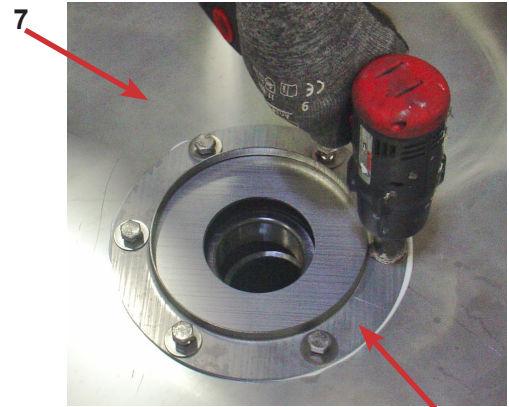
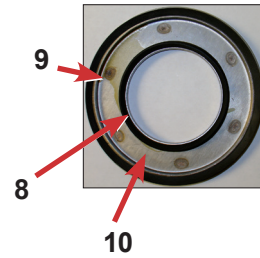
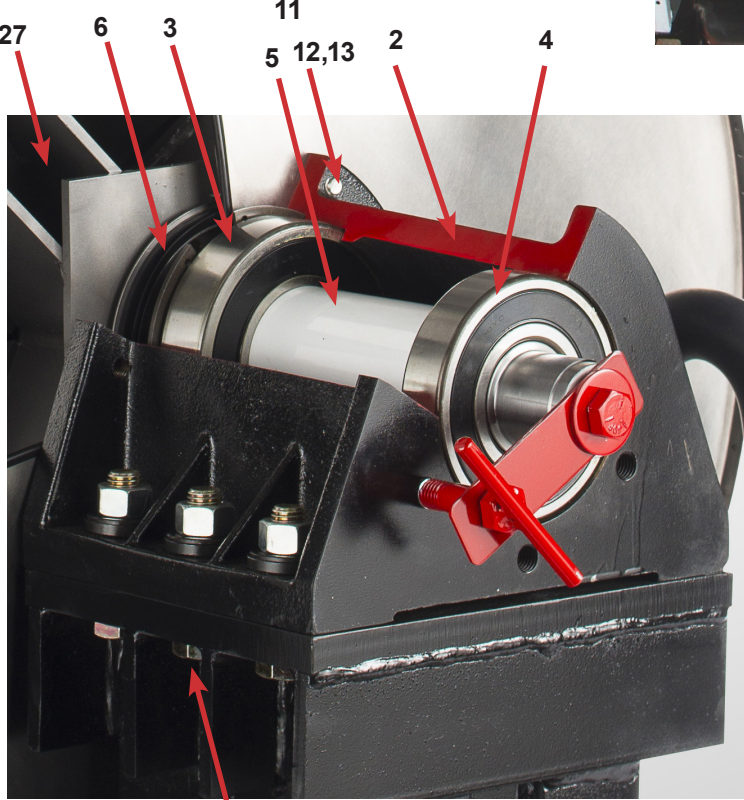
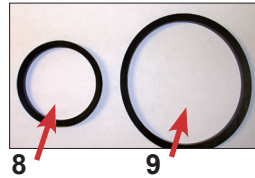
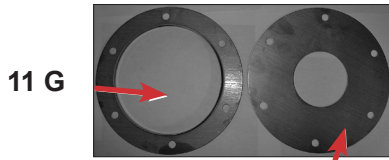
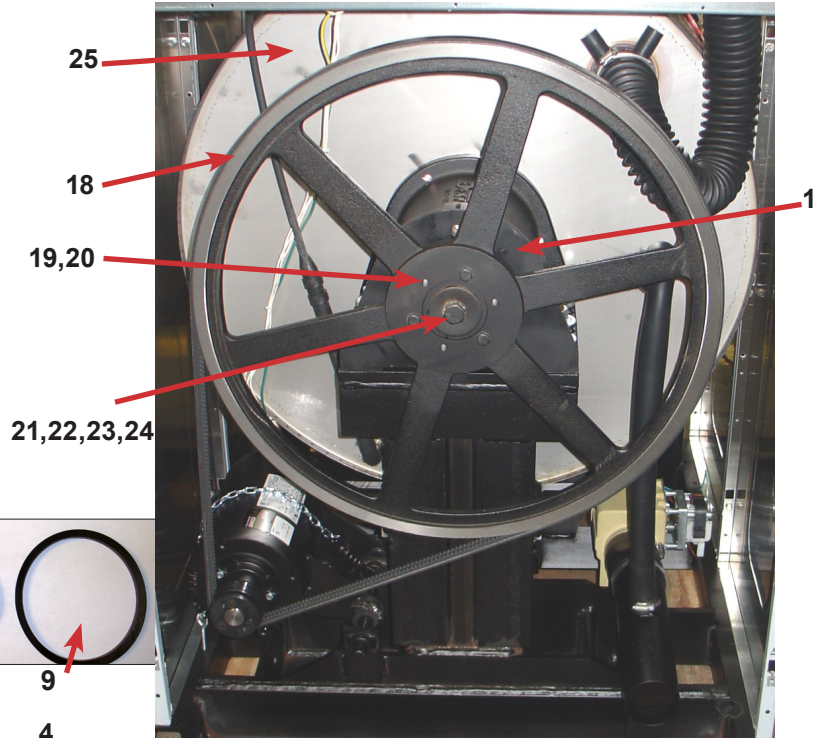
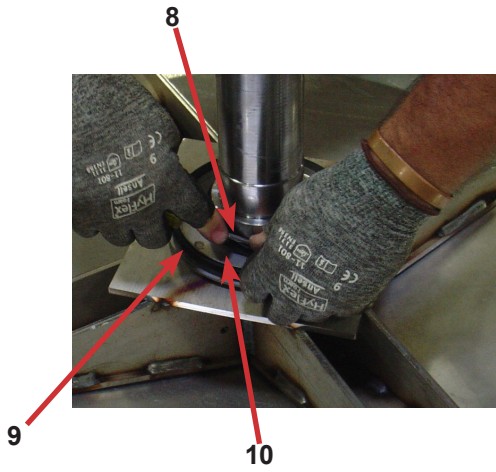

14,15,16,17

11

Key	Description	T-900	T-1200	QTY
27	Cylinder Assy	9848-136-001	9848-137-001	
*	Tub Front	9974-011-001	9974-011-002	1
*	Gasket, Tub Front	9206-421-002	9206-421-002	1
*	Ring Assy, Tub Mtg-Front Clamp	9950-055-001	9950-055-001	1
*	Bolt, Top Front Ring 3/8"-16 x 3"	9545-029-009	9545-029-009	1
*	Nut 3/8"-16	8640-415-001	8640-415-001	1

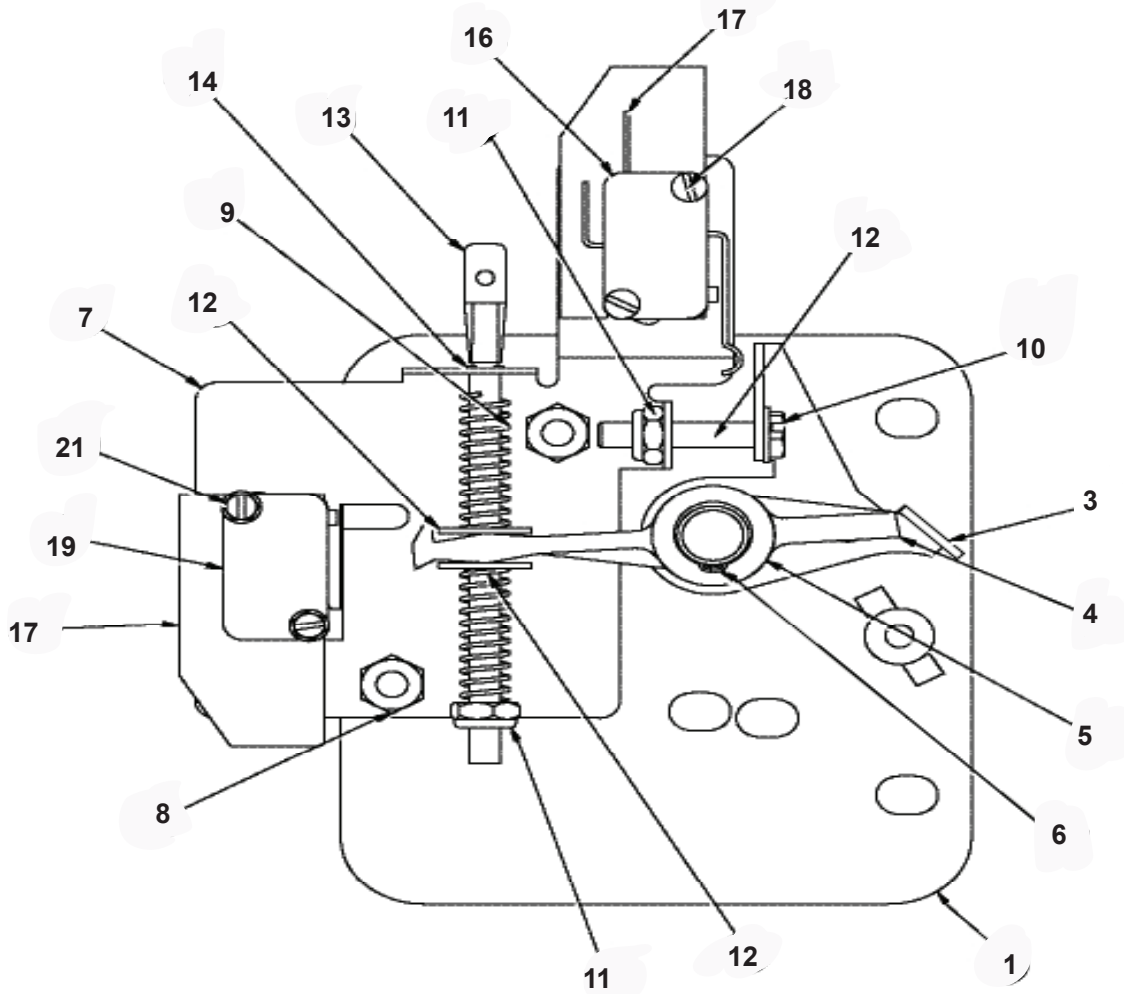

## Door Lock Assembly

Key	Description	All Models	QTY
33	Lock Assy, Complete (#1-22) (includes #1 thru #22)	9885-024-001	1
1	Plate Assy, Door Lock	9982-346-001	1
2	Washer, Flat (SS or Brass)	8641-581-030	1
3	Actuator, Latching Switch	9008-005-001	1
4	Pawl, Locking	9450-002-004	1
5	Washer, Spring	8641-569-003	1
6	Ring, Retaining	9487-200-004	1
7	Bracket Switch	9029-163-001	1
8	Nut, Hex 10-32 UNF	8640-413-002	2
9	Spring, Actuating	9534-364-002	1
10	Screw, Hx. 10-32 x 1"	9545-012-020	1
11	Nut, Elastic Stop 10-32	8640-413-004	2
12	Spring, Return	9534-364-001	2
13	Pin, Guide	9451-193-001	1

Key	Description	All Models	QTY
14	Ring, Retaining	9487-200-005	1
15	Washer	8641-581-031	1
16	Switch, Latching Sensing	9539-461-008	1
17	Shield, Switch	9550-169-003	3
18	Screw 4-40 x 5/8"	9545-020-001	2
18	Nut, Twin	8640-401-001	2
19	Switch, Locking Sensing	9539-461-007	2
20	Actuator, Switch Locking	9008-006-003	1
21	Screw 4-40 x 1 1/8"	9545-020-003	2
21	Spacer Sensor	9538-182-001	1
22	Pin, Dowel (for door cam)	9451-181-004	1
*	Shim, Door Lock, Thin	9552-037-001	AR
*	Screw, Lock mtg 1/4"-20 x 3/4"	9545-018-014	3
*	Lockwasher 1/4" Ext tooth	8641-582-007	3

# Gear Motor Door Lock Assembly

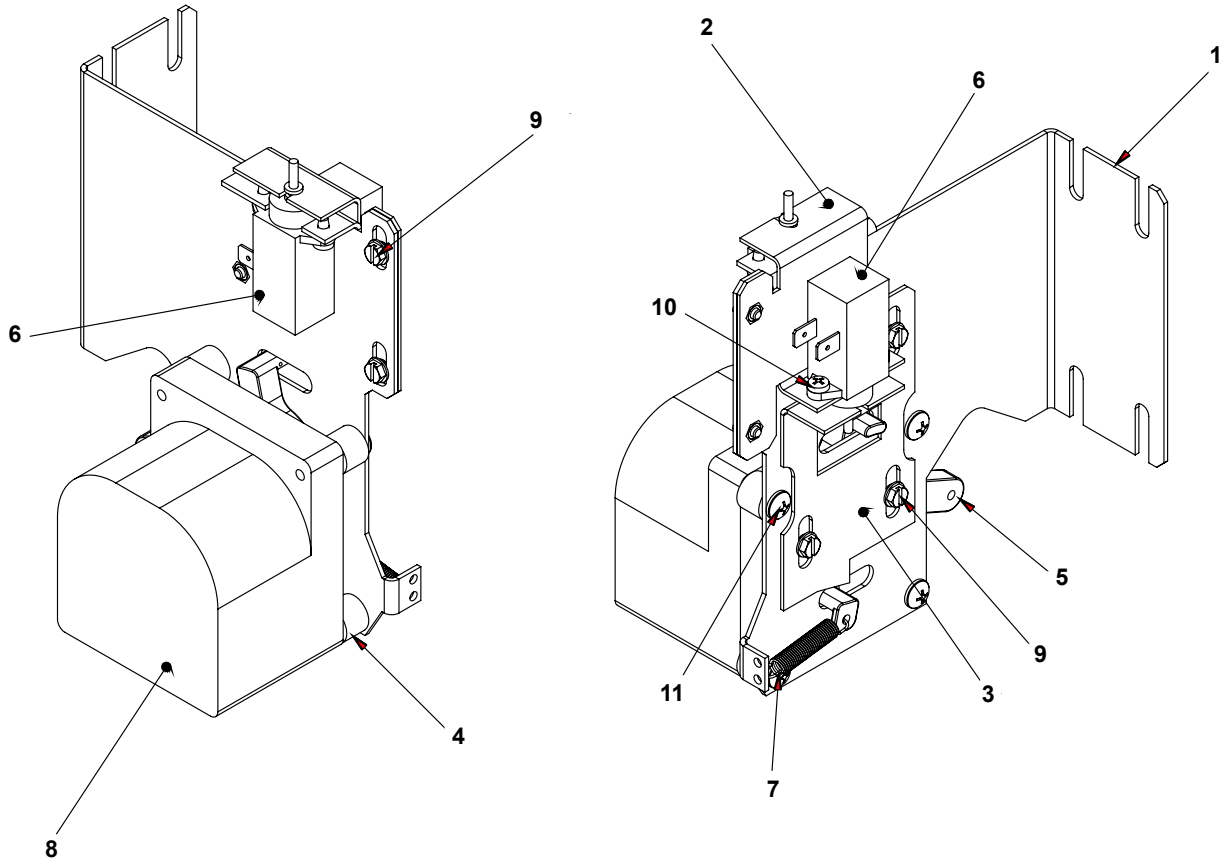

Key	Description	T-600	T-900	T-1200	QTY
*	Actuator Assembly (Includes 1-10, Rod NOT included)	9892-015-001	9892-015-001	9892-015-001	1
11	Screw Pnhdcr, 10-32 UNFx0 .75	9545-012-029	9545-012-029	9545-012-029	4
10	Cross Recessed PAn Hd Tapping screw	9545-031-011	9545-031-011	9545-031-011	4
9	Screw -Hxwshrhdslsems, 6-32 x 3/16	9545-044-003	9545-044-003	9545-044-003	6
8	Motor & Gear Assembly 120v	9914-137-015	9914-137-015	9914-137-015	1
7	Spring - Extension	9534-350-001	9534-350-001	9534-350-001	1
6	Thermoactuator - Door Lock Relay 120v	9586-001-001	9586-001-001	9586-001-001	2
5	Arm - Door Lock	9001-063-001	9001-063-001	9001-063-001	1
4	Spacer, Plastic	9538-157-021	9538-157-021	9538-157-021	4
3	Bracket Slide Lock	9029-204-001	9029-204-001	9029-204-001	1
2	Bracket Assy, Slide - Unlock	9985-189-001	9985-189-001	9985-189-001	1
1	Bracket Assy, Slide Lock Actuator	9985-190-001	9985-190-001	9985-190-001	1
*	Rod, Door Lock	9497-225-010	9497-225-013	9497-225-015	1

# Large Door & Hinge Group

Key	Description	T-900	T-1200	
1	Door Hinge Assembly (mounts to tub front)	9955-031-001	9955-031-001	1
*	Door Assembly Complete	9960-310-001	9960-310-001	1
2	Door Ring 180 degree large hnge	9487-275-001	9487-275-001	1
3	Door Gasket	9206-431-001	9206-431-001	1
4	Door Glass Window	9635-020-001	9635-020-001	1
*	Red Wire (Door Close Switch)	8220-063-028	8220-063-028	2
5	Switch, Door Hinge Close (Plunger)	9539-492-001	9539-492-001	1
6	Top Door Hinge Leaf (No pin)	9845-006-001	9845-006-001	1
7	Bottom Door Hinge Leaf	9845-007-001	9845-007-001	1
8	Thrd Form Screw, Door Mtg 5/16" x 5/8"	9545-056-002	9545-056-002	4
9	Screw, Loading Door Hinge Mtg (5/16" x9/16" ss)	9545-014-013	9545-014-013	3
10	Bracket Retainer support side panel	9029-191-001	9029-191-001	1
*	Shim Large door	9552-043-001	9552-043-001	1

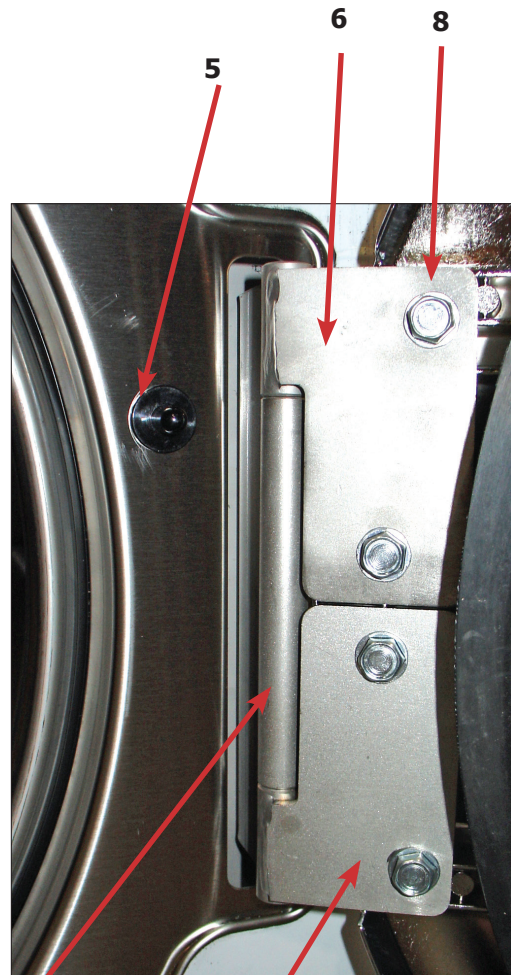
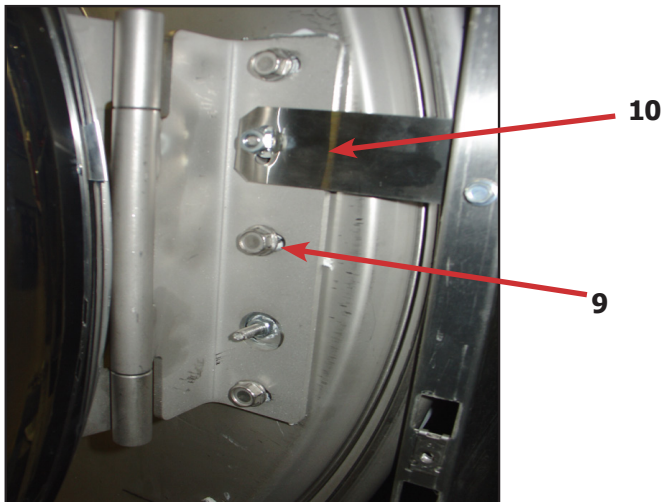

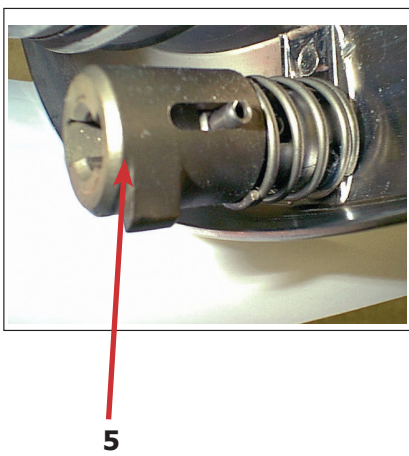
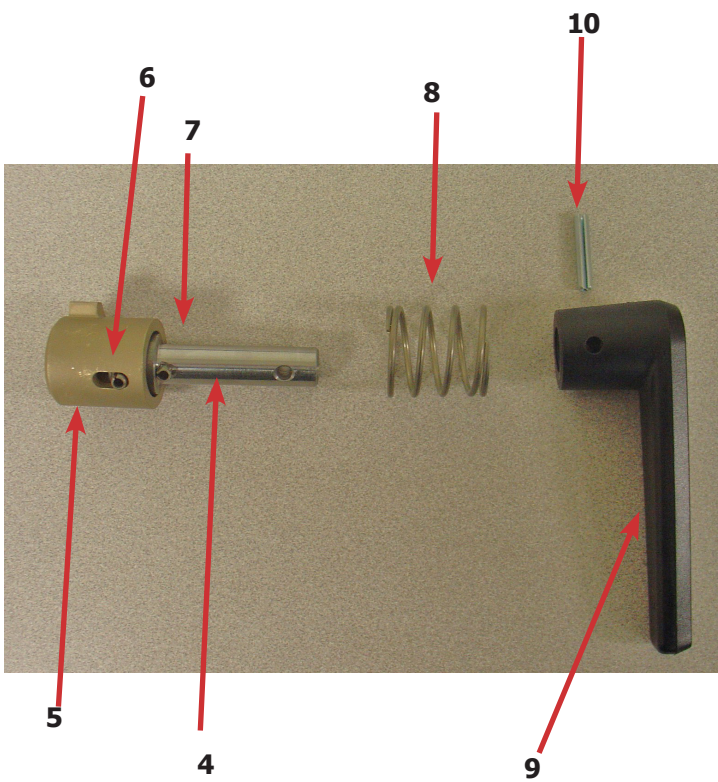
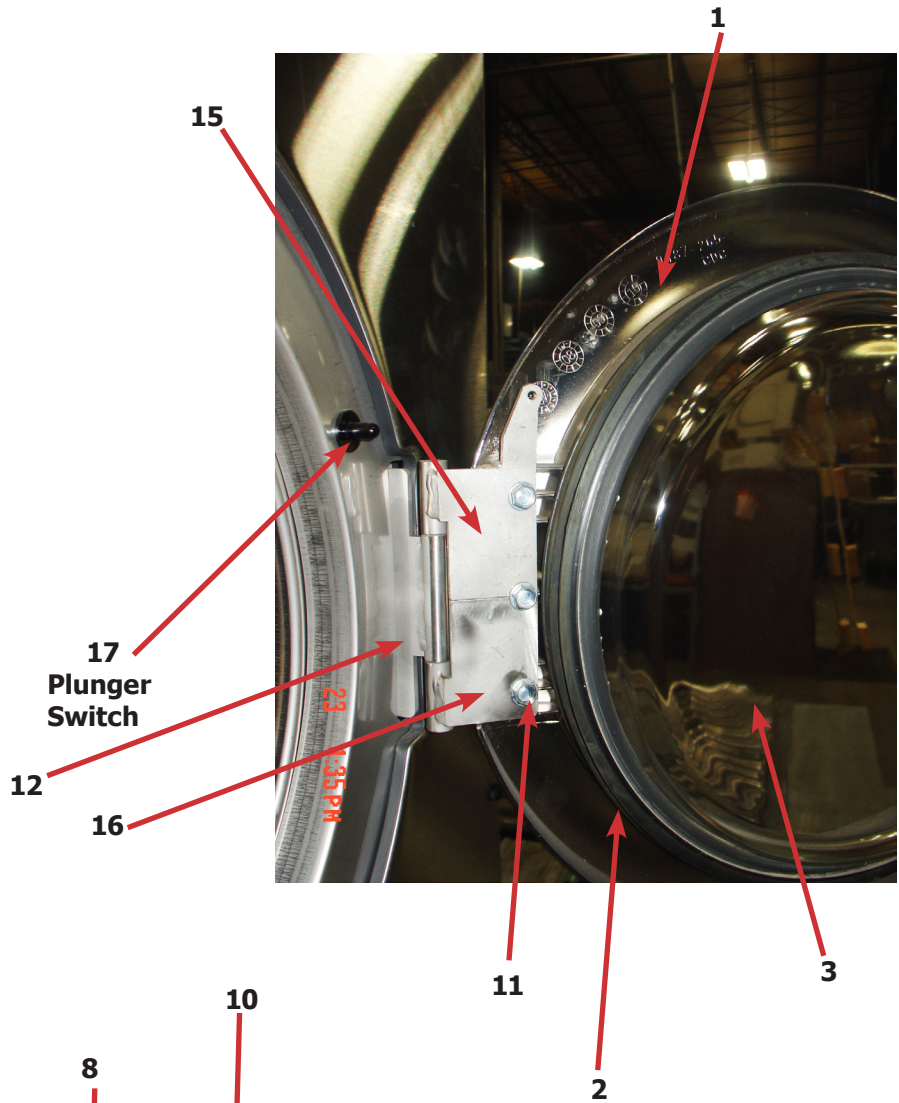

## Standard Loading Door & Hinge Group

	Door Size	Standard	Standard	Standard	
Key	Description	T-600	T-900	T-1200	QTY
*	Loading Door, Complete #1-10	9960-309-001	9960-310-001	9960-310-001	1
1	Loading Door, Ring	9487-265-002	9487-265-002	9487-265-002	1
2	Gasket, Loading Door	9206-419-001	9206-429-001	9206-429-001	1
3	Window, Loading Door	9635-016-001	9635-016-001	9635-016-001	1
*	Shaft Assy, Locking (includes 4 thru 7)	9913-134-003	9913-134-003	9913-134-003	1
4	Shaft, Door Locking	9537-195-002	9537-195-002	9537-195-002	1
5	Cam, Locking	9095-040-002	9095-040-002	9095-040-002	1
6	Roll Pin Type, Groove (1 1/4)	9451-181-005	9451-181-005	9451-181-005	1
7	Roll Pin Type, Groove (3/4)	9451-181-004	9451-181-004	9451-181-005	1
8	Spring, Lock Cam	9534-360-002	9534-360-002	9534-360-002	1
9	Handle, Door	9244-091-001	9244-091-001	9244-091-001	1
10	Roll Pin Type, Door Handle (groove)	9451-181-006	9451-181-006	9451-181-006	1
11	Thrd Form Screw, Door Mtg 5/16" x 5/8"	9545-056-002	9545-056-002	9545-056-002	3
*	Lockwasher 5/16" Ext hinge mtg	8641-582-009	8641-582-009	8641-582-009	3
*	Shim, Loading Door Hinge, Thin	9552-036-001	9552-043-001	9552-043-001	AR
12	Door Hinge Assembly Mounts to Tub Front	9955-030-001	9955-031-001	9955-031-001	1
*	Screw, Loading Door Hinge Mtg (5/16" -18x3/4" ss)	9545-014-009	9545-014-009	9545-014-009	3
*	Screw, Loading Door Hinge Mtg (5/16" x9/16" ss)		9545-014-013	9545-014-013	3
*	Wiring Harness doorlock safety switch assembly to I/O PCB Board	9627-893-001	9627-837-001	9627-891-001	1
*	Wire, BLK Door Close Switch	8220-063-026	8220-063-026		1
*	Wires, Red Door Close Switch	8220-063-025	8220-063-025		1
*	Wires, Red Door Closed Switch		8220-063-028	8220-063-028	2
15	Leaf, Door Hinge (Top)	9845-008-001	9845-005-004	9845-005-004	1
16	Leaf,, Door Hinge (Bottom)	9845-005-002	9845-005-002	9845-005-002	1
17	Switch,Door Hinge Close(Plunger)	9539-492-001	9539-492-001	9539-492-001	1



# Drain Valve Group Part # by Model

Key	Description	T-600	T-900	T-1200	QTY
1	Valve, Drain (includes #2 thru #11)	9379-202-001	9379-202-001	9379-202-001	1
2	Body, Valve (w/ball)	9064-070-001	9064-070-001	9064-070-001	1
3	Motor & Gear Train (complete)	9914-137-017	9914-137-017	9914-137-017	1
4	Plate, Motor Mtg	9452-538-001	9452-538-001	9452-538-001	1
5	Screw	8639-994-001	8639-994-001	8639-994-001	3
6	Spring, Drive	9534-339-001	9534-339-001	9534-339-001	1
7	Screw	9545-054-001	9545-054-001	9545-054-001	2
8	Screw	9545-054-002	9545-054-002	9545-054-002	1
9	Seal, V Packer	9532-134-001	9532-134-001	9532-134-001	2
10	Washer	8641-584-001	8641-584-001	8641-584-001	1
11	Pin, Main Drive	9451-196-001	9451-196-001	9451-196-001	1
*	Plate (spacers needed for replacement motor mtg. plate)	9538-149-001	9538-149-001	9538-149-001	4
13	Stator and Coil Assembly	9089-036-004	9089-036-004	9089-036-004	1

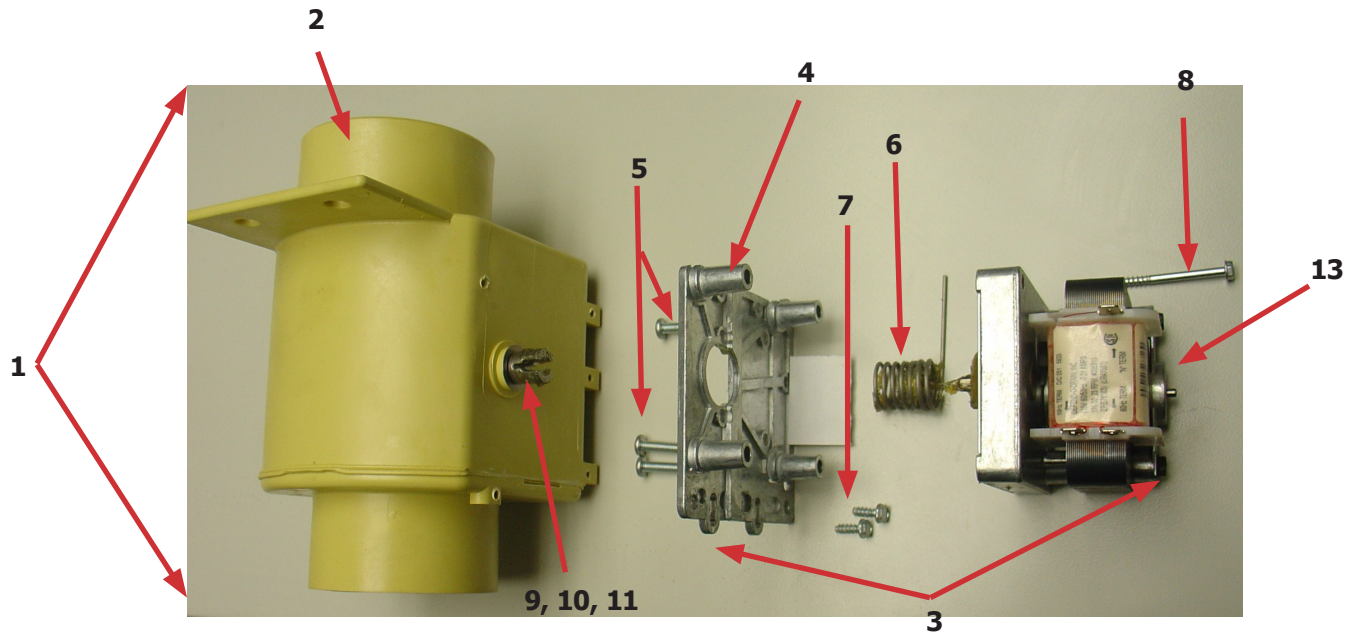

# Water Inlet Valve Breakdown Part # by Model

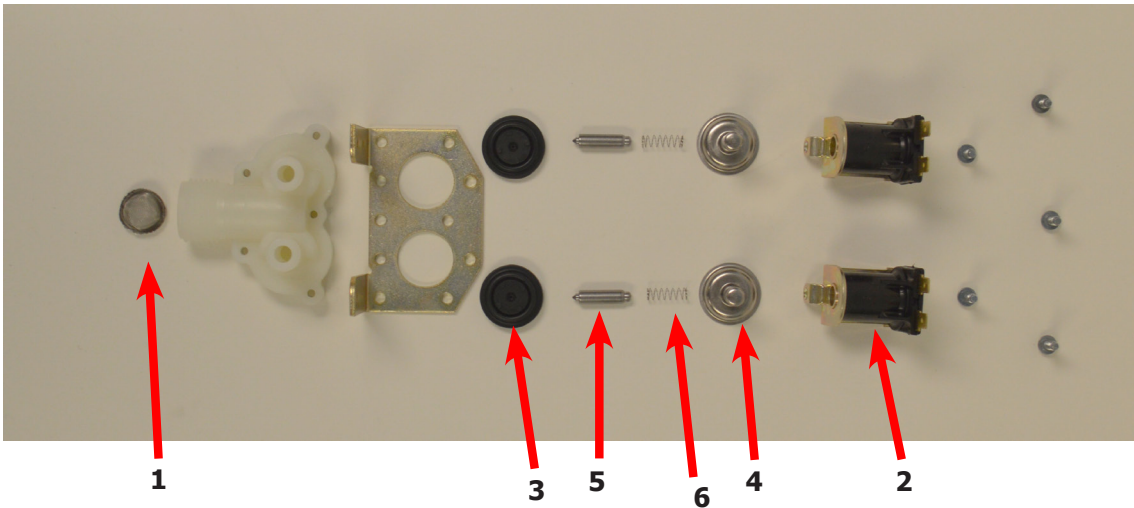

Key	Description	T-600	T-900	T-1200	QTY
*	Valve, Water Inlet (includes 1 thru 6)	9379-183-012	9379-183-012	9379-183-012	2
1	Screen, Inlet end of valve	9555-056-001	9555-056-001	9555-056-001	2
2	Coil Assy., 120 V Invensys	9089-017-001	9089-017-001	9089-017-001	2
*	Diaphragm Invensys (EPDM)	9118-049-001	9118-049-001	9118-049-001	2
*	Diaphragm Invensys (Viton)	9118-049-002	9118-049-002	9118-049-002	2
3	Diaphragm Invensys (EPDM NSF)	9118-049-003	9118-049-003	9118-049-003	2
4	Guide, Solenoid Invensys	9211-021-002	9211-021-002	9211-021-002	2
5	Armature Invensys	9015-008-001	9015-008-001	9015-008-001	2
6	Spring, Armature Invensys	9534-298-001	9534-298-001	9534-298-001	2

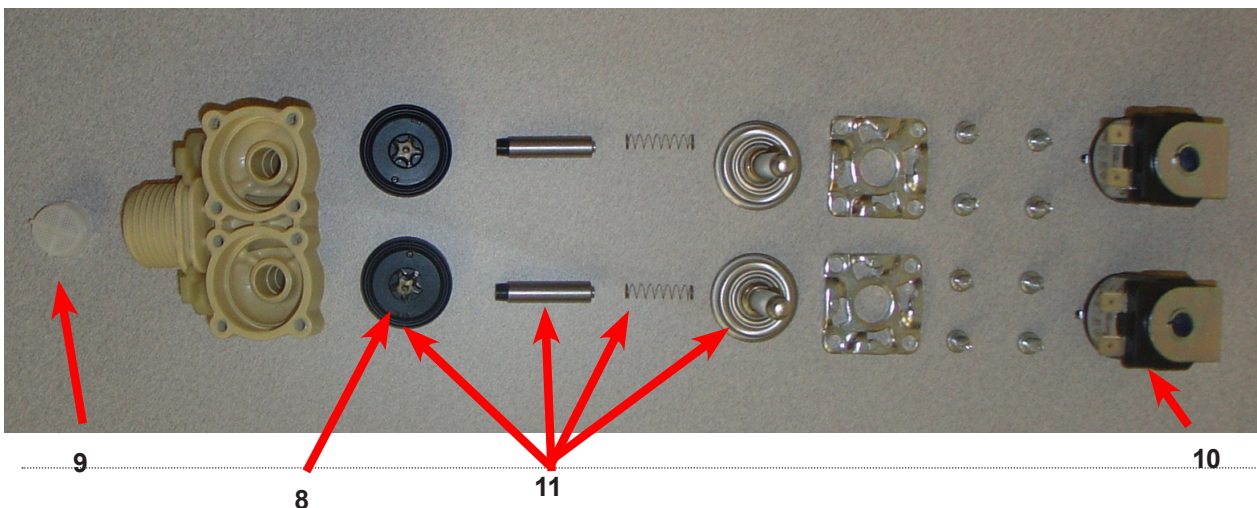

**Optional Water Valve**

Key	Description	T-600	T-900	T-1200	QTY
*	Dual Coil Water Valve Mueller	9379-192-001	9379-192-001	9379-192-001	1
7	Valve Water Body Complete(no coil)	9379-192-002	9379-192-002	9379-192-002	1
8	Diaphragm Mueller	9118-054-001	9118-054-001	9118-054-001	2
9	Filter Mueller	9183-046-001	9183-046-001	9183-046-001	2
10	Coil Mueller	9089-051-001	9089-051-001	9089-051-001	2
11	Diaphragm Assembly Mueller Includes	9785-001-001	9785-001-001	9785-001-001	2

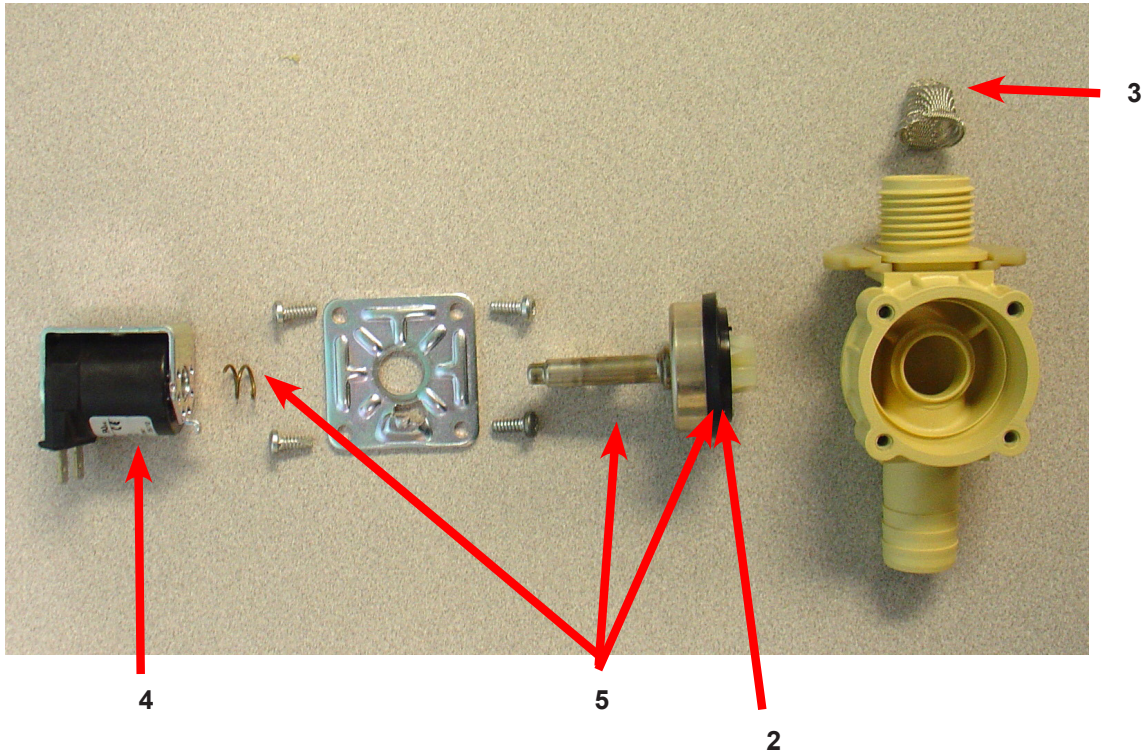

Key	Description	T-600	T-900	T-1200	QTY
*	Single Coil Water Valve Mueller		9379-194-001	9379-194-001	2
1	Valve Water Body Complete (no coil)		9379-194-002	9379-194-002	2
2	Diaphragm Mueller		9118-055-001	9118-055-001	1
3	Filter Mueller		9183-046-001	9183-046-001	1
4	Coil Mueller		9089-051-001	9089-051-001	1

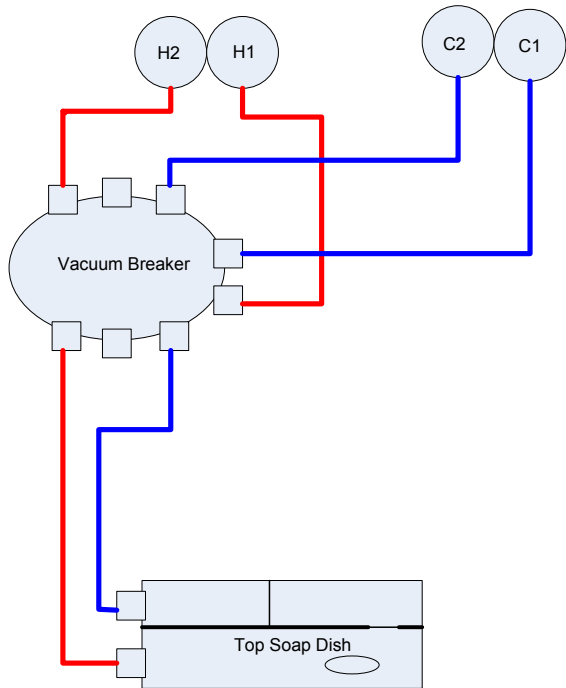
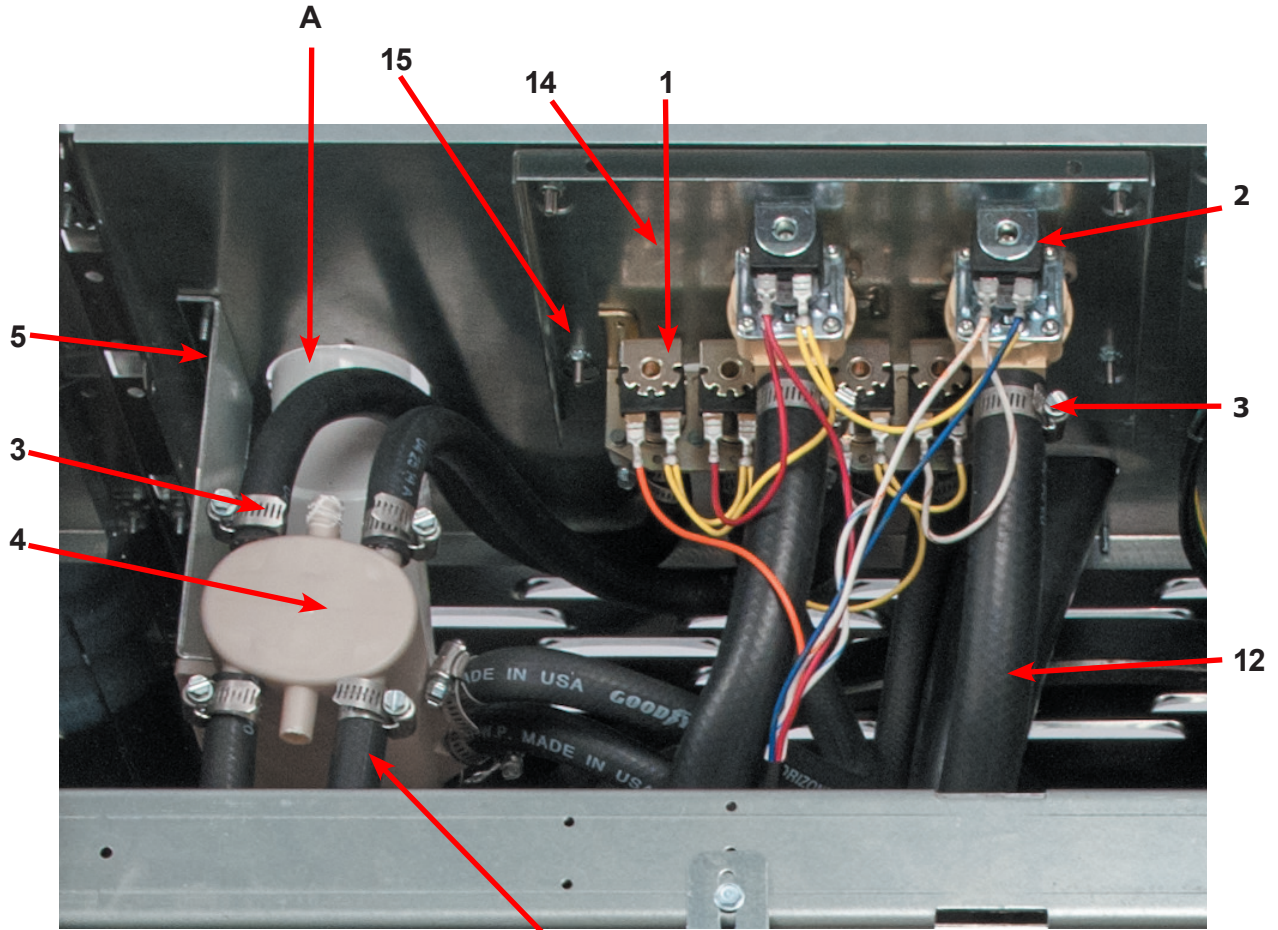

Top Soap Box Design

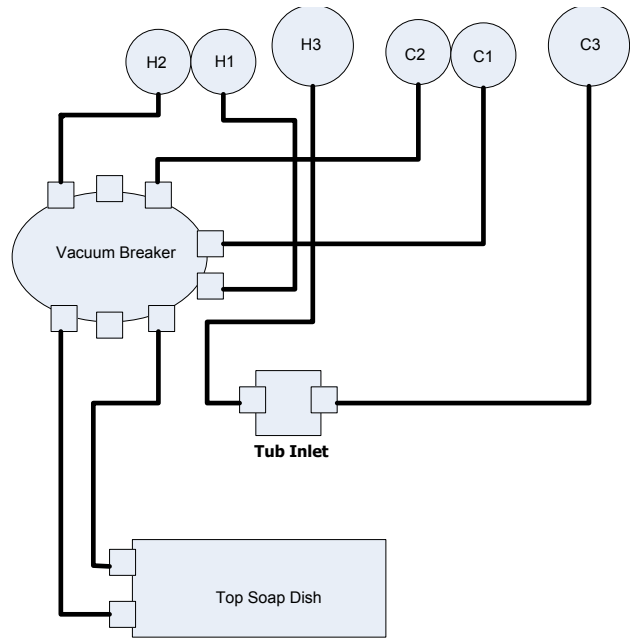

Top Soap Box 4 Valve Design

# Water Inlet Part # by Model

Key	Description	T600	T900	T1200	QTY
A	Injector Assembly	9883-009-001	9883-012-001	9885-012-001	1
1	Valve, Water Inlet (dual outlet) (see Water Inlet Valve Breakdown for individual parts)	9379-183-012	9379-183-012	9379-183-012	2
*	Screw, Valve Mtg	9545-008-026	9545-008-026	9545-008-026	2
2	Valve Water Inlet (single outlet)			9379-194-001	2
*	Screw, Valve M4x0.7x8mm			9545-064-001	8
3	Clamp-Water Valves	8654-117-008	8654-117-008	8654-117-008	AR
*	Shield over Water Valves Plastic	9550-194-001	9550-195-001	9550-195-001	1
*	Clip-Push	9083-121-001			3
*	Clip-Push		9083-121-001	9083-121-001	4
4	Vacuum Breaker	9610-001-001	9610-001-001	9610-001-002	1
5	Bracket, Vacuum Breaker	9029-077-001	9029-077-001	9029-077-001	1
*	Screw	9545-008-026	9545-008-026	9545-008-026	4
6	New Front Mount Soap Box, 2 port			9732-290-001	1
7	Fitting, Cross (new soap box)			8615-118-001	
*	Clamp, Vacuum Breaker End	8654-117-014	8654-117-014	8654-117-014	1
9	Hose, Vacuum Breaker to Tub Injection Tube	9242-461-001	9242-461-001	9242-461-001	1
10	Flow restrictor	9475-002-002	9475-002-002	9475-002-002	2
13	Flow restrictor		9475-002-002	9475-002-003	3
14	Plate-Water Valves, Mounting	9452-813-001	9452-814-001	9452-814-001	1
15	Nut, #10-32UNF, 2B	8460-413-002	8460-413-002	8460-413-002	4

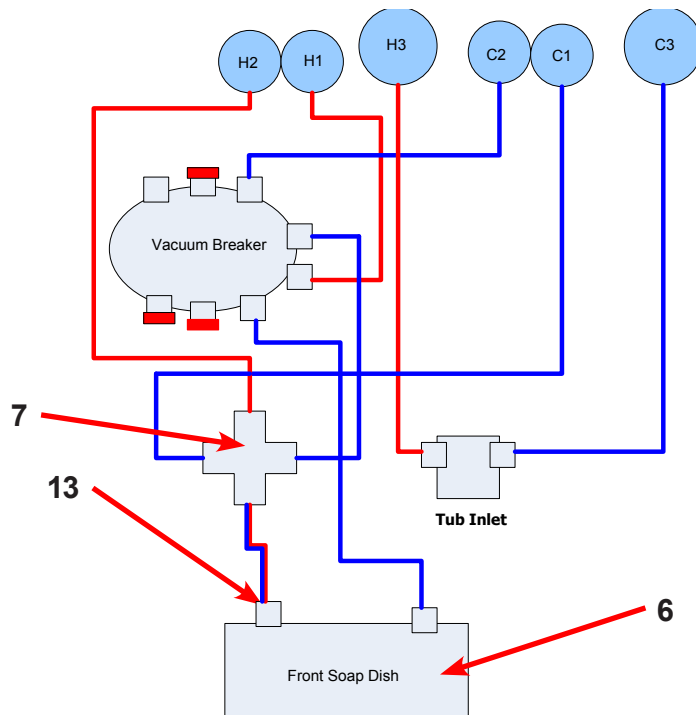

New Front Soap Box Design

## Chassis and Drain Part # T-600

Key	Description	T-600	QTY
1	Base Assy,Frame	9945-097-002	1
2	Outer Tub Assy	9930-164-001	1
*	Tub & Cylinder Assy	9869-033-001	1
3	Ring Assy, Tub Mtg-Front	9950-051-004	1
4	Ring Assy.Clamp Tub Mtg.- Rear	9950-056-002	1
5	Bolt, 1/2" x 1 1/4 Rings to Base		4
6	Nut, Wizlock, 1/2-13	8640-417-005	1
7	Hose, Tub to Drain Valve	9242-456-001	1
8	Clamp, Hose (Tub to Drain Valve)	8654-117-014	2
9	Valve, Drain	9379-202-001	1
10	Hose, Drain Valve to Tube	9242-457-001	1
11	Clamp, Hose (Drain Valve to Tube)	8654-117-014	2
12	Bracket, Drain Valve	9029-052-001	1
*	Screw, Valve to Bracket 12ABx1/2	9545-008-026	2
13	Tube Assy, Drain	9915-118-002	1
*	Screw Tube (Bracket to Base 1/4Bx3/4	9545-030-002	2
14	Hose, Overflow to drain	9242-449-002	1
*	Clamp, Overflow	8654-117-018	2
*	Lockwasher	8641-582-018	4
*	Nut, Hex 5/8-11	8640-425-001	4
*	Shim, Support Assembly (thin)	9552-038-001	AR
15	Fill Hose, Vacuum Brkr. to Tub		1
16	Dispenser Soap	9122-005-004	1
17	Gasket, Dispenser	9206-416-001	1
*	Nut Spring SS	8640-399-007	4
*	Screw, Disp. Mtg	9545-008-012	4
*	Hose, Dispenser to Tub	9242-450-001	1
*	Clamp, Dispenser Hose	8654-117-008	2
18	Back Ass'y, Tub	9962-013-001	1
19	Bolt, 7/16" x 2" Tub Back to Tub	9545-029-003	12
20	Nut, Flange Lock	8640-416-005	12
21	Hose, Pressure Switch	9242-175-002	1
*	Clamp, Pressure Switch Hose	8654-117-015	1

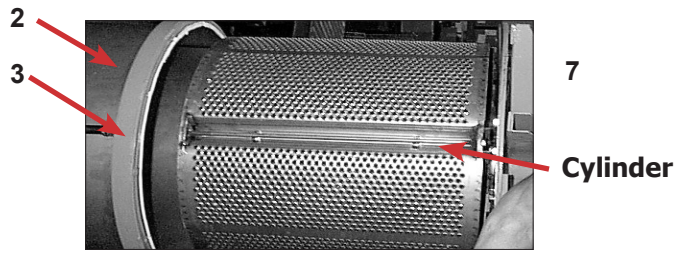
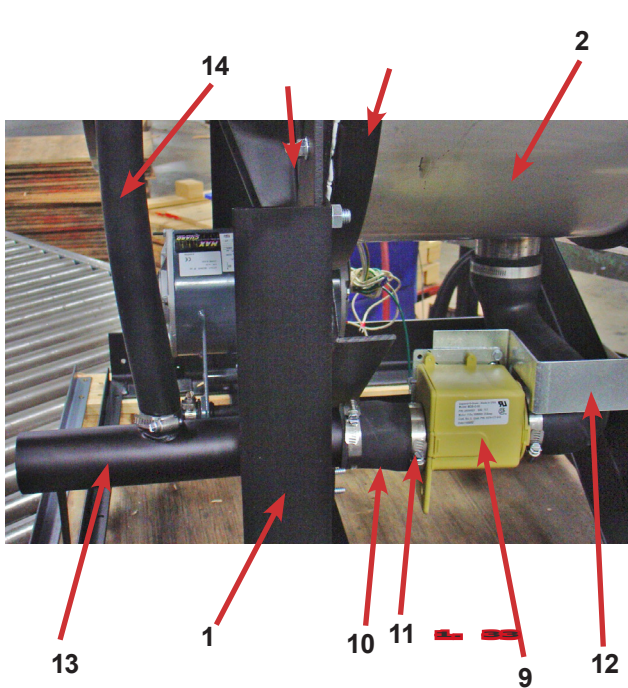

Cylinder

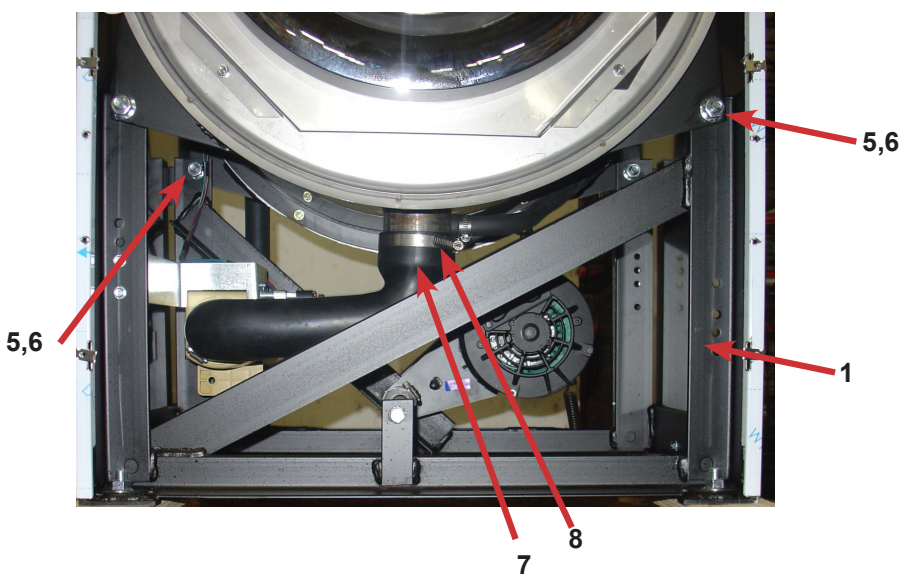
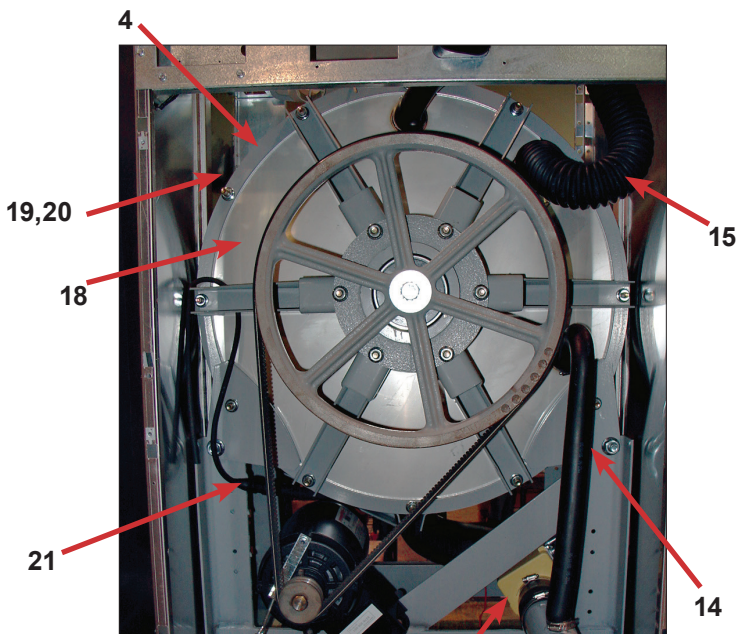
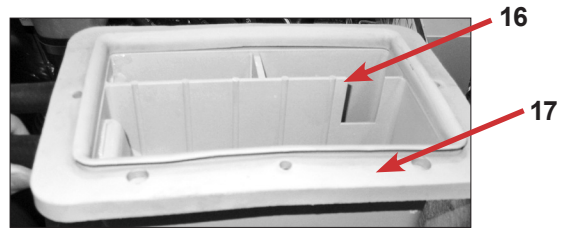

## Chassis and Drain Part # by Model

Key	Description	T-900	T-1200	QTY
1	Base Assy,Frame	9945-128-002	9945-125-002	1
2	Outer Tub Assy Before Serial #535659	9930-147-001	9930-150-001	1
2	Outer Tub Assy After Serial #535659	9930-158-001	9930-154-001	1
*	Tub & Cylinder Assy Before Serial #535659	9869-023-003	9869-022-001	1
*	Tub & Cylinder Assy After Serial #535659	9869-027-003	9869-022-003	1
3	Tub Front Before Serial #535659	9974-011-001	9974-011-001	1
3	Tub Front After Serial #535659	9974-011-001	9974-011-001	1
*	Gasket, Tub Front	9206-421-002	9206-421-002	1
4	Ring Assy, Tub Mtg-Front Clamp	9950-055-001	9950-055-001	1
5	Bolt, Top Front Ring 3/8"-16 x 3"	9545-029-009	9545-029-009	1
6	Nut WCAD 3/8"-16	8640-415-001	8640-415-001	1
7	Ring Assy.Clamp Tub Mtg. to Frame	9950-053-002	9950-053-002	1
8	Bolt, 1/2" -13 x 2" Ring	9545-017-013	9545-017-013	1
9	Nut, 1/2" -13 Ring	8640-417-005	8640-417-005	1
10	Bolt, 1/2" -13 x 2" Rings to Base	9545-017-013	9545-017-013	2
11	Nut, Wizloc 1/2" x 13	8640-417-005	8640-417-005	2
12	Washer, Flat 1/2"	8641-581-026	8641-581-026	2
13	Hose, Tub to Drain Valve	9242-459-001	9242-459-001	1
14	Clamp, Hose (Tub to Drain Valve)	8654-117-014	8654-117-014	2
15	Valve, Drain	9379-202-001	9379-202-001	1
*	Screw, Valve to Base 1/4ABx3/4	9545-030-002	9545-030-002	2
*	Washer, Flat 1/4	8641-581-018	8641-581-018	2
16	Hose, Drain Valve to Tube	9242-457-001	9242-457-001	1
*	Clamp, Hose (Drain Valve to Tube	8654-117-014	8654-117-014	2
17	Tube Assy, Drain	9915-120-004	9915-126-002	1
18	Clamp, Hose (Tube to Frame Bracket)	8654-117-014	8654-117-014	1
*	Bracket, Drain Tube	9029-162-002		1
*	Screw Tube (Bracket to Base 1/4Bx3/4)	9545-030-002	9545-030-002	4
19	Hose, Overflow Tub To Drain Tube	9242-449-003	9242-449-003	1
*	Clamp, Hose	8654-117-018	8654-117-018	2
20	Tube, Suds overflow	9242-463-004	9242-463-004	1
*	Clamp, Hose	8654-117-008	8654-117-008	2
21	Hose, Pressure switch	9242-175-007	9242-175-004	1
	Clamp, Hose	8654-117-015	8654-117-015	1



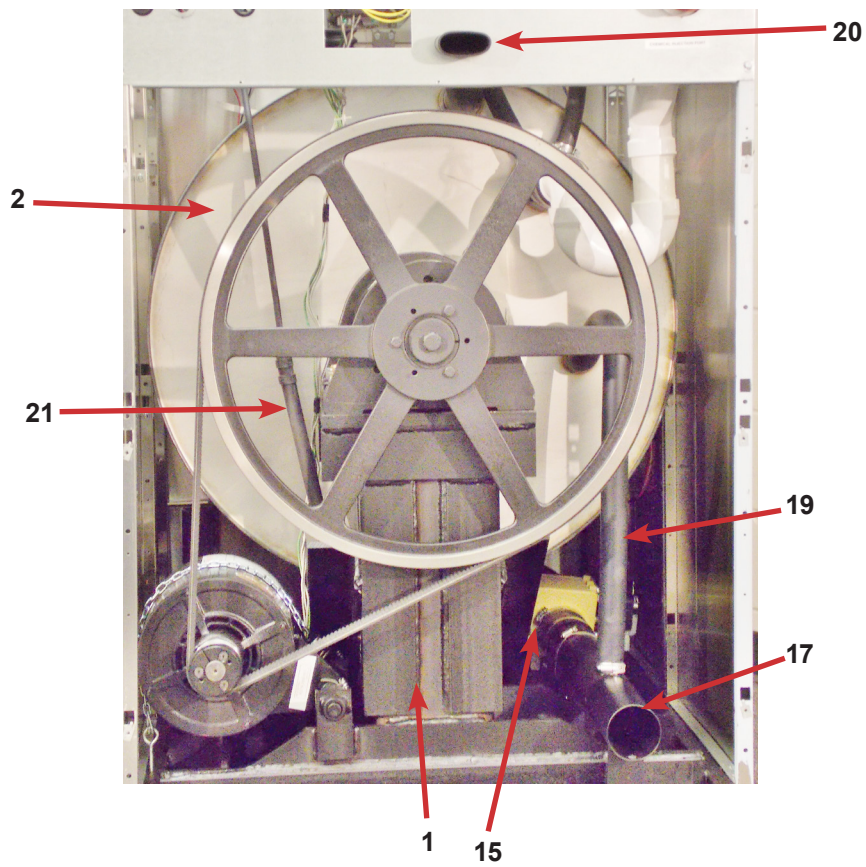
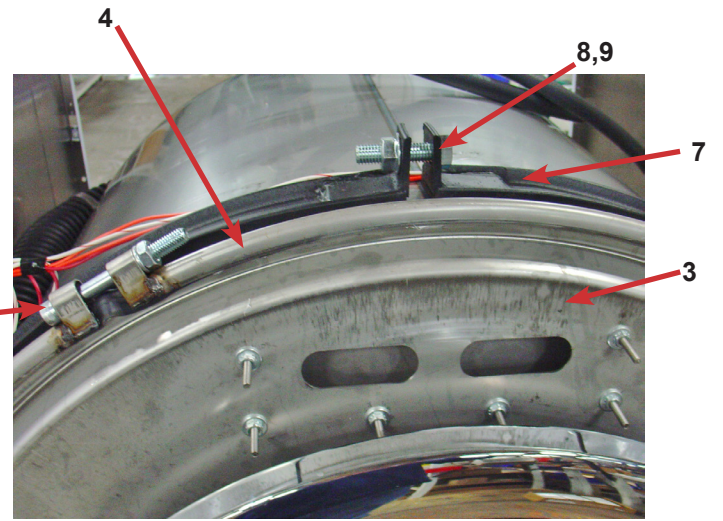
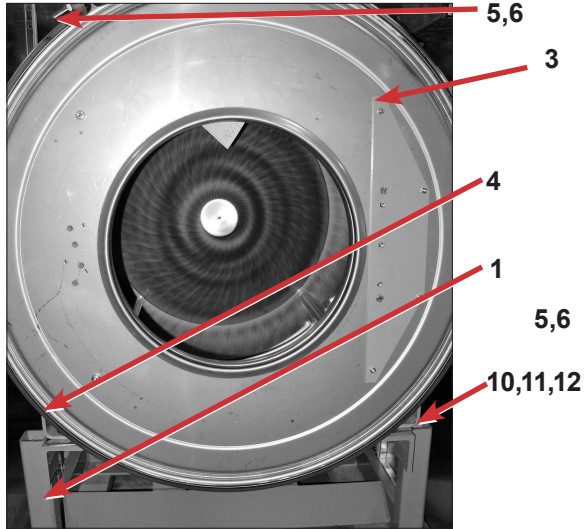
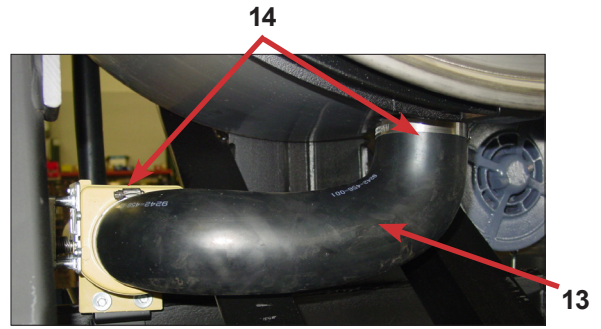
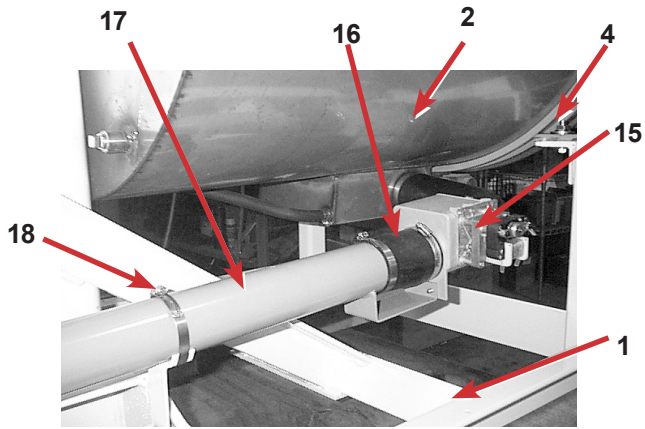

# Electrical Components - Top Compartment

## Mechanical Pressure switch

Key	Description	T-600	T-900	T-1200	QTY
*	Front Panel Control Assembly	9989-463-001	9989-456-001	9989-456-001	1
1	Ribbon Cable	9500-001-001	9500-001-001	9500-001-001	2
2	PCB I/O interface	9799-003-001	9799-003-001	9799-003-001	1
3	PCB CPU (Main Control)	9799-002-003	9799-002-003	9799-002-003	1
4	Harness CPU to I/O Power	9627-706-001	9627-706-001	9627-706-001	1
5	Harness Trough	9627-697-001	9627-697-001	9627-697-001	1
6	Harness Door Lock CPU	9627-837-001	9627-892-001	9627-892-001	1
7	Relay (Run)	5192-285-003	5192-285-003	5192-285-003	1
*	Screws Mtg I/O & CPU	9545-008-001	9454-008-001	9454-008-001	8
*	Diode Wire Assembly	8220-001-442	8220-001-442	8220-001-442	1
8	Pressure Switch	9501-009-003	9501-009-004	9501-009-004	1
*	Bracket Pressure Switch Mtg	9029-071-001	9029-071-001	9029-071-001	1
9	Harness Pressure Switch	9627-704-001	9627-704-001	9627-704-001	1
*	Trough Assy,Controls 208-240 V	9857-214-003	9857-216-005	9857-217-003	1
*	Trough only	9839-014-001	9839-014-001	9839-016-001	1
*	Screw,Trough Sides & Tranformer	9545-008-026	9545-008-026	9545-008-026	7
*	Lockwasher Exttooth #10	8641-582-006	8641-582-006	8641-582-006	7
10	Angle Support Trough Bracket	9003-061-001	9029-061-001	9029-061-001	1
*	Angle Trough to Rear Channel Bracket	9029-229-001	9003-229-001		1
*	Screw,10Bx1/4 rear channel bracket	9545-008-001	9545-008-001		2
*	Screw, Trough Bracket	9545-008-026	9545-008-026	9545-008-026	3
11	Transformer, Control (Primary Voltage to 115 volts)	8711-004-001	8711-004-001	8711-004-001	1
*	Screw, Mtg #8Bx1/4"	9545-045-001	9545-045-001	9545-045-001	2
*	Lockwasher	8641-582-005	8641-582-005	8641-582-005	2
12	Screw GRN. #10-32x 1/2"	9545-008-027	9545-008-027	9545-008-027	1
*	Lockwasher #10	8641-582-006	8641-582-006	8641-582-006	1
*	Lug, Grounding	8652-130-037	8652-130-037	8652-134-001	1
13	Transformer, Secondary (120v to 12vac)	8711-003-001	8711-003-001	8711-003-001	1
*	Harness Control VF Shield RED	9627-810-001	9627-810-001	9627-810-001	1
*	Bushing 3/4 Trough	9053-067-001	9053-067-001	9053-067-001	1
*	Bushing , Wire 7/8	9053-067-002	9053-067-002	9053-067-002	2
14	Dynamic Braking Resistor	9483-004-002	9483-004-003	9483-004-003	2
15	Screws #10-32x1/2" (pnhdcr) BR	9545-012-008	9545-012-008	9545-012-008	4
15	Nuts, #10-32 UNF 2B BR	8640-413-002	8640-413-002	8640-413-002	4
*	Screw #6-32x5/16"	9545-044-006	9545-044-006	9545-044-006	4
*	Nuts Hex #6-32	8640-411-003	8640-411-003	8640-411-003	4
*	Trml Blok Assy, POWER at rear	9897-033-002	9897-033-002	9897-033-002	1
16	PCB Display	9799-001-001	9799-001-001	9799-001-001	1
17	Harness, CPU to Display	9627-705-001	9627-705-001	9627-705-001	1

# Electrical Components - Top Compartment

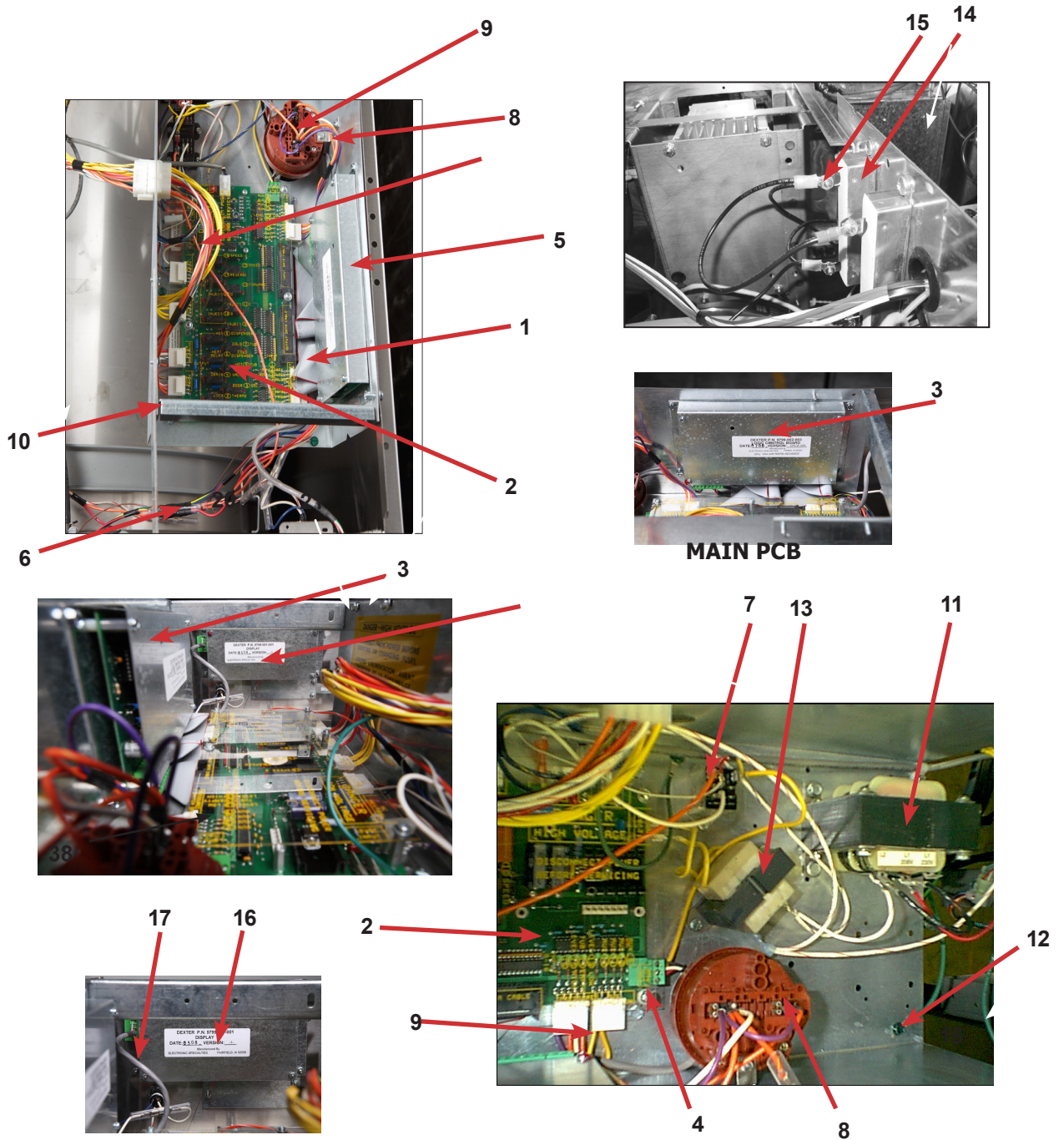

Key	Description	T-600	T-900	T-1200	QTY
*	Harness Power Trml Blok	9627-747-003	9627-747-003	9627-747-002	1
*	Screw #6 AB x 3/4 Mtg Trml Blok	9545-031-001	9545-031-010	9545-031-010	1
*	Screw, Mtg 8Bx3/8"	9545-045-007	9545-045-007	9545-045-007	2
*	Strip, Terminal Marker	9558-025-001	9558-025-001	9558-025-001	1
*	Screw, Mtg #8Bx1/4"	9545-045-001	9545-045-001	9545-045-001	2
*	Terminal Block Assy Injector	9897-032-002	9897-032-002	9897-032-002	1
*	Cover Electrical	9074-267-001	9074-267-001	9074-267-001	1
*	Plastic Shield Over Water Valve	9550-194-001	9550-195-001	9550-195-001	1
*	Standoff Twistlock	9527-002-003	9527-002-003	9527-002-003	2
*	Standoff Twistlock	9527-002-002	9527-002-002	9527-002-002	3

# Electrical Components - Top Compartment Electronic Pressure Sensor

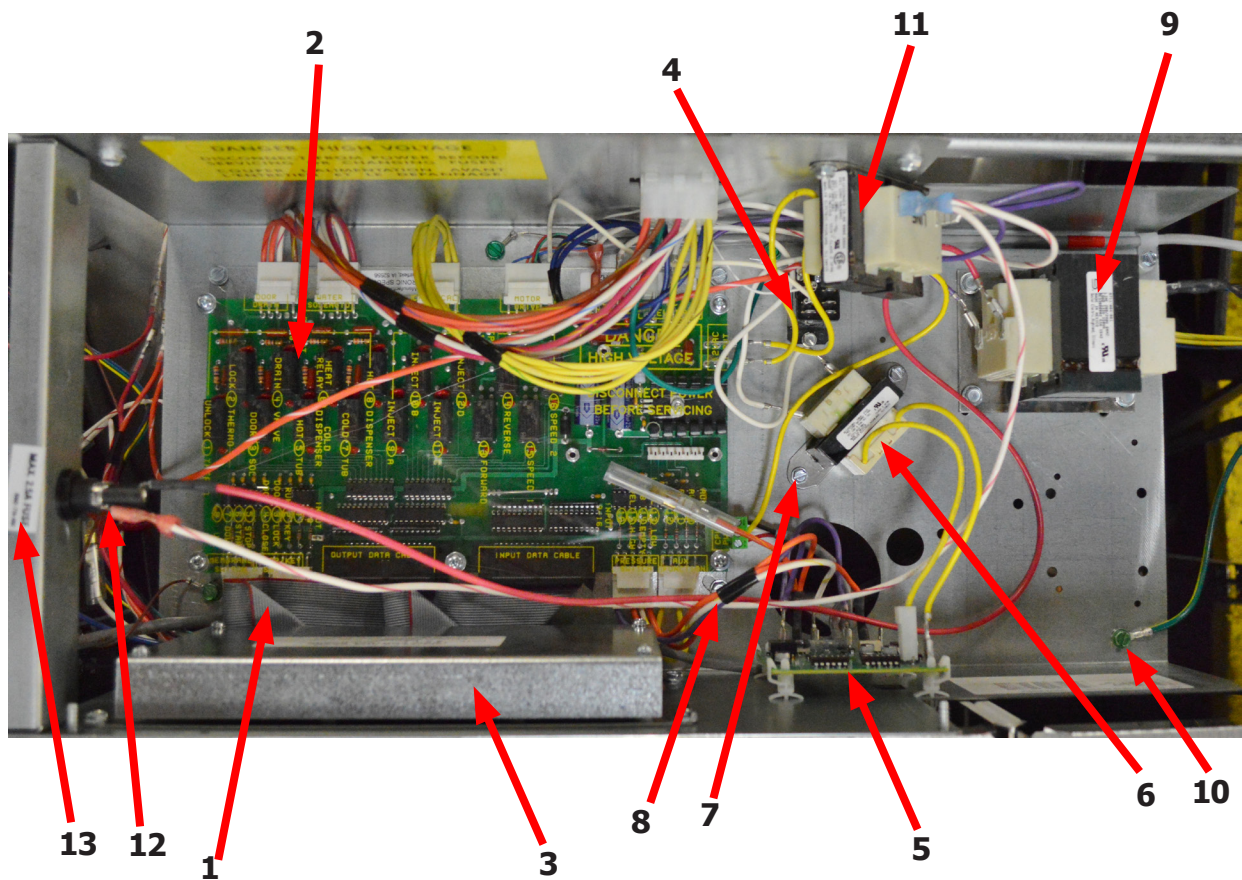

Key	Description	T-600	T-900	T1200	QTY
*	Trough Assy,Controls 208-240 V	9857-214-003	9857-216-005	9857-217-003	1
*	Trough only	9839-014-001	9839-014-001	9839-016-001	1
*	Screw,Trough Sides & Tranformer	9545-008-026	9545-008-026	9545-008-026	7
*	Lockwasher Exttooth #10	8641-582-006	8641-582-006	8641-582-006	7
1	Ribbon Cable	9500-001-001	9500-001-001	9500-001-001	2
2	PCB I/O interface	9799-003-001	9799-003-001	9799-003-001	1
3	PCB CPU (Main Control)	9799-002-003	9799-002-003	9799-002-003	1
*	Harness CPU to I/O Power	9627-706-001	9627-706-001	9627-706-001	1
*	Harness Trough	9627-697-001	9627-697-001	9627-697-001	1
*	Harness Door Lock CPU	9627-837-001	9627-892-001	9627-892-001	1
4	Relay (Run)	5192-285-003	5192-285-003	5192-285-003	1
*	Screws Mtg I/O & CPU	9454-008-001	9454-008-001	9454-008-001	8
*	Diode Wire Assembly	8220-001-442	8220-001-442	8220-001-442	1
*	Kit-Pressure Sensor, Electronic	9732-314-001	9732-314-001	9732-314-001	1
5	Kit-Repaacement, Pressure Sensor (only)	9732-315-001	9732-315-001	9732-315-001	1
*	Support-PCB, 3/8", Edge Holding	9458-285-001	9458-285-001	9458-285-001	4
6	Transformer-120/18VAC, 5 VA	8711-015-001	8711-015-001	8711-015-001	1
7	Screw, 8B x 1/4	9545-045-001	9545-045-001	9545-045-001	2
*	Wire Assy BLK/BLU	8220-001-233	8220-001-233	8220-001-233	1
*	Wire Assy RED/BLU	8220-001-232	8220-001-232	8220-001-232	1
8	Harness Pressure Switch	9627-704-001	9627-704-001	9627-704-001	1
*	Angle Support Trough Bracket	9029-061-001	9029-061-001	9029-061-001	1
*	Angle Trough to Rear Channel Bracket	9003-229-001	9003-229-001		1
*	Screw,10Bx1/4 rear channel bracket	9545-008-001	9545-008-001		2
*	Screw, Trough Bracket	9545-008-026	9545-008-026	9545-008-026	3
9	Transformer, Control (Primary Voltage to 115 volts)	8711-004-001	8711-004-001	8711-004-001	1
*	Screw, Mtg #8Bx1/4"	9545-045-001	9545-045-001	9545-045-001	2
*	Lockwasher	8641-582-005	8641-582-005	8641-582-005	2
10	Screw GRN. #10-32x 1/2"	9545-008-027	9545-008-027	9545-008-027	1
10	Lockwasher #10	8641-582-006	8641-582-006	8641-582-006	1
10	Lug, Grounding	8652-130-037	8652-130-037	8652-134-001	1
11	Transformer, Secondary (120v to 12vac)	8711-003-001	8711-003-001	8711-003-001	1
*	Harness Control VF Shield RED	9627-810-001	9627-810-001	9627-810-001	1
*	Bushing 3/4 Trough	9053-067-001	9053-067-001	9053-067-001	1
*	Bushing , Wire 7/8	9053-067-002	9053-067-002	9053-067-002	2
*	Dynamic Braking Resistor	9483-004-002	9483-004-003	9483-004-003	2
*	Screws #10-32x1/2" (pnhdcr) BR	9545-012-008	9545-012-008	9545-012-008	4
*	Nuts, #10-32 UNF 2B BR	8640-413-002	8640-413-002	8640-413-002	4
*	Screw #6-32x5/16"	9545-044-006	9545-044-006	9545-044-006	4
*	Nuts Hex #6-32	8640-411-003	8640-411-003	8640-411-003	4
*	Trml Blok Assy, POWER at rear	9897-033-002	9897-033-002	9897-033-002	1
*	Harness, CPU to Display	9627-705-001	9627-705-001	9627-705-001	1
12	Fuse Holder Assy	9200-001-002	9200-001-002	9200-001-002	
*	Fuse, 1.5Amp	8636-018-001	8636-018-001		
*	Fuse, 2.5Amp			8636-018-004	
13	Label-Fuse, 1.5Amp	8502-716-001	8502-716-001		
13	Label-Fuse, 2.5Amp			8502-716-002	

# WN0600XA-12EN2X-SSKCS-USX

## Schematic/Diagram

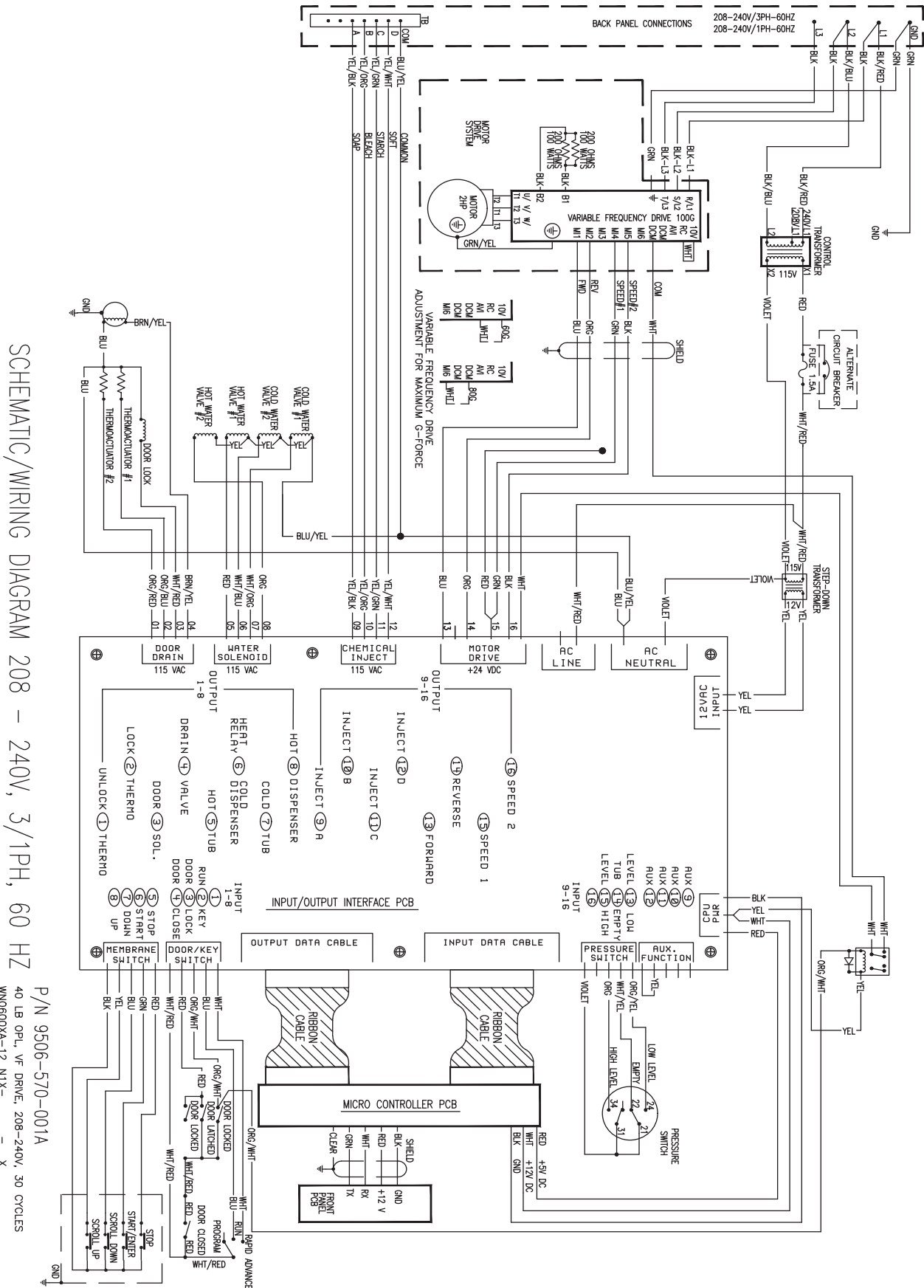

SCHEMATIC/WIRING DIAGRAM 208 - 240V, 3/1PH, 60 HZ

P/N 9506-570-001A  
40 LB OPL. VF. DRIVE, 208-240V, 30 CYCLES  
WN0600XA-12.N1X-...X

# WN0900XA-12EN2X-SSKCS-USX

## Schematic/Diagram

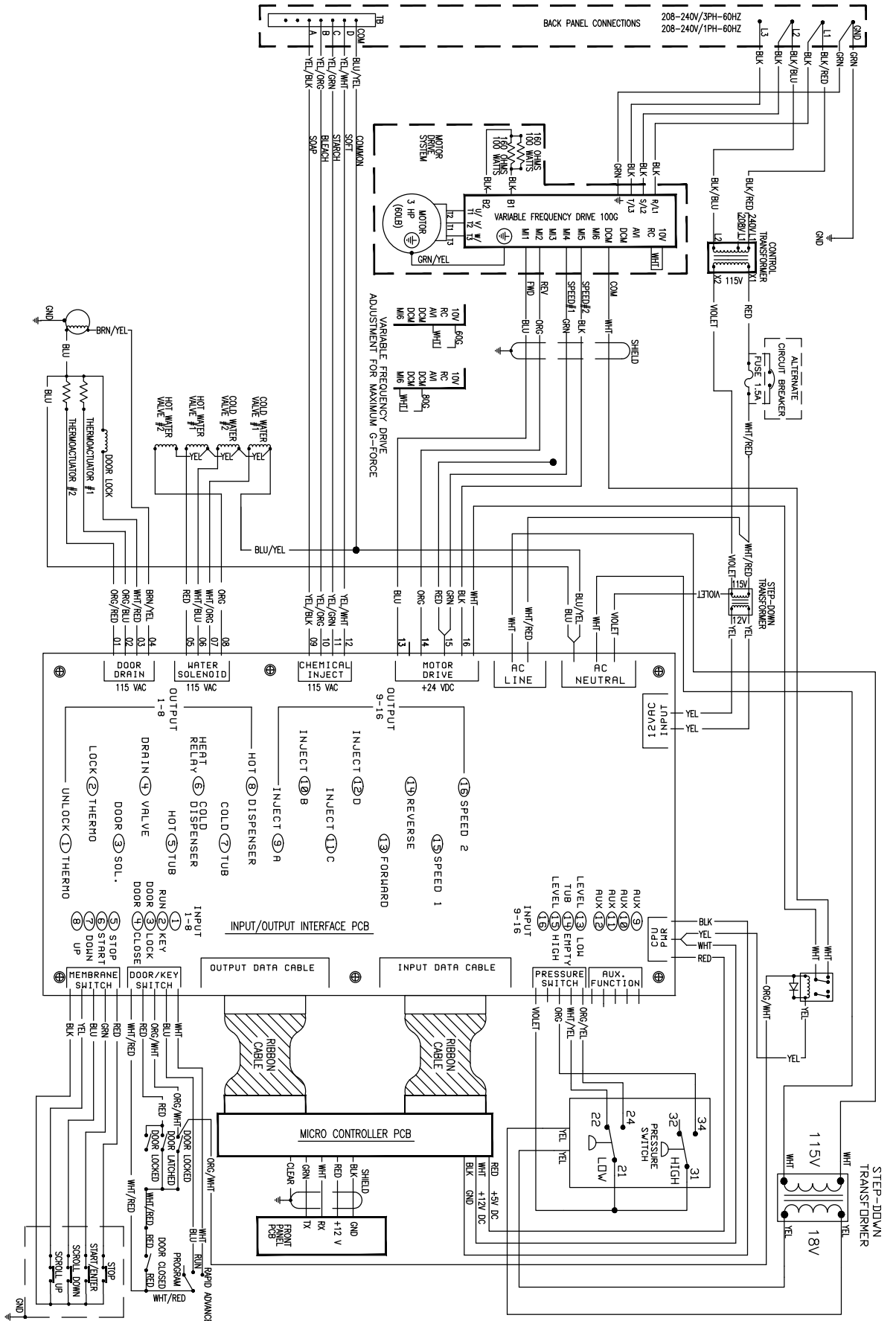

SCHEMATIC/WIRING DIAGRAM 208 - 240V, 3/1PH, 60 HZ

P/N 9506-763-001PR  
 60 LB OPL. VF DRIVE, 208-240V, 30 CYCLES  
 WN0900XA-12-N-X-\_\_\_\_\_X

# WN1200XA-12EN2X-SSKCS-USX

## Schematic/Diagram

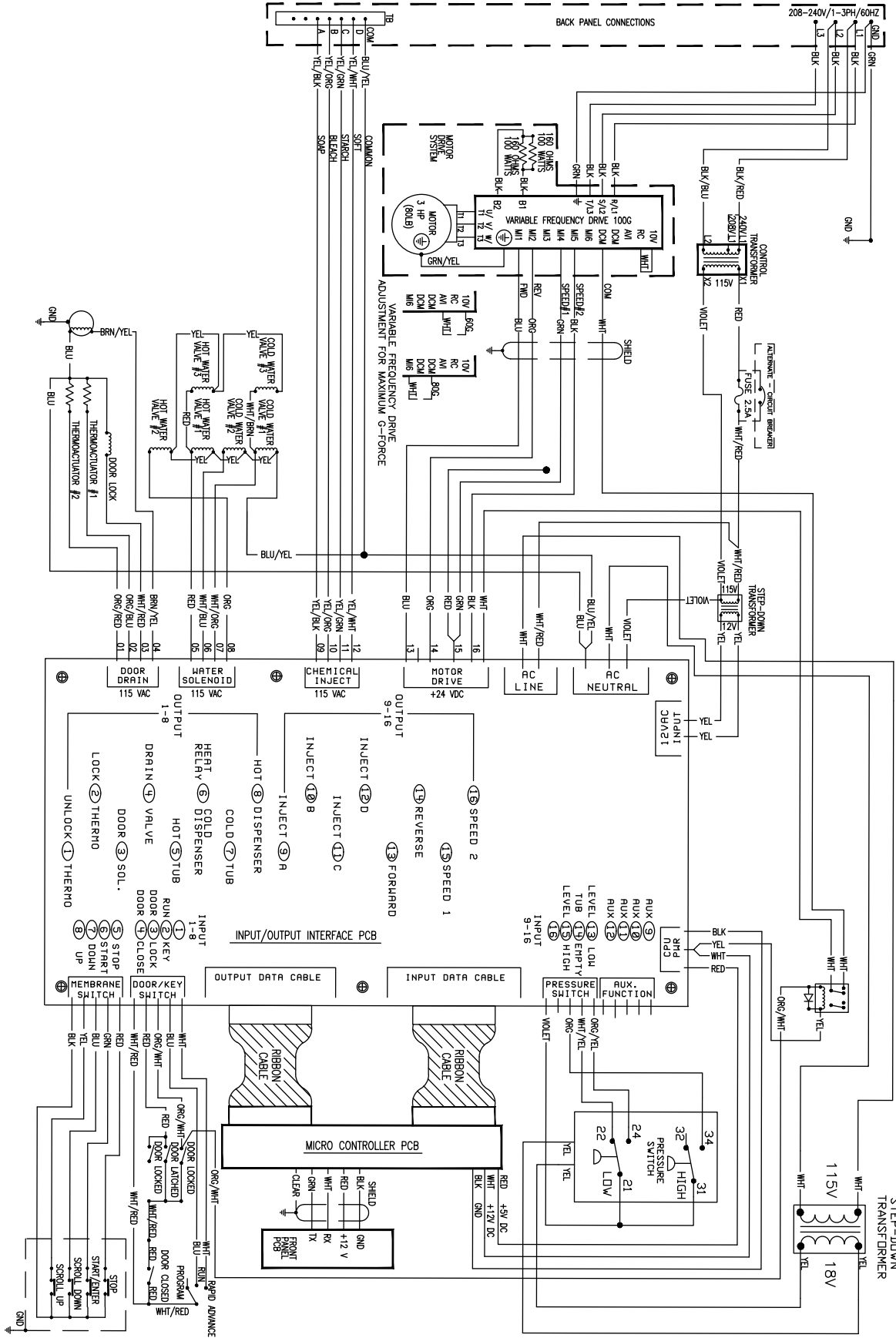

SCHEMATIC/WIRING DIAGRAM 208 - 240V, 3/1PH, 60 HZ  
 P/N 9506-771-001PR  
 80 LB OPL. VF DRIVE, 208-240V, 30 CYCLES  
 WN1200XA-12\_N\_X-\_\_\_\_\_X





---

# **Section 7:**

## Electric Heated Models

---

# Machine Operation

Programmed temperatures will be displayed in CENTIGRADE only. The electric heaters will turn on when low water level has been obtained and actual temperature is less than programmed temperature. While the heaters are engaged the cylinder will pause 3 minutes between each forward/ reverse rotation. The cylinder will resume normal operation when bath temperature is 5 degrees before the programmed temperature is reached. Cycle countdown time display will stop while heaters are engaged. Heaters will maintain temperature throughout heated baths and will engage when bath temperature drops below 3 degrees of programmed temperature. Actual temperature may be displayed by pressing the start and down arrows simultaneously. The temperature light will be on whenever the temperature is being displayed and will continue to be displayed until the start button is pushed again to display time remaining.

Any temperature between 20 degrees and 90 degrees in 5 degree increments is programmable. Any bath that has a programmed spin cycle will go through a short cool down bath before spinning if the actual bath temperature at the time of draining is above 65 degrees . This bath consists of filling tub to low level with WARM water while tumbling and then draining. This will continue until bath temperature is below 65 degrees If machine stop button is pressed momentarily (soak condition) while the heaters are energized, the cylinder will continue with the 3 minute pause between each forward / reverse rotation until the set temperature has been reached. The normal 15 minute pause between each forward/reverse rotation will then take place until the start button is pushed to resume the cycle. Actual bath water temperatures will normally overshoot the set temperature by 1 degree to 3 degree. This is to assure set temperature will be maintained throughout a normal bath time of 10-20 minutes. The heaters will engage if the bath temperature drops below 3 degrees of set temperature.



## Heated Machine Programming

The heated bath is programmed in our water temperature selection portion of our microprocessor. You will program a formula the same way as perviously discussed in this manual except as follows:

When you arrive at temperature selection portion of programming you will see the following choices: EE (tub empty), CC (cold), CH (warm), HH (hot), or any temperature between 20 degrees and 90 degrees in 5 degree increments. Use the up arrow and down arrow pad to set the water temperature desired (Centigrade) and then push the green start button to accept the change and then move to the next programming sequence. Continue with any other cycle changes as previously discussed.

To exit the program mode and accept all changes press the red stop button while any one of the nine bath lights (top row of lights) are lit. The "Select cycle" light should be on. Turn the run/program key back to run position. If the program mode is exited incorrectly, the "Program" light will remain lit and the machine will remain in the program mode until the run/program key is turned back to the program position and the program is exited correctly.

## Features

When a numeric value for temperature is programmed for any bath the water valve selection to fill that bath is chosen as follows:

- 20 degrees - 35 degrees Centigrade Cold valve only will be used
- 40 degrees - 60 degrees Centigrade Cold and Hot Valve will be used
- 65 degrees - 90 degrees Centigrade Hot valve only will be used

The machine will have 6 or 9 heating elements The temperature control and display are operated with a temperature control circuit board on the I/O board, a thermistor sensor in the tub back, and a computer logic board (CPU).

---

The control voltage is 115 vac (60hz) or 24 vac (50hz) to heat relay. Machine available in 208/240 vac 3 phase (60hz), 380/415 vac 3 phase (50hz) ONLY. Optional Temperature control board can be added for non-heated machines to display temperatures and Steam option kit available. Steam valve will operate the same as described throughout except valve will operate in place of heat relay.

## Troubleshooting

If the heater relay does not engage in a heated bath:

Check the calibration switch is set to run position, Check that I/O board jumpers are changed to the level side, Jumper must start closest to level input light and open pin will be towards door input lights.

Check actual water temperature is less than programmed temperature

Check the temperature sensor for open circuit or shorted

Check low level contacts on the pressure switch not closing

Check low level safety relay contacts not closing or bad contacts

Check low level safety relay coil

Check heater relay contacts not closing or bad contacts

Check wiring between temperature board and sensor at all connectors and inspect wires for any damage.

If temperature control board is removed, the programmed temperature value is retained in all baths and the water valves to fill that bath are chosen based on the programmed temperature as described on previous feature page.

## Calibration

The calibration should be checked whenever a temperature sensor has been replaced or if actual water temperature varies significantly from the display. To calibrate the temperature control board go to step #15 of the diagnostic cycle (#31). Actual temperature will be shown in display. On the temperature control board move the cal-run switch to the calibrate position. The factory set calibration temperature of 98 degrees C should show on the display after a few seconds. Now turn the adjusting screw clockwise to increase calibration point and display temperature or counterclockwise to decrease calibration point and display temperature. The display is updated every 5 seconds so make adjustments in very small increments. Be sure to allow ample time for display to respond to updates. If adjustments of higher than 100 degrees C only the last two digits will be displayed.

208-240 vac 3 phase (60hz) 308-415 vac 3 phase (50hz) power is supplied on L-1, L-2, L-3 to the normally open contacts of the heat relay and then to the six heating elements. The elements are wired in star or wye on 50HZ models. A delta configuration is used on 60HZ models. There is a potential 220 volts across each element for both models 60HZ or 50HZ. Control voltage 115 vac (60hz) or 24 vac (50hz) is used to power the heat relay coil and will close the heat relay contacts. The supply voltage will initiate from the I/O board Terminal number #6 (wht/blue wire) through the low-level safety relay contacts and then to the heat relay operating coil when heat is being called for by temperature board. The neutral will be supplied from the (blu/yel) wire connected to AC neutral terminal on the I/O board. The low level safety relay coil will operate when the washer has filled to a level, and gets a signal from the pressure switch. That signal will be 24 VDC and comes from the CPU board and through the pressure switch.

With the low level safety relay contacts now switched and closed, voltage now passes to the heat relay operating coil, and allow main 3 phase voltage across the heating elements. Control voltage 115 vac (60hz) is used to power the steam valve coil. The supply voltage will initiate from the I/O board Terminal number 6 (wht/blue wire) to the heat relay coil when heat is being called for by temperature board. The neutral will be supplied from the (blu/yel) wire connected to AC neutral terminal on the I/O board. The valve gets a signal from the pressure switch. That signal will be 24 VDC and comes from the CPU board and through the pressure switch. With the low level safety relay contacts now switched and closed, voltage now will pass to the heat relay operating coil, and allow main 3 phase voltage across the heating element.

# Electric Heated Chassis & Frame Hardware Group 60hz

Key	Description	T-600	T-900	T-1200	QTY
1	Outer Tub Assy	9930-165-001	9930-158-002	9930-154-002	1
2	Tub & Cylinder Assy	9869-033-002	9869-027-005	9869-022-004	1
*	Bracket Shield Mtg	9029-095-001	9029-095-001	9029-095-001	1
3	Cover - Heater terminals	9074-331-001	9074-330-001	9074-330-001	1
*	Nuts #10-32UNF	8640-413-002	8640-413-002	8640-413-002	3
*	Screw #10Bx1/2	9545-008-026	9545-008-026	9545-008-026	3
*	Screw #10-32x1/2	9545-012-003	9545-012-003	9545-012-003	3
*	Screw 6Bx3/8	9545-031-003	9545-031-003	9545--031-003	2
*	Screw 6ABx3/4	9545-031-010	9545-031-010	9545-031-010	2
*	Screw 6-32x1/4	9545-044-004	9545-044-004	9545-044-004	3
4	Hose, Tub to Drain	9242-456-002	9242-459-001	9242-459-001	1
*	Bracket Shield R H	9029-193-001		9029-095-001	1
*	Screw #8-32x3/4"	9545-010-001	9545-010-001	9545-010-001	3

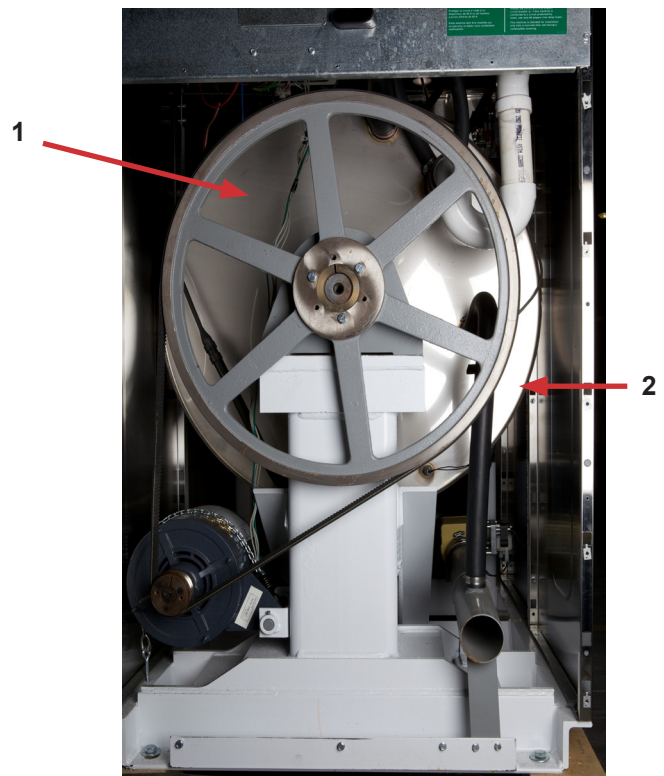
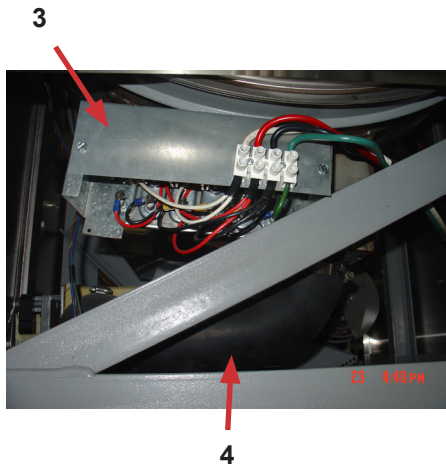

## Electric Heated Terminal Block Group

Key	Description	T-600	T-900	T-1200	QTY
*	Terminal Block, power	9897-033-002	9897-033-002	9897-033-002	1
*	Terminal Marker Strip	9558-025-001	9558-025-001	9558-025-001	1
*	Screw	9545-031-010	9545-031-010	9545-031-010	2
*	Terminal Block, Injector	9897-032-002	9897-032-002	9897-032-002	1
*	Terminal Marker Strip	9558-028-001	9558-028-001	9558-028-001	1
*	Screw	9545-053-002	9545-053-002	9545-053-002	2

## Electric Heated Labels Group

Key	Description	T-600	T-900	T-1200	QTY
1	Label, Warning Door Opening	8502-757-001	8502-757-001	8502-757-001	1
*	Label, High Voltage	8502-614-004	8502-614-004	8502-614-004	3
2	Label, Connections- Injector	8502-647-002	8502-647-002	8502-647-002	1
*	Label, Connections- Electrical	8502-649-001	8502-649-001	8502-649-001	1
*	Label, Fusing & Installation	8502-619-006	8502-619-006	8502-619-007	1
*	Label, Warning	8502-639-001	8502-639-001	8502-639-001	1
*	Label, Insturction Dispenser	8502-650-001	8502-650-001	8502-650-001	1
*	Label, Installer Instructions	8502-653-001	8502-653-001	8502-653-001	1
*	Label, Injector assembly	8502-666-001	8502-666-001	8502-666-001	1
	Instructions Chemical hose installation	8507-268-001	8507-268-001	8507-268-001	1
	Instructions Spin Direction	8507-274-001	8507-274-001	8507-274-001	1
	Schematic/Wirng Diagram	9506-571-001	9506-573-001	9506-576-001	1
	Owners Booket	8514-241-001	8514-244-001	8514-246-001	1

## Electric Heated Wiring Harness Group

Key	Description	T-600	T-900	T-1200	QTY
	Wiring Harness, VFD Control Shield	9627-810-001	9627-810-001	9627-701-001	1
	Wiring Harness, Pressure Switch	9627-704-001	9627-704-001	9627-704-001	1
	Wiring Harness Door /Lock -Keylock	9627-837-001	9627-892-001	9627-892-001	1
	Wiring Harness CPU to Display	9627-705-001	9627-705-001	9627-705-001	1
	Wiring Harness Membrane Switch	9627-700-001	9627-700-001	9627-700-001	1
	Wiring CPU to I/O board	9627-706-001	9627-706-001	9627-706-001	1
*	Wiring Harness, Power Term Blk	9627-748-001	9627-748-002	9627-876-001	1
*	Wiring Harness, Main Heater Assembly	9627-755-001	9627-755-001	9627-755-001	1
*	Wiring Harness, Temp Sensor	9627-762-001	9627-762-001	9627-762-001	1
	VFD to Motor Drive	9627-742-001	9627-742-001	9627-742-001	1
	Wiring Harness, Trough, 115VAC	9627-697-001	9627-697-001	9627-697-001	1
	Wiring Harness, 115VAC	9627-698-001	9627-698-001	9627-698-001	1
	Wiring Harness Control to VFD	9627-710-001	9627-710-001	9627-710-001	1
	Clamp, Cable- 3/16 Dia	8654-125-005	8654-125-005	8654-125-005	1

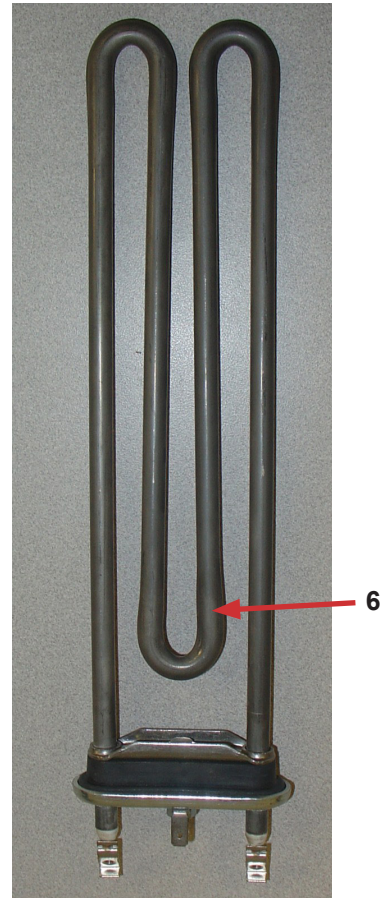
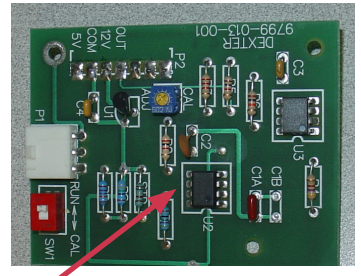
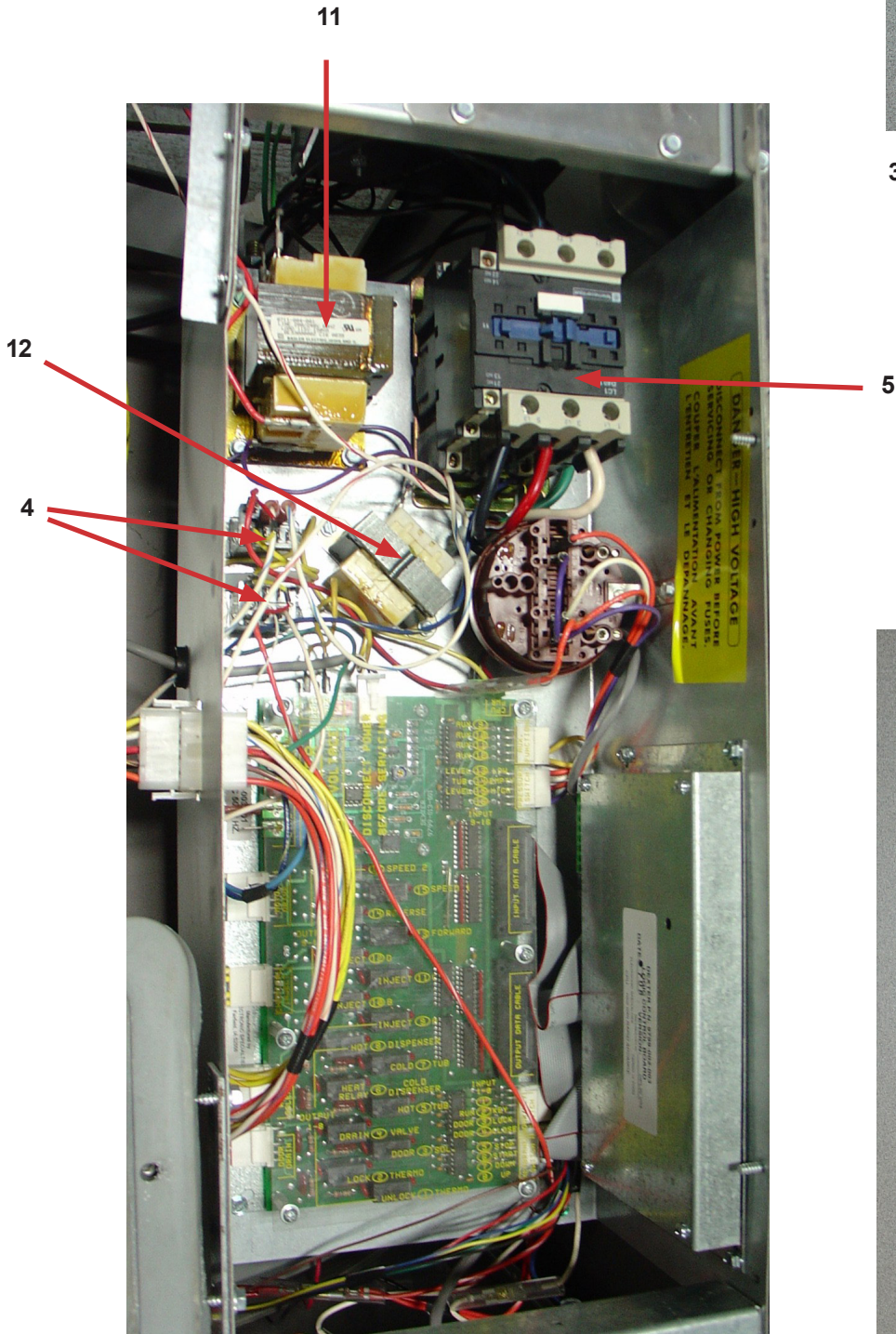

# Heated Washer Electrical Components

Key	Description	T-600	T-900	T-1200	QTY
1	Control assembly Trough	9857-214-005	9857-216-009	9857-217-005	1
2	Sensor Assembly	9501-005-002	9501-005-002	9501-005-002	1
3	PC Board Assembly -Temperature Control	9799-013-001	9799-013-001	9799-013-001	1
*	Screw	9545-044-004	9545-044-004	9545-044-004	3
*	Terminal - Lug	8652-134-002	8652-134-002	8652-134-002	1
*	Terminal Block Assy Power	9897-033-002	9897-033-002	9897-033-002	1
4	Run Relay ( R-1 ) and level relay	5192-285-003	5192-285-003	5192-285-003	2
*	Diode Ass'y	8220-001-442	8220-001-442	8220-001-442	2
*	Wire Assembly-WHT/BLU, 28"	8220-063-003	8220-063-003	8220-063-003	1
*	Wire Assembly-WHT/BLU, 10"	8220-078-006	8220-078-006	8220-078-006	1
*	Wire Assy -Jumper, YEL	8220-083-001	8220-083-001	8220-083-001	1
5	Heat Relay 60 amp	5192-291-001	5192-291-001	5192-291-001	1
*	Wire Assembly-BLU/YEL, 12"	8220-064-001	8220-064-001	8220-064-001	1
6	Heater Element	9870-087-001			6
6	Heater Element		9870-087-001	9870-087-001	9
7	Wire Assy -Jumper, BLK 4-8	8220-085-001	8220-085-001	8220-085-001	3
8	Wire Assy -Jumper, RED 6-8	8220-085-002	8220-085-002	8220-085-002	3
9	Wire Assy -Jumper, WHT 4-8	8220-085-003	8220-085-003	8220-085-003	3
*	Strip, Terminal Marker ( Power )	9558-025-001	9558-025-001	9558-025-001	1
*	Strip, Terminal Marker Injector (120 volts signals )	9558-028-001	9558-028-001	9558-028-001	1
*	Screw, Mtg	9545-031-010	9545-031-010	9545-031-010	
10	Wire Assy- Green 4"	8220-001-484			5
10	Wire Assy- Green 4"		8220-001-484	8220-001-484	8
*	Wire Assy-Green 11"	8220-064-055	8220-064-055	8220-064-055	1
*	Wire Assy- RED 9"	8220-063-002	8220-063-002	8220-063-002	1
11	Transformer, Control (Primary Voltage to 115 volts)	8711-004-001	8711-004-001	8711-004-001	1
12	Transformer, Secondary (120v to 12vac)	8711-003-001	8711-003-001	8711-003-001	

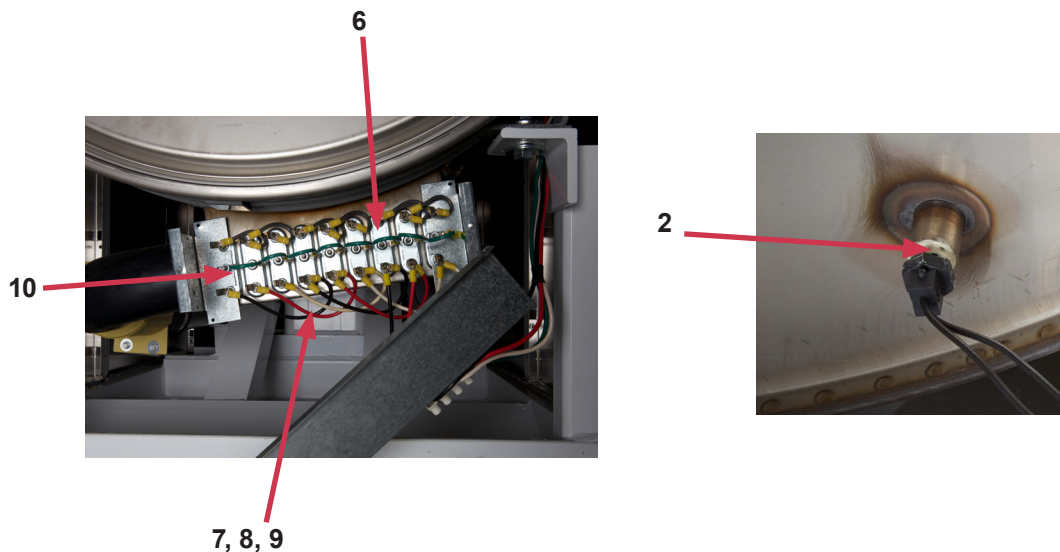



# WN0600EA - 13XN

SCHEMATIC/WIRING DIAGRAM 208-240V/3PH, 60 HZ

40# COMPUTER WASHER W/HEAT OPTION

9345-909-001J

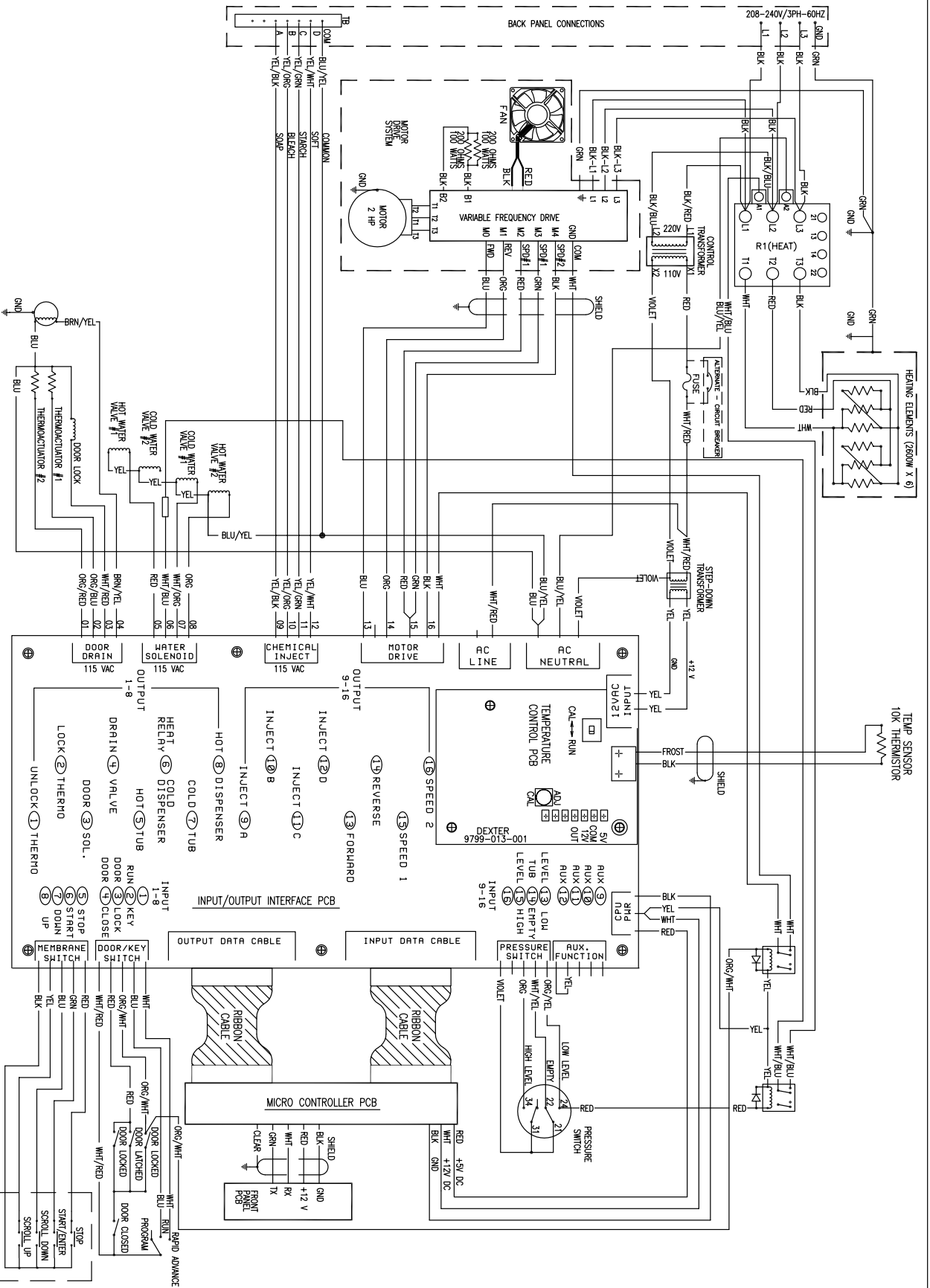

# WN900EA-13XN

SCHEMATIC/WIRING DIAGRAM 208 - 240V, 3PH, 60 HZ

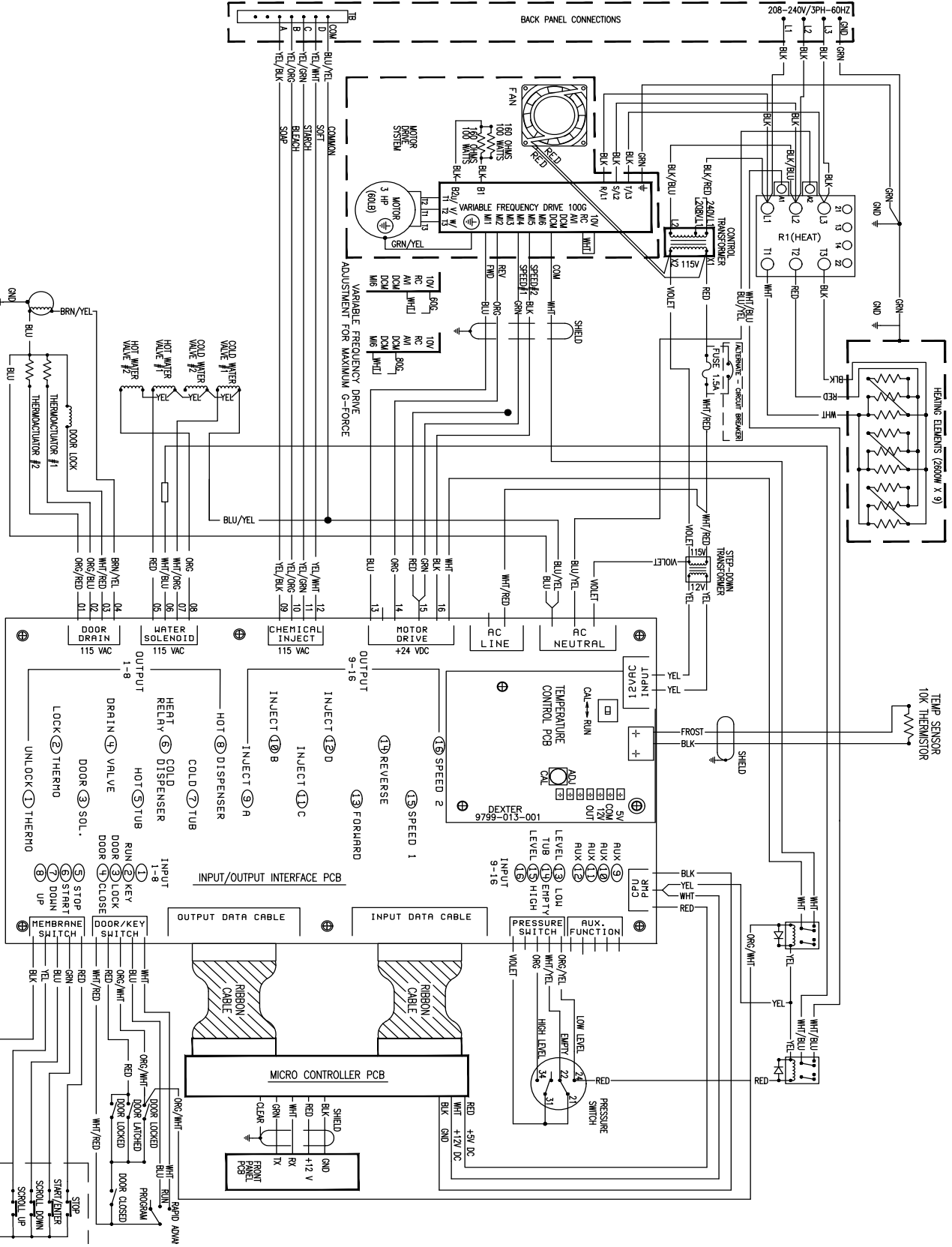

60 LB OPL. VF DRIVE, 208-240V, 30 CYCLES, ELECTRIC HEAT  
WN900EA-13-N1X-\_\_\_\_\_X

P/N 9506-573-001A

# WN1200EA-13XN

WIRING SCHEMATIC 208-240V/3PH,60 HZ 9506-331-001G 75# OR 80# COMPUTER WASHER W/HEAT OPTION

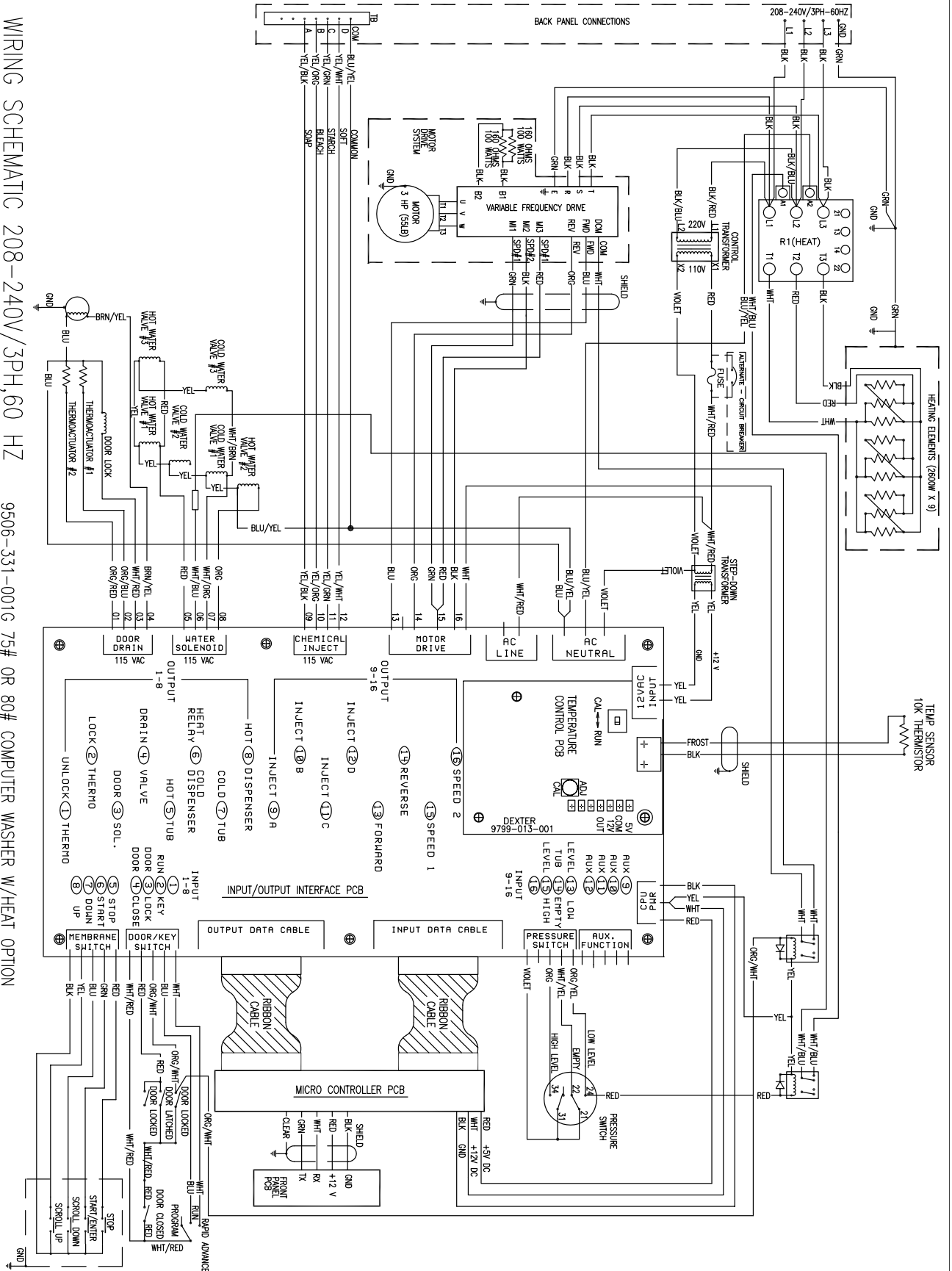



---

# **Section 8:**

Steam Heated

Valve Kit

# Steam Injection Kit for OPL Computer Washers (Only to be installed on Heated Tub Models Design)

Parts for Kit 9732-259-001, -002

KEY	Part Description	T600	T900	T1200	Qty
	Valve-steam , 3/8 pilot (60 Hz only)	9379-189-001	9379-189-001	9379-189-001	1
	Valve-steam , 3/8 pilot (50 Hz only)	9379-189-002	9379-189-002	9379-189-002	1
	Hose assemblyBsteam, 3/8	9990-034-002	9990-034-002	9990-034-002	1
	Tube assy-baffle, steam	9915-123-001	9915-123-001	9915-123-001	1
	PCB assy-temp control	9799-013-001	9799-013-001	9799-013-001	1
	Sensor assy-thermistor,10k	9501-005-002	9501-005-002	9501-005-002	1
	Wiring harness-temp control	9627-762-001	9627-762-001	9627-762-001	1
	Bushing-reducer, hex	8615-104-043	8615-104-043	8615-104-043	1
	Bracket-steam valve	9029-125-001	9029-125-001	9029-125-001	1
	Clamp-st st worm, 1 3/4	8654-117-016	8654-117-016	8654-117-016	1
	Screw-hx hd, #10 AB x 1/2	9545-008-026	9545-008-026	9545-008-026	2
	screw-pan hd, #6-32	9545-044-004	9545-044-004	9545-044-004	3
	Schematic / Diagram	9506-343-001	9506-344-001	9506-345-001	1

---

## To Install:

- 1) Remove electrical power from the machine.
- 2) Remove top panel, rear panel, and lower service door.
- 3) Remove the 2" pipe plugs from the couplings in the tub back (Fig. 1) and the sump (Fig. 2).
- 4) Using Teflon tape on the threads, screw the reducer bushing into the coupling at the bottom of the tub back. (Fig. 3)
- 5) Seal the temperature sensor threads with Teflon tape and install into the reducer bushing. (Fig. 3)
- 6) Plug in one end of the sensor wiring harness to the temperature sensor. (Fig. 3)
- 7) In the control box, remove the I/O board cover and plug the temperature control board into the appropriate socket in the I/O board. Attach the temperature control board to the standoffs in the I/O board with the three screws provided. (Fig. 4)
- 8) Replace the I/O board cover and attach the remaining end of the temperature sensor wiring harness into the temperature control board socket. Route the harness away from all moving parts and wire tie as needed. (Fig. 4)
- 9) Seal threads of steam baffle assembly with Teflon tape and install it into the coupling on the side of the sump. Align the holes in the baffle to run from the front to the rear of the sump. (Fig. 5)
- 10) Unscrew the worm clamp provided and place it around the body of the steam valve just below the steam valve solenoid housing. Reattach the clamp ends and attach the steam valve to the steam valve bracket by sliding the worm clamp over the notches in the bracket and tightening the worm clamp screw. (Fig. 6)
- 11) Seal threads of steam hose ends and attach the end without the union to the outlet side of the steam valve. (Fig. 6)
- 12) Attach the steam valve bracket to the side panel flange at the rear of the washer, just below the rear channel with the #10 sheet metal screws provided. (Fig. 6)
- 13) Screw the coupling end of the steam hose into the threaded end of the steam baffle. (Fig. 7)
- 14) Attach the green ground wire from the steam valve solenoid to the ground lug in the wiring connection area at the rear of the machine.
- 15) Attach one control lead of the steam valve solenoid to the common connection of the soap injection terminal block.
- 16) Disconnect the wht/blu signal wire from the cold-flush water valve solenoid (output #6 on the I/O board) and connect it to the remaining control lead for the steam valve solenoid.  
(NOTE: cold water flush to soap box in final rinse is eliminated)
- 17) Attach user-supplied steam pipe to the inlet side of the steam valve.  
(NOTE: manual shut off valve and union coupling connection recommended for easier servicing)
- 18) Cut relief notch for steam pipe in corner of back panel before replacing.

---

# Optional Steam Valve Kit

## Features

When the numeric temperature value is programmed for any bath, the water valve selection to fill that bath is chosen as follows:

20 degrees - 35 degrees Centigrade	Cold valve only will be used
40 degrees - 60 degrees Centigrade	Cold and Hot valve will be used
65 degrees - 90 degrees Centigrade	Hot valve only will be used

The temperature control and display are controlled using the temperature control circuit board on the I/O board, the thermistor sensor in the tub back, and the computer logic board (CPU). The control voltage is 115 volts (60hz).

## Operating Parameters

The programmed temperature will be displayed in Centigrade only.

The steam valve will be activated when the low water level has been reached and the actual water temperature is less than the programmed temperature.

While the steam valve is engaged, the cylinder will pause 3 minutes between each forward/reverse rotation. The cylinder will resume normal operation once the water bath temperature is within 5 degrees of the programmed temperature.

Cycle countdown time display will stop while valve is engaged.

During the cycle, if the water bath temperature drops 3 degrees below the programmed temperature, the steam valve will engage to maintain the water temperature.

The actual water temperature will display by pressing the Start and Down arrows simultaneously. The temperature light will be on whenever the temperature is being displayed. The temperature light will continue to be displayed until the Start button is pushed again, changing the display over to time remaining.

The control can be programmed to maintain any temperature between 20 degrees and 90 degrees. The programming is in 5 degree increments.

Any bath that has a programmed spin cycle will go through a short cool down bath before spinning if the actual bath temperature at the time of draining is above 65 degrees . This bath consists of filling tub to low level with WARM water while tumbling and then draining. This will continue until bath temperature is below 65 degrees.



---

If the Stop button is pressed momentarily (soak condition) while the heaters are energized, the cylinder will continue with a 3 minute pause between each forward/reverse rotation until the set temperature has been reached. The normal 15 minute pause between each forward/reverse rotation will then take place until the Start button is pushed to resume the cycle.

To assure that the programmed temperature will be maintained throughout the entire bath, the water temperatures will normally overshoot the set temperature by 1 to 3 degrees. The steam valve will engage if the bath temperature drops more than 3 degrees below the set temperature.

## Programming Differences

The heated water bath is programmed in the water temperature selection portion of the microprocessor.

At temperature selection portion of programming there will be the following choices:

EE (tub empty), CC (cold), CH (warm), HH (hot), or any temperature between 20 degrees and 90 degrees in 5 degrees increments.

Use the Up arrow and Down arrow pad to set the water temperature desired (Centigrade) and then push the green Start button to accept the change and then move to the next programming sequence.

Continue with any other cycle changes as previously discussed.

To exit the program mode and accept all changes press the red Stop button while any one of the nine bath lights (top row of lights) are lit. The "Select Cycle" light should be on.

Turn the run/program key back to run position. If the program mode is exited incorrectly, the "Program" light will remain lit and the machine will remain in the program mode until the run/program key is turned back to the program position and the program is exited correctly.

## Steam Calibration

The calibration should be checked whenever a temperature sensor has been replaced or if actual water temperature varies significantly from the display. To calibrate the temperature control board go to step # 15 of the diagnostic cycle (#31). Actual temperature will be shown in display.

On the temperature control board move the cal-run switch to the calibrate position. The factory set calibration temperature of 98 degrees C should show on the display after a few seconds. Now turn the adjusting screw clockwise to increase calibration point and display temperature or counterclockwise to decrease calibration point and display temperature. The display is updated every 5 seconds so make adjustments in very small increments.

Be sure to allow ample time for display to respond to updates. If adjustments of higher than 100 degrees C only the last two digits will be displayed.

---

## Steam Valve Troubleshooting

If the valve does not engage in a heated bath:

- 1) Check the calibration switch is set to run position.
- 2) Check that I/O board jumpers are changed to the level side, Jumper must start closest to level input light and open pin will be towards door input lights.
- 3) Check actual water temperature is less than programmed temperature
- 4) Check the temperature sensor for open circuit or shorted
- 5) Check low level contacts on the pressure switch not closing
- 6) Check steam valve coil
- 7) Check the wiring between temperature board and sensor at all connectors and inspect wires for any damage.

If the temperature control board is removed, the programmed temperature values are retained in all baths and the water valves to fill that bath are chosen based on the programmed temperature.

## Steam Heated Washer Schematics

Control voltage (115VAC / 60hz) is used to power the steam valve coil. The supply voltage will initiate from the I/O board Terminal number #6 (wht/blue wire) to the steam valve coil when heat is being called for by temperature board. The neutral will be supplied from the (blu/yel) wire connected to AC neutral terminal on the I/O board. The valve will get a signal when the pressure switch reaches low level. 115 Vac will operate steam valve until programmed temperature is reached.

Please remember you will lose a cold water dispenser flush signal as this is now the operating signal track on the I/O PCB board . It is marked on the lettering shield on the top of the I/O board.

# WN0600SA-12XN

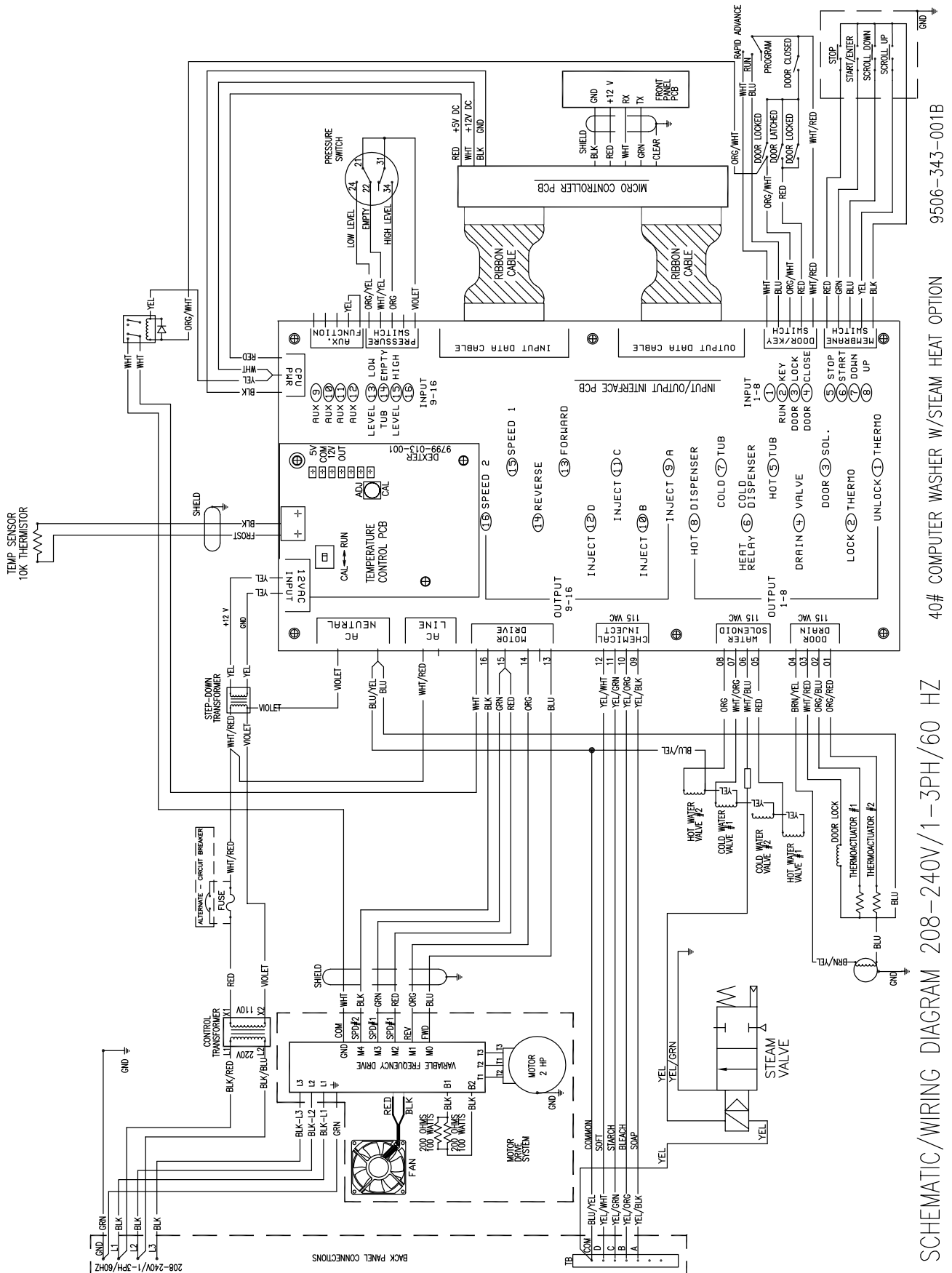

SCHEMATIC/WIRING DIAGRAM 208-240V/1-3PH/60 HZ 40# COMPUTER WASHER W/STEAM HEAT OPTION 9506-343-001B

# WN0900SA-12XN

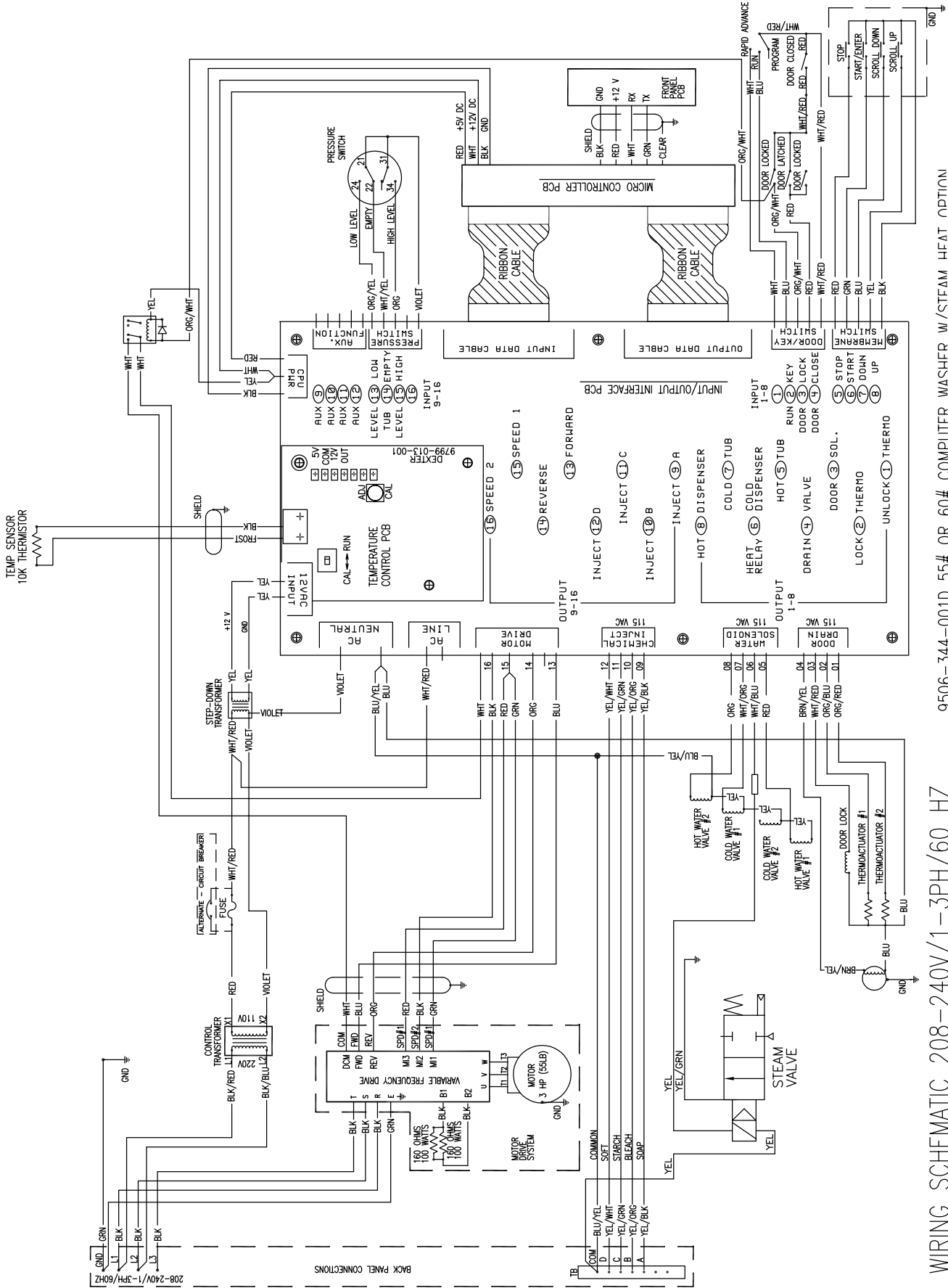

WIRING SCHEMATIC 208-240V/1-3PH/60 HZ 9.506-344-001D 5.5# OR 60# COMPIUTER WASHER W/STEAM HEAT OPTION

# WN1200SA-12XN

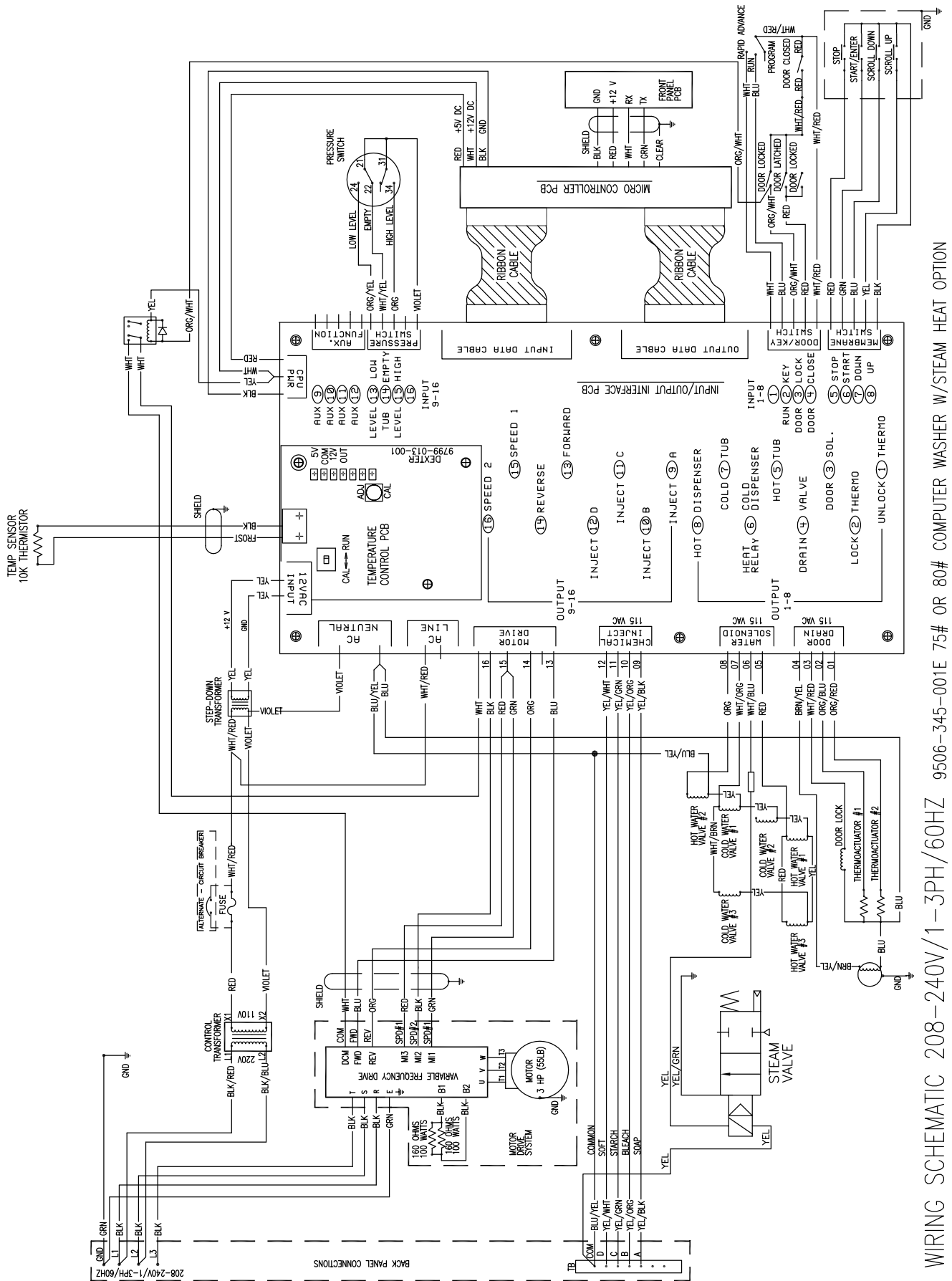

WIRING SCHEMATIC 208-240V/1-3PH/60HZ 9506-345-001E 75# OR 80# COMPUTER WASHER W/STEAM HEAT OPTION

---

# Section 9:

## 50 Hz Models

Parts in this section used only in these models. All other parts are same as standard 60 Hz pages.

	Model	hz	Phase	Voltage	Heat Option	G's
9999-662-002	Wn0600xa-39xn2x-sskcs-vrx	50	1ph	230-240v		100
9999-662-004	Wn0600ea-68xn2x-sskcs-vrx	50	3ph	400v	Heated Electric	100
9999-662-005	Wn0600ea-59cn2x-sskcs-vrx	50	1ph	230v		100
9999-665-002	Wn0900xa-39xn2x-sskcs-vrx	50	1ph	230-240v		100
9999-665-006	Wn0900ea-58cn2x-sskcs-vrx	50	3ph	400v	Heated Electric	100
9999-665-004	Wn0900ea-68xn2x-sskcs-vrx	50	3ph	400v	Heated Electric	100
9999-669-002	Wn1200xa-39xn2x-sskcs-vrx	50	1ph	230-240v		100
9999-669-004	Wn1200ea-68xn2x-sskcs-vrx	50	3ph	400v	Heated Electric	100

# Transformer, Electrical, & Filter and - 50 HZ

Key	Component	T-600	T-900	T-1200	QTY
1	EMI Filter, 1Ph, 24 Amp	9183-045-001	9183-045-001	9183-045-001	1
*	Wire Assembly Black / Red	8220-061-003			1
*	Wire Assembly Black / Blue	8220-061-004			1
2	EMI Filter (Ferrite Core)	9183-033-001	9183-033-001	9183-033-001	2
3	EMI Line Filter (EP)	9133-032-004	9133-032-001	9133-032-001	1
	Filter Mounting Plate Assembly			9552-758-001	
*	Wire Assembly, RED	8220-065-024	8220-065-024	8220-065-030	1
*	Wire Assembly, BLU	8220-065-018	8220-065-018	8220-065-031	1
4	Transformer-Control	8711-008-001	8711-008-001	8711-008-001	1
*	Instructions, Transformer Connections	8507-230-003	8507-230-003	8507-230-003	1
*	Wire Assembly, RED	8220-065-011	8220-065-011	8220-065-030	1
5	Circuit Breaker	5198-211-002	5198-211-002	5198-211-002	1
*	Wire Assembly, VIO 8"	8220-065-013	8220-065-013	8220-065-013	1
*	Wire Assembly, YEL 8"	8220-065-012	8220-065-012	8220-065-012	1
6	PCB Assembly, I/O interface	9799-003-003	9799-003-003	9799-003-003	1
*	Wire Assembly, Jumper, YEL	8220-123-001			1
*	Bracket Drive Mounting	9985-178-001	9029-184-001		1
*	Owner's Booklet	8514-241-002	8514-244-002	8514-246-002	1

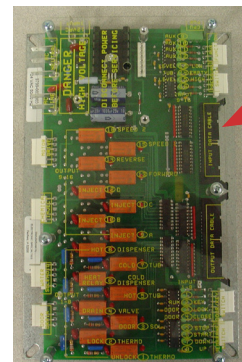
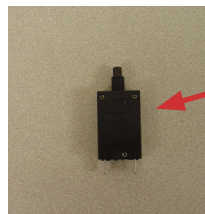
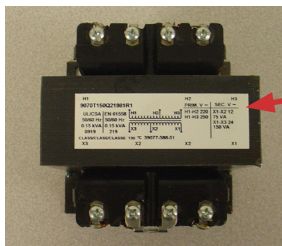
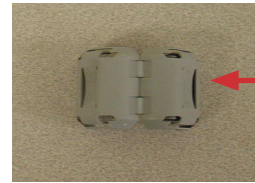
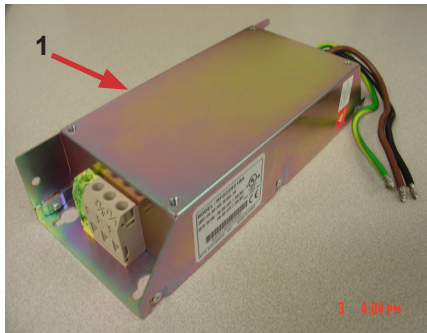

# Water Valve, Drain Valve, 50hz models

	Description	T-600	T-900	T1200	QTY
1	Water Valve	9379-183-013	9379-183-013	9379-183-013	2
3	Drain Valve 3" inch	9379-202-002	9379-202-002	9379-202-002	1
4	Water Valve , Mueller single			9379-194-003	2
5	Solenoid 24VAC/50Hz	9536-082-001	9536-082-001	9536-082-001	1
6	Thermoacuator 24 VAC/50Hz	9586-001-003	9586-001-003	9586-001-003	2
*	Screw #10-32 TT X1/2	9545-008-027	9545-008-027	9545-008-027	3
*	Screw #8-32 X3/8	9545-010-006	9545-010-006	9545-010-006	2
*	Screw Hex 8B X1/4	9545-045-001	9545-045-001		4
*	Terminal Strip Marker, Inject	9558-028-002	9558-028-002	9558-028-002	1
*	Wiring Harness, Power Terminal Block	9627-865-002	9627-747-003	9627-747-002	1

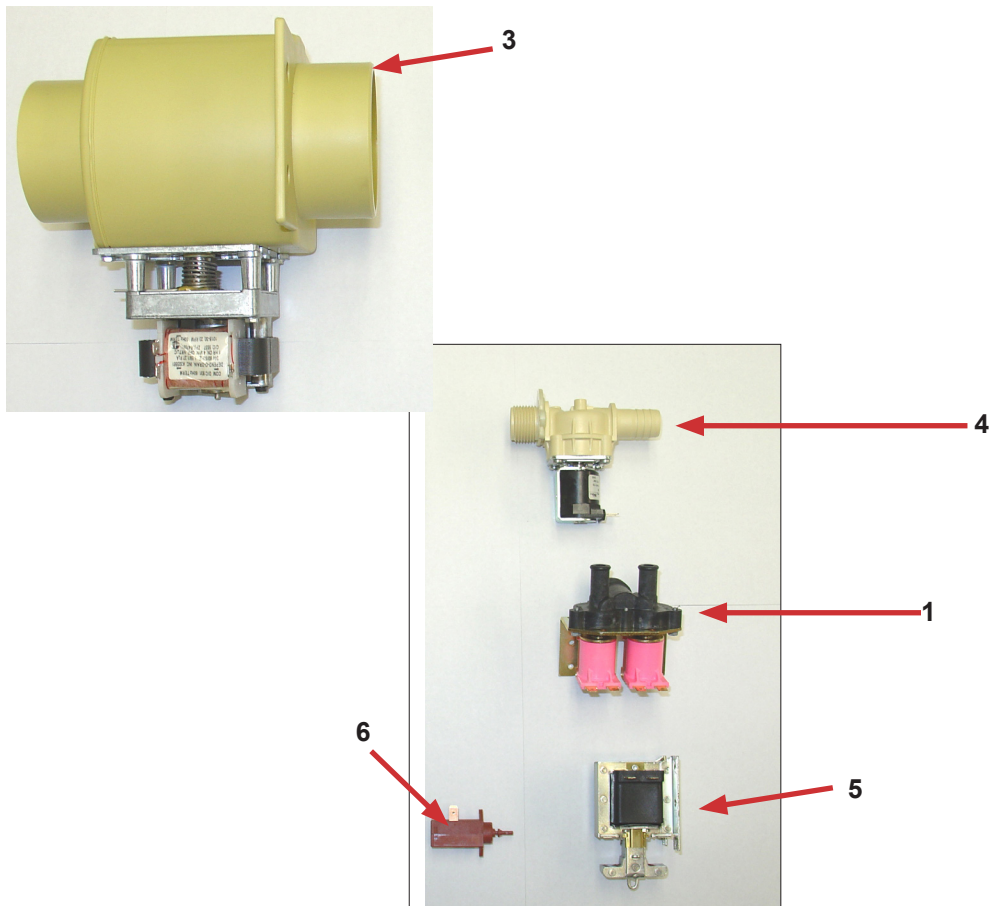



# All Models 50 Hz Gear Motor Door Lock Assembly

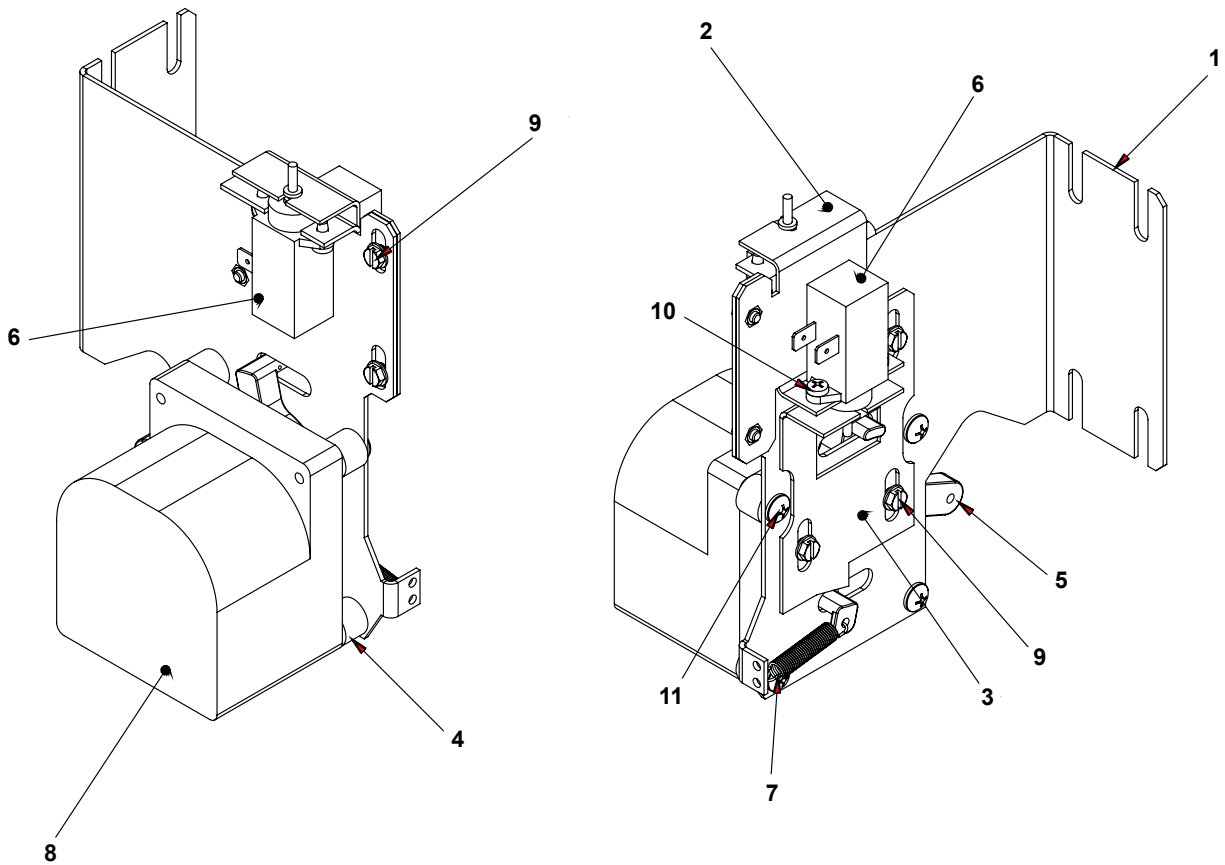

Key	Description	T-600	T-900	T-1200	QTY
11	Screw Pnhdcr, 10-32 UNFx0 .75	9545-012-029	9545-012-029	9545-012-029	4
10	Cross Recessed PAn Hd Tapping screw	9545-031-011	9545-031-011	9545-031-011	4
9	Screw -Hxwshrhdslsems, 6-32 x 3/16	9545-044-003	9545-044-003	9545-044-003	6
8	Motor & Gear Assembly 24v	9914-137-014	9914-137-014	9914-137-014	1
7	Spring - Extension	9534-350-001	9534-350-001	9534-350-001	1
6	Thermoactuator - Door Lock Relay 24v	9586-001-003	9586-001-003	9586-001-003	2
5	Arm - Door Lock	9001-063-001	9001-063-001	9001-063-001	1
4	Spacer, Plastic	9538-157-021	9538-157-021	9538-157-021	4
3	Bracket Slide Lock	9029-204-001	9029-204-001	9029-204-001	1
2	Bracket Assy, Slide - Unlock	9985-189-001	9985-189-001	9985-189-001	1
1	Bracket Assy, Slide Lock Actuator	9985-190-001	9985-190-001	9985-190-001	1
*	Rod, Door Lock	9497-225-010	9497-225-013	9497-225-015	1

# Misc Parts -50 HZ. Models

KEY	Part Description	T-600	T-900	T-1200	Qty
*	Nuts #10-32UNF,2B			8640-413-002	7
1	Transformer, Control	8711-008-001	8711-008-001	8711-008-001	1
2	PCB Assembly, I/O interface	9799-003-003	9799-003-003	9799-003-003	1
*	Wiringlabel-Schematic	9506-760-001	9506-764-001	9506-772-001	1
*	Stripe Terminal Marker (injector)24v	9558-028-002	9558-028-002	9558-028-002	1
*	Terminal Lug Solderless	8652-134-002	8652-134-002	8652-134-002	1
*	Angle support ,Trough		9003-229-001	9003-308-001	1
*	Contol Trough only	9839-016-001	9839-016-001	9839-016-001	1
*	Complete Controlsassembly -Trough 50hz	9857-214-004	9857-216-007	9857-217-004	1
*	Label-Fusing & Installation	8502-619-004	8502-619-003	8502-619-003	1
*	Screw #6Tx5/16		9545-031-011	9545-031-011	2
*	Tub Assembly	9930-164-001	9930-158-002	9930-1503001	1
	Tub & Cylinder Assembly	9869-033-001	9869-027-004	9869-022-003	1

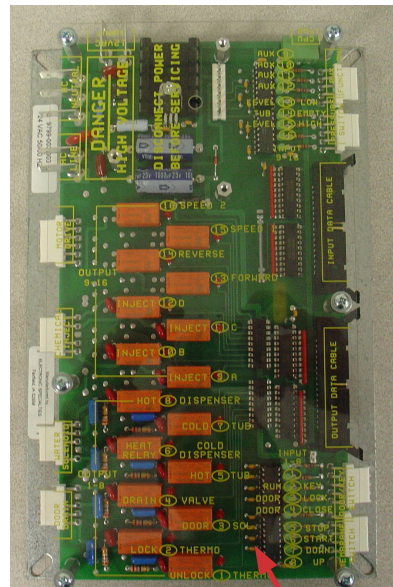
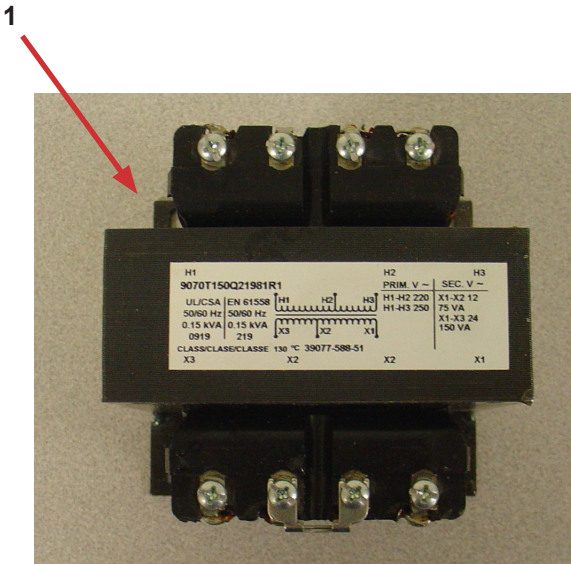

# WN0600XA-39XN

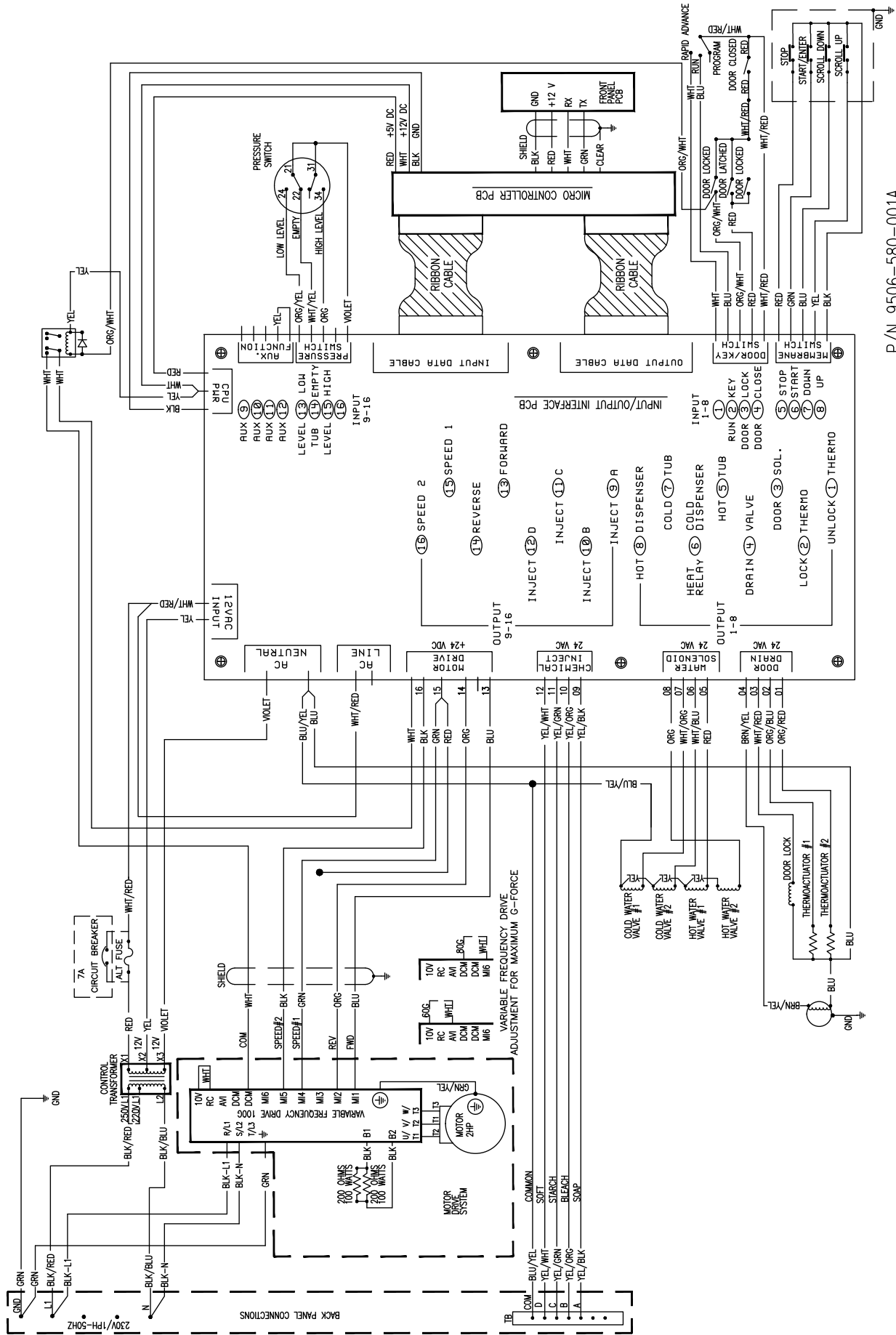

P/N 9506-580-001A  
40 LB OPL, VF DRIVE, 230V, 30 CYCLES, 24V ACTUATORS  
WN0600XA-39XN1X-\_\_\_\_\_X

SCHEMATIC/WIRING DIAGRAM 230V, 1PH, 50 HZ

# WN0900XA-39XN

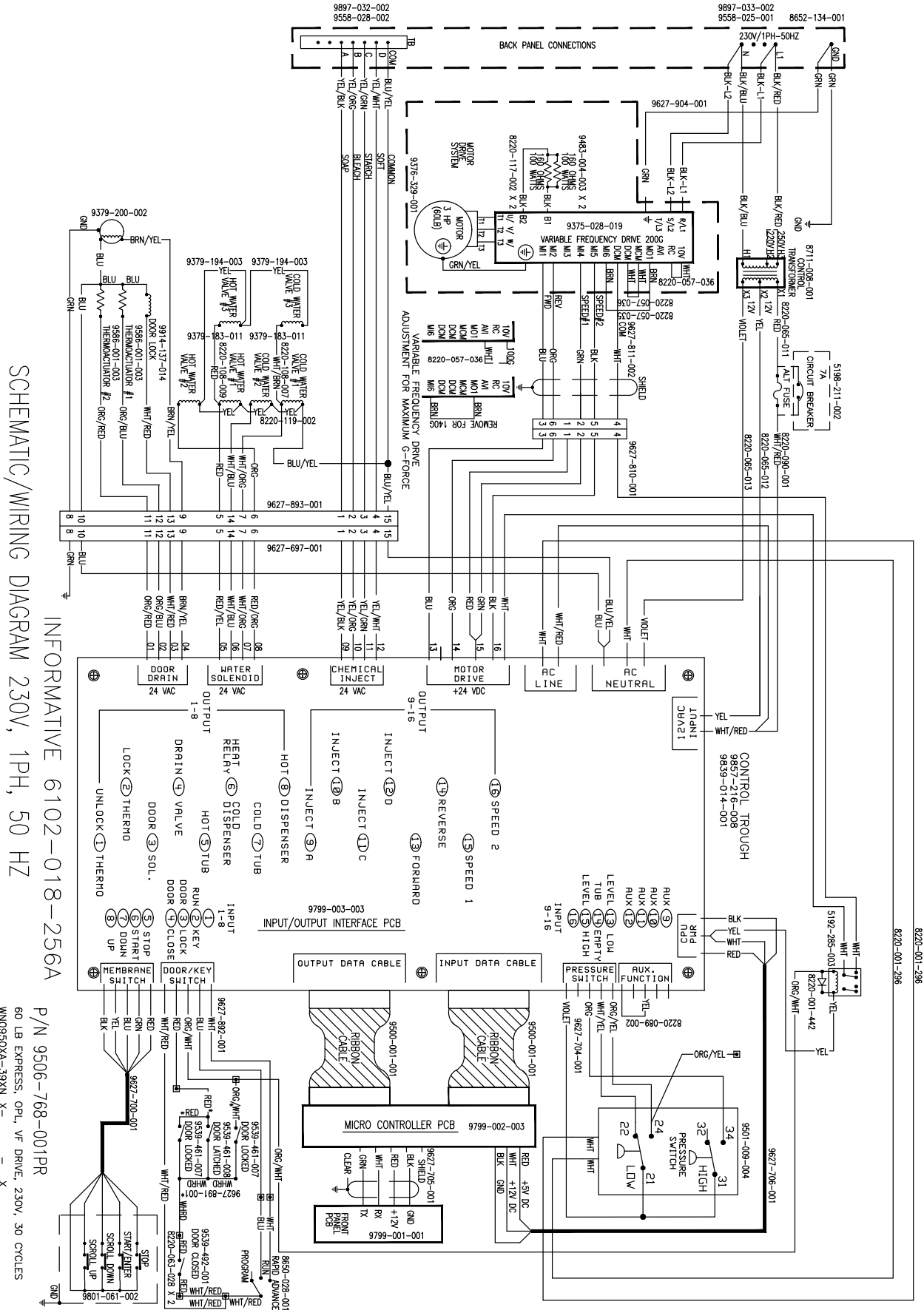

# WN1200XA-39XN

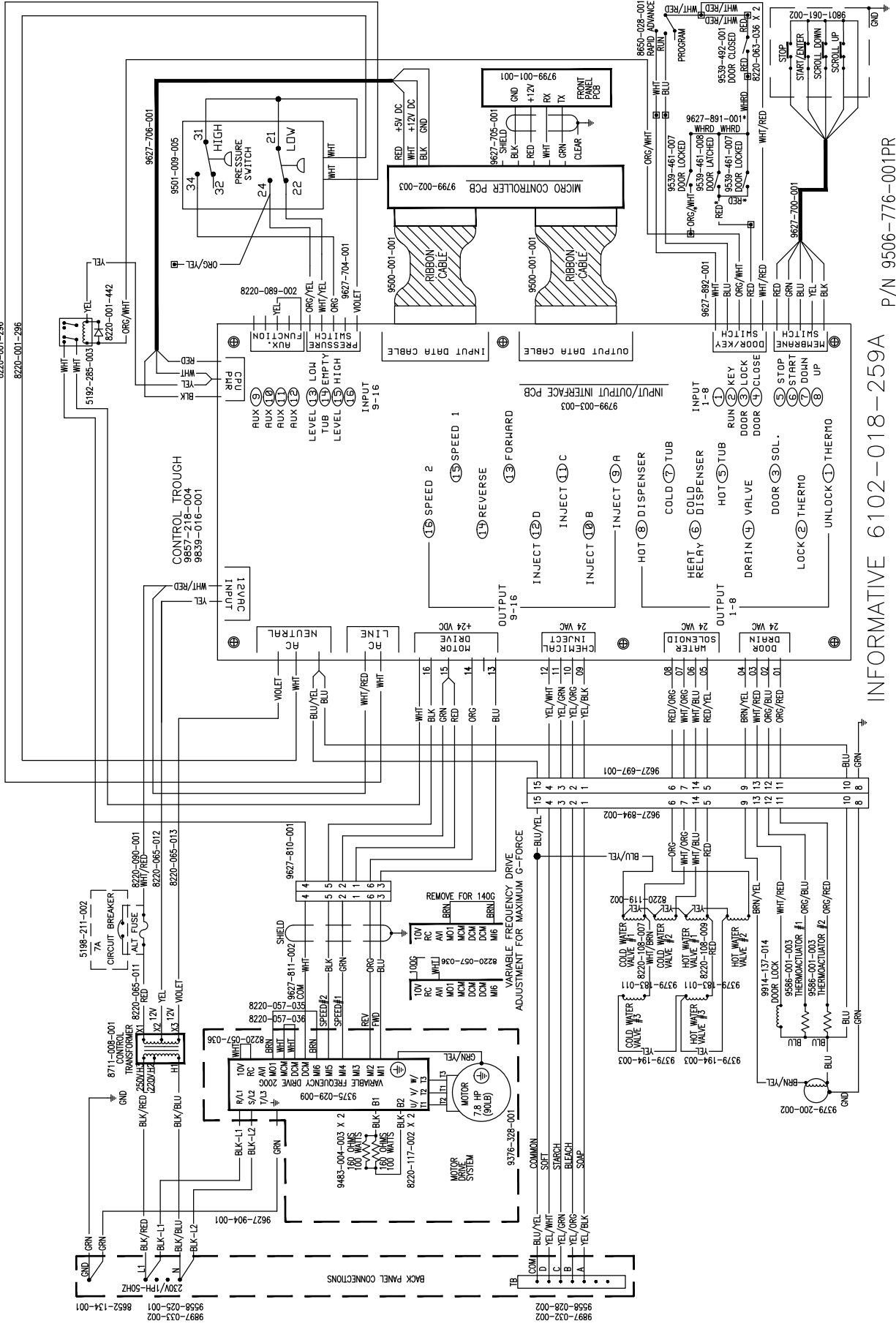

INFORMATIVE 6102-018-259A  
 SCHEMATIC/WIRING DIAGRAM 230V, 1PH, 50 HZ  
 P/N 9506-776-001PR  
 90 LB EXPRESS, OPL, VF DRIVE, 230V, 30 CYCLES  
 WN1450XA-39XN\_X-\_\_\_\_X

## 50HZ Electric Heated Models

KEY	Part Description	T600	T900	Qty
*	Relay	5192-285-003	5192-285-003	2
*	Relay Heater ( 40AMP) 24 vac	5192-290-001	5192-290-001	1
*	Circuit breaker	5198-211-002	5198-211-002	1
*	Pcb Assembly I/O interface	9799-003-003	9799-003-003	1
1	Pcb Assembly -Temp Control	9799-013-001	9799-013-001	1
*	Water Valve Dual	9379-183-007	9379-183-007	2
*	Transformer Control	8711-008-001	8711-008-001	1
*	Cover ( Heater Terminals)	9074-286-002	9074-330-001	1
	Bracket (Shield Mounting)	9029-095-001	9029-095-001	2
*	Filter Line Washer (EP)	9183-032-001	9183-032-001	1
*	Filter -EMI	9183-033-001	9183-033-001	2
*	Filter EMI , 1 phase 24AMP	9183-045-001	9183-045-001	1
*	Drain Valve 3" 24 vac	9379-187-003	9379-187-003	1
*	Strip Terminal Marker injector 24v	9558-028-001	9558-028-001	1
*	Controlsassembly -Trough	9857-152-004	9857-179-001	1
2	Heater Assembly		9870-087-001	9
2	Heater Assembly	9870-087-001		6
*	Terminal Block Power	9897-033-002	9897-033-002	1
*	Terminal Lug solderless	8652-134-002	8652-134-002	1
*	Outer Tub Assembly	9930-139-001	9930-153-002	1
*	Tub & cylinder Assembly	9869-010-001	9869-024-002	1
3	Sensor Assembly	9501-005-002	9501-005-002	1
*	Owners Manual	8514-143-001	8514-190-001	1
*	Wiring Label Schematic	9506-306-001	9506-307-001	1
*	Label Warning Highvoltage	8502-614-004	8502-614-004	3
*	Label Fusing Installtion	8502-619-008	8502-619-006	1
*	Screw #10Bx1/2		9545-008-026	3
*	Screw 6Bx3/8	9545-031-003	9545-031-003	2
*	Screw 6ABx3/4	9545-031-010	9545-031-010	2
*	Screw #6TX5/16	9545-031-011	9545-031-011	2
*	Screw 6-32x1/4	9545-044-004	9545-044-004	3
*	VFD mounting Bracket	9029-095-001	9029-184-001	1
4	Drain Hose Tub to Valve	9242-456-002	9242-459-002	1

# 50HZ Electric Heated Models

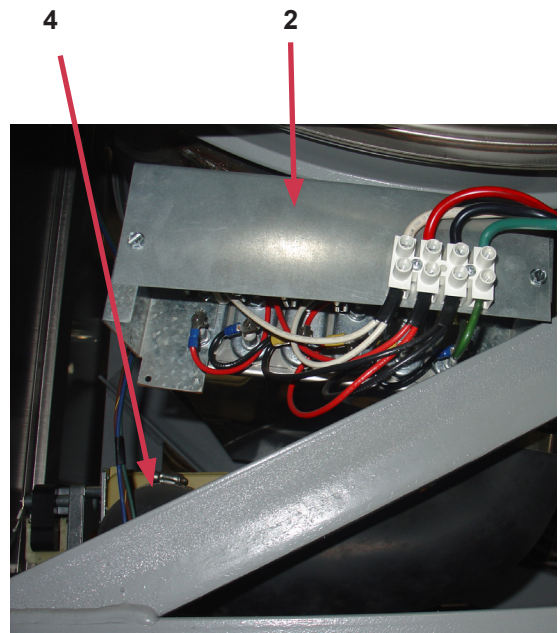
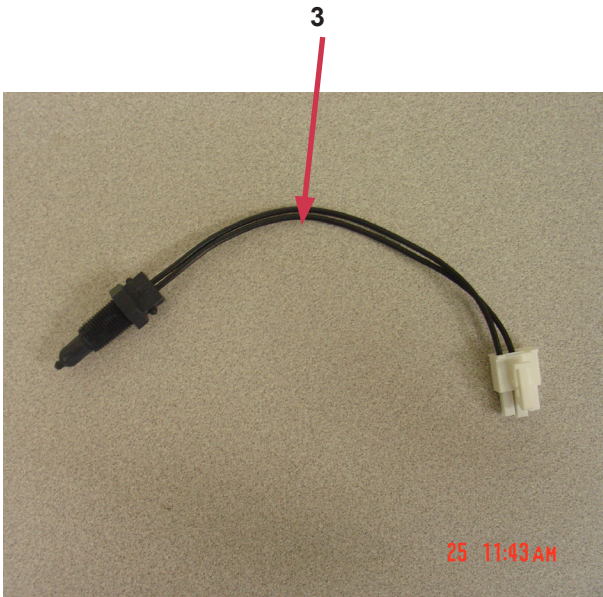
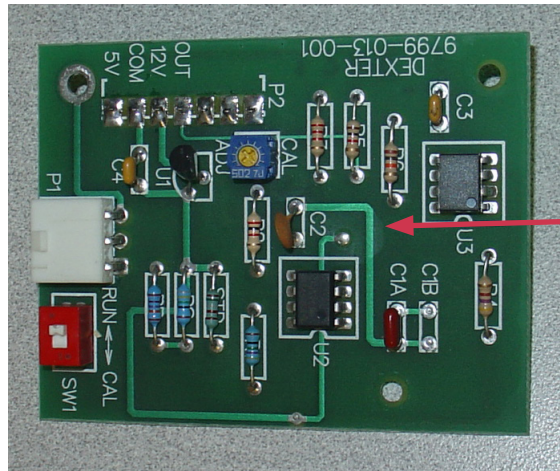

## 50HZ Electric Heated Electric Wires

KEY	Part Description	T600	T900	Qty
*	Wire -Diode	8220-001-442	8220-001-442	2
*	Wire Assy Grn 4"		8220-001-484	8
*	Wire Assy Gry 4"		8220-059-001	6
*	Wire Assy Grn 4"	8220-001-484		5
*	Wire Assy Gry 4"	8220-059-001		4
*	Wire Assy Wht ,8"	8220-059-002	8220-059-002	2
*	Wire Assy Red 8"	8220-059-003	8220-059-003	2
*	Wire Assy Blk 8"	8220-059-004	8220-059-004	2
*	Wire Assy Red 9"	8220-063-002	8220-063-002	1
*	Wire Assy wht/blu 28"	8220-063-003	8220-063-003	1
*	Wire Assy Blu/yel 12"	8220-064-001	8220-064-001	1
*	Wire assy Grn 11"	8220-064-055	8220-064-055	1
	Wire assy. Red 22"	8220-065-011	8220-065-011	1
*	Wire Assy Yel 8"	8220-065-012	8220-065-012	1
*	Wire assy Vio 8"	8220-065-013	8220-065-013	1
*	Wire Assy. Red 29"			2
*	Wire Assy. Blu 29"			1
*	Wire Assy. Red 15"	8220-065-024	8220-065-024	1
*	Wire Assy. Blu 17"	8220-065-018	8220-065-018	1
*	Wire Assy. Wht/Blu 10"	8220-078-006	8220-078-006	1
*	Wire Assy. Yel jumper	8220-083-001	8220-083-001	1
	Wire Assy. Wht 8"	8220-084-001	8220-084-001	1
	Wire Assy. Red 8"	8220-084-002	8220-084-002	1
	Wire Assy. Blk 8"	8220-084-003	8220-084-003	1
	Wiring Harness Heater Assembly Main	9627-755-002	9627-755-002	1
	Wiring Harness TempSensor	9627-762-001	9627-762-001	1
	Wiring Harness Pwr Terminal Block	9627-879-002	9627-879-002	1



# WN0600EA-68XN

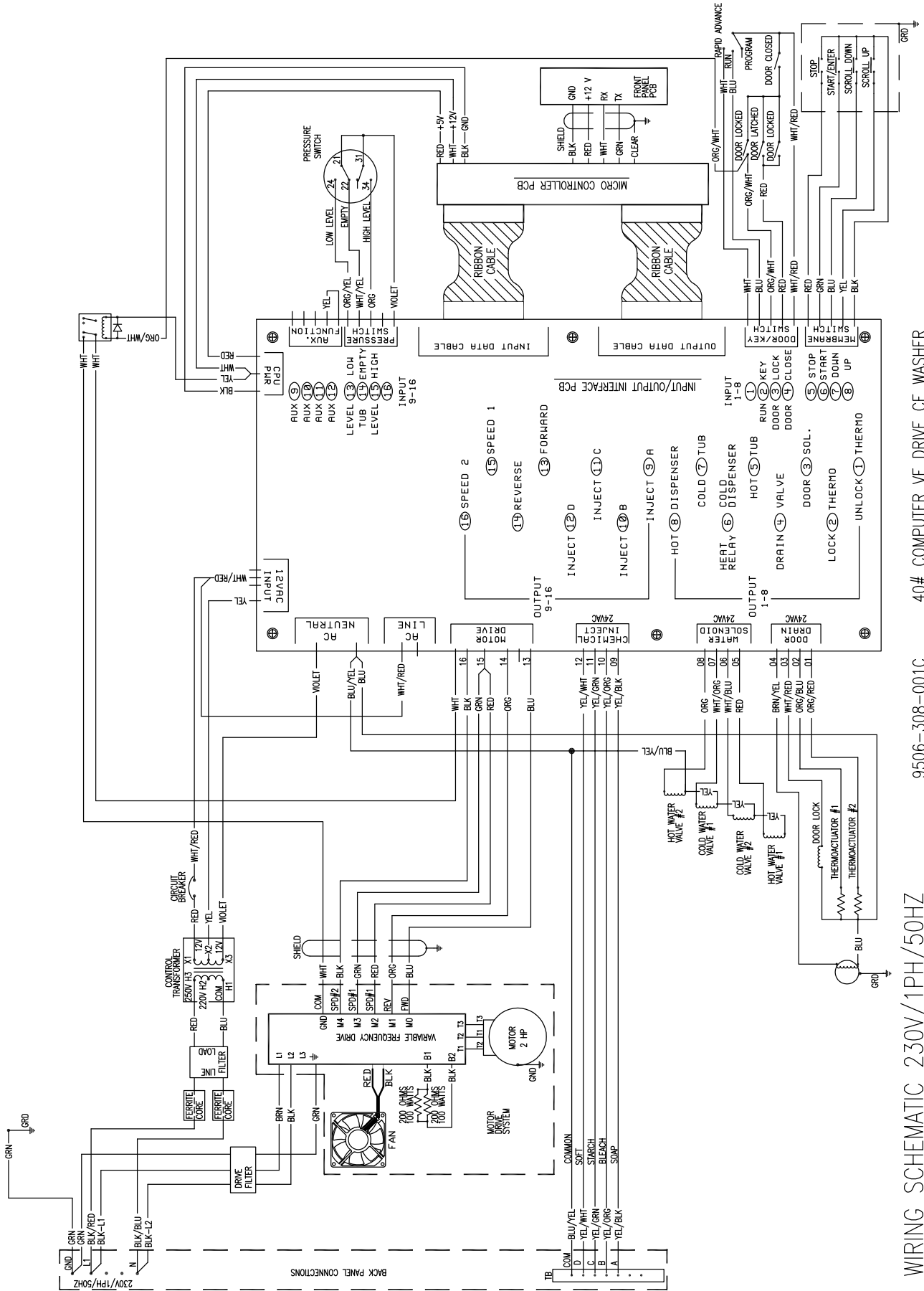

40# COMPUTER VF DRIVE CE WASHER

9506-308-001C

WIRING SCHEMATIC 230V/1PH/50HZ

# WN0900EA-68XN

WIRING SCHEMATIC 380-415V/3PH, 50HZ

9345-912-001H

40# COMPUTER WASHER W/ HEAT OPTION

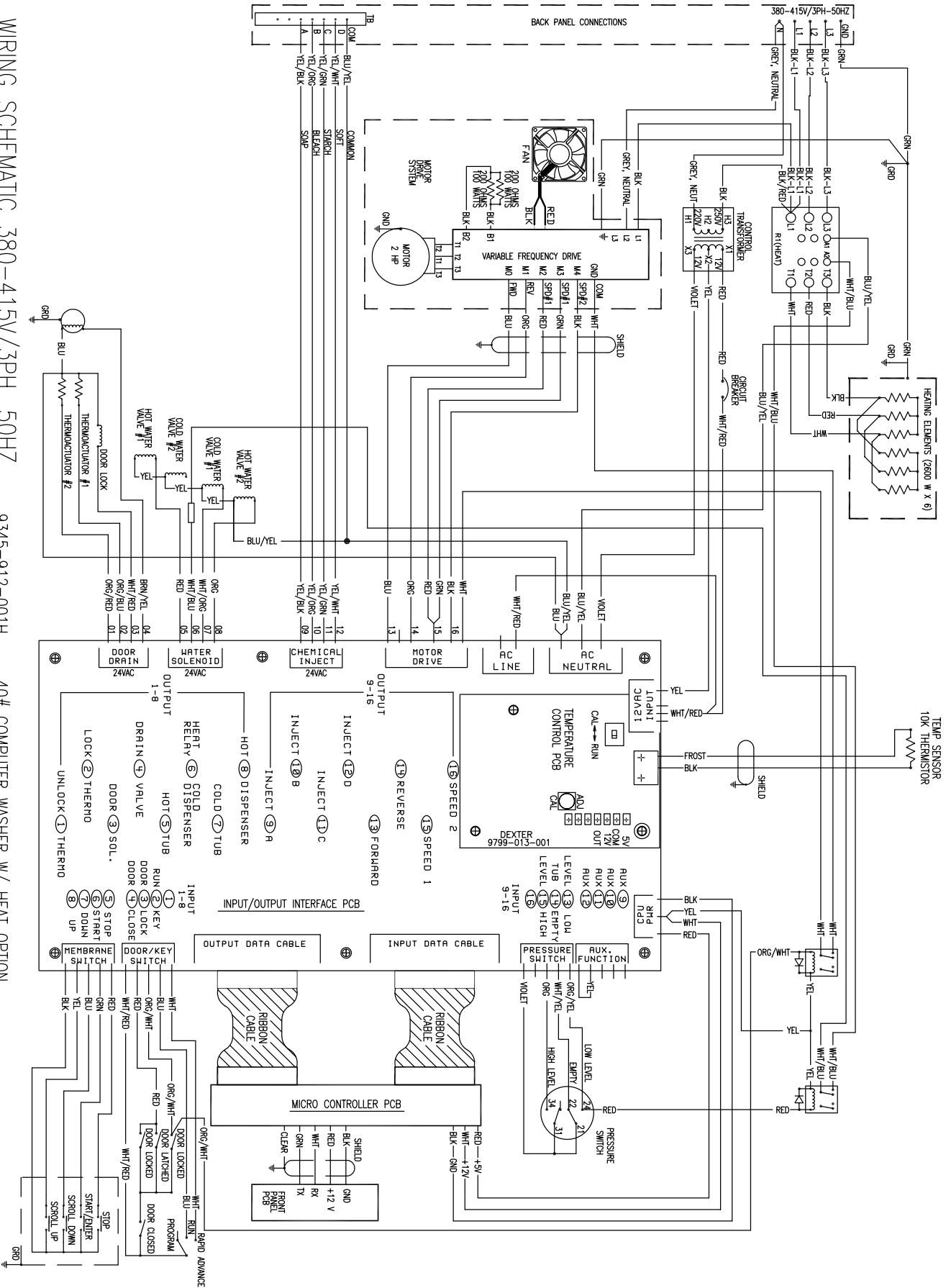

# WN1200EA-68XN

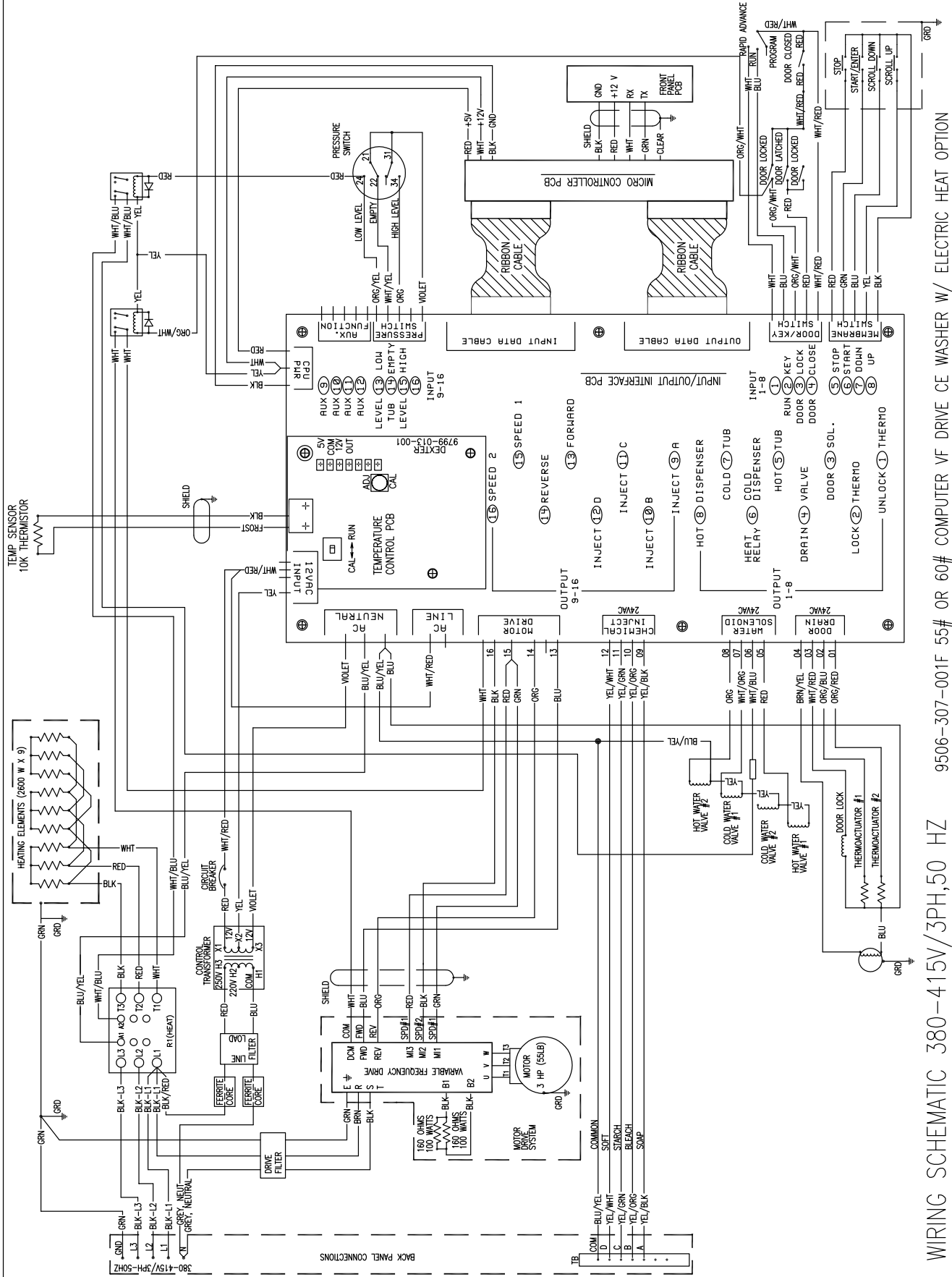

WIRING SCHEMATIC 380-415V/3PH,50 HZ 9506-307-001F 55# OR 60# COMPUTER VF DRIVE CE WASHER W/ ELECTRIC HEAT OPTION

---

# Notes

Lined area for taking notes.