



Section: 6

Dryer Parts Data

SWD

Dryer Cabinet Group

	Description	T-20SWD	QTY
1	Panel Assy., Front- Upper (SS)	9989-592-001	1
*	Insulation Front Panel, half moon (top)	9277-064-001	1
*	Insulation Front Panel, half moon (bottom)	9277-064-002	1
2	Screw, FLHDCR, 10B x- 1 3/4	9545-008-014	4
3	Washer, Finish, #10	8641-585-001	4
*	Nut, Spring	8640-399-001	4
*	Hinge ,Backup Plate	9982-392-001	1
*	Screw, Countersink, 10-32X 1/2	9545-012-003	2
4	Strap, Hinge (SS/Black)	9544-074-002	2
*	Screw, Hinge to Panel	9545-012-028	4
*	Door Assy., Loading Complete-Chrome/BLK/SS	9960-315-002	1
5	Door Assy., Loading-Chrome(ring only)	9960-314-003	1
6	Plate Assy., Hinge (SS)	9982-393-001	1
*	Screw, Hinge to Door	9545-012-015	4
*	Nut, Hinge to Door	8640-413-002	4
*	Cover, Hinge Plate	9074-377-002	1
*	Screw, Phillips-10B x 3/8	9545-008-010	2
7	Glass, Door	9212-002-005	1
8	Gasket, Glass Black	9206-413-003	1
*	Support, Door Glass	9548-117-000	1
*	Tool Install Dryer Door Gasket	8545-064-001	1
9	Gasket, Outer Rim Black	9206-420-006	1
10	Handle, Loading Door	9244-092-001	1
*	Screw, Handle 1/4-20 x 3/8	9545-018-017	2
11	Stud, Door Catch, 3/4	9531-033-002	1
12	Nut, Hex	8640-413-001	1
13	Nut, Acorn	8640-413-003	1
14	Catch, Loading Door	9086-015-002	1
15	Pop Rivet for mtg. catch	8638-190-009	2
16	Screw, Door to Hinge Strap (Special Black Type)	9545-052-001	1
17	Washer, Fiber	8641-436-003	1

Cabinet Group

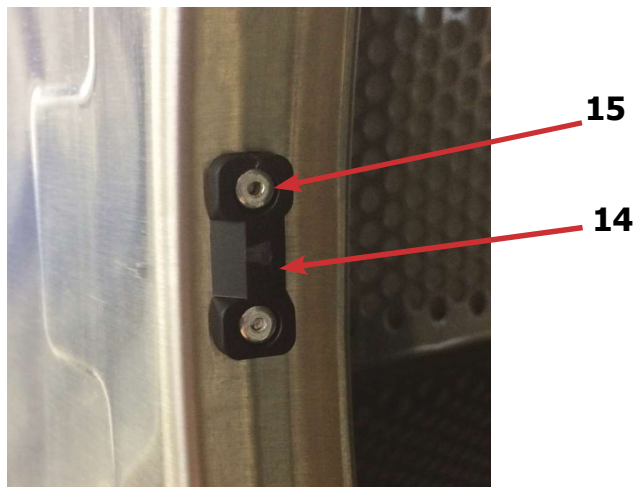

Dryer Cabinet Group

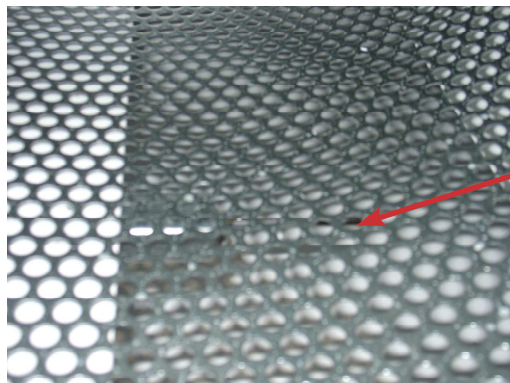

Cabinet Group Continued

Key	Description	T-20 SWD-11	QTY
20	Escutcheon, SWD, Dryer opl	9994-039-001	1
21	Trim, Overlay-Upper Black	9435-052-001	1
*	Screw, #4-40 x 3/16	9545-020-009	12
22	Nameplate Stack Dryer Express Black	9412-240-001	1
*	Lint Drawer Assembly Black	9866-008-005	1
*	Drawer, Front PTD	9974-016-002	1
*	Washer, Flat, #10	8641-581-006	2
*	Washer, Curved-Spring	8641-569-004	2
*	Nut, 10-32	8640-413-007	2
23	Overlay Trim, Lint Drwr-Black	9435-053-003	1
*	Felt Seal (back of lint screen assembly)	9532-074-004	1
*	Lint Screen Assembly ONLY (no front)	9805-036-002	1
*	Replaceable Lint Screen Only	9555-057-011	1
24	Lock-Door Service Thumb Turn	8650-026-002	1
*	Cam, Lock	9095-044-001	1
*	Lint Screen Strap Hold Down Screws 10Bx 1/4	9545-008-001	32
25	Controls Assy, 24VAC, Black	9857-227-001	1
*	Harness, Electronic Control	9627-770-005	1
*	Control Board	9471-016-001	1
*	Screw-trhdtrnx 6bsd1/2blk	9545-031-009	4
*	Harness, Heat Sensor	9627-679-003	1
*	Wire Nut Connector Grey	8640-276-002	2
*	Membrane Switch	9801-111-001	1
27	Sensor Temp/Bracket Control	9501-006-003	2
*	Cover, Cabinet (Top)	9074-374-001	1
*	Insulation Cabinet Cover	9277-041-028	1
*	Screw-hxwshrundrcuthd,10abx3/8	9545-008-024	14
*	Stack Dryer Trunion Puller	9732-243-002	1

Dryer Back Panels and Guards

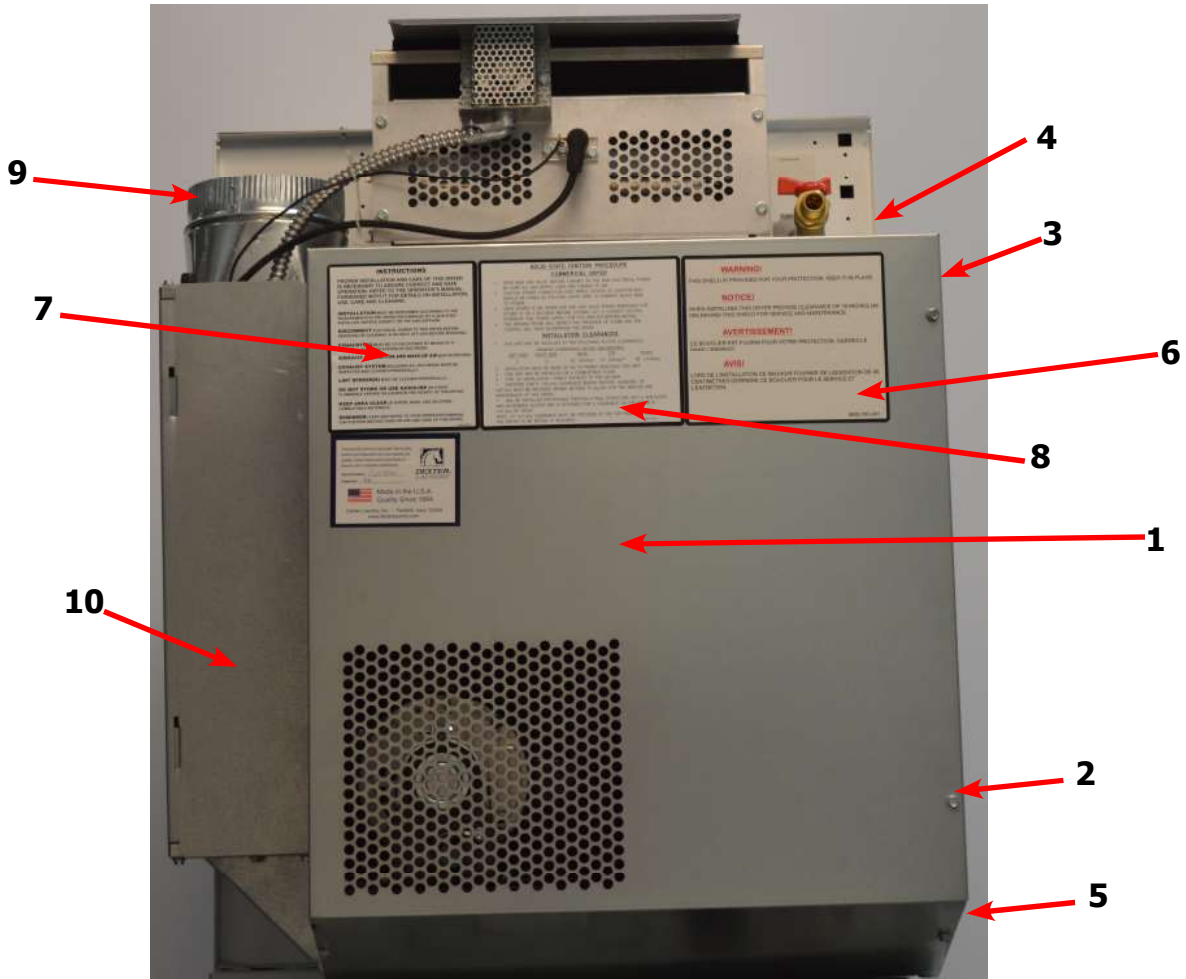

Key	Description	Part Number	Qty
1	Guard, Drive	9208-133-001	1
2	Screw, 10AB x 3/8	9545-008-024	20
3	Panel, Drive Guard,	9208-131-001	1
4	Guard-Small, upper	9208-134-001	1
5	Guard-side,lower	9208-132-001	1
6	Warning, Label	8502-763-001	1
7	Label, Instructions	8502-645-001	1
8	Lighting and Clearance, Label	8527-112-001	1
9	Duct, Transition	9109-127-001	1
*	Optional Duct w/Cleanout	9973-035-001	1
10	Door, Cover-Control Box	9108-141-001	1
*	Cabinet, Cover	9074-374-001	1
*	Insulation	9277-041-028	1
*	Screw, 10AB x 3/8	9545-008-024	10
*	Wiring Diagram & Schematic	9506-821-001	1

Air Flow Switch Assembly

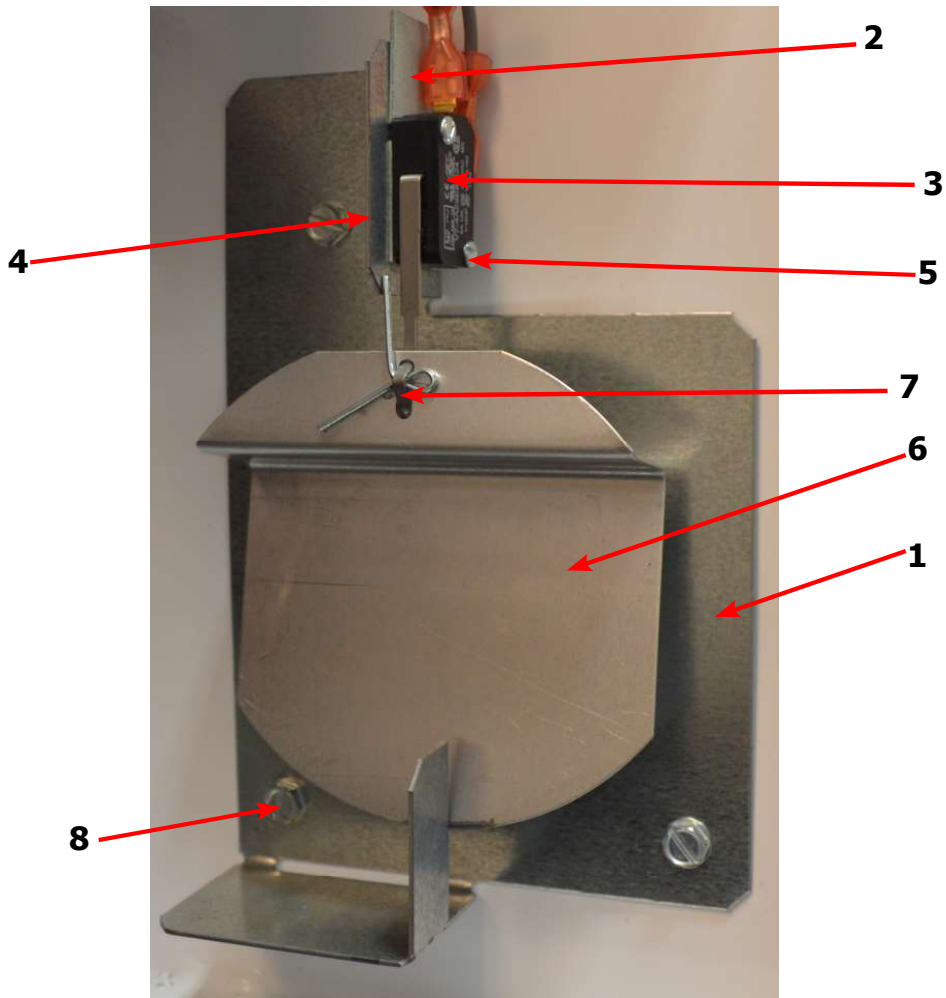

Key	Description	T-30 SWD	QTY
*	Air Flow switch Assy	9801-095-001	2
1	Bracket-Airflow switch	9029-174-001	2
2	Shield-Switch	9550-169-003	2
3	Switch-Micro	9539-461-009	2
4	Nut-Twin, 4-40	8640-401-001	2
5	Screw-.625, 4-40	9545-020-001	2
6	Actuator-Air Flow Switch	9008-007-001	2
7	Pin-Cotter, .09375x.75	9451-169-002	2
8	Screw, 10BX x 1/4	9545-008-001	3
*	Harness Assembly, Overtmp/Airflow	9627-861-001	1

Dryer Burner Housing Group

Key	Description	T-20 SWD	QTY
*	Housing Assembly, Burner (All sheet metal parts not listed)	9803-221-001	1
1	Panel, Back Burner Housing	9454-949-001	1
2	Screw, 10B X 1/4"	9545-008-001	4
3	Angle, Burner Support	9003-220-001	1
*	Screw, 10B x 3/8"	9545-008-006	2
4	Burner, Main	9048-023-001	2
*	Screw 10AB x 3/8"	9545-008-006	2
5	Electrode-ignition	9875-002-003	1
6	Screw, Electrode Mtg 8B x 1/4"	9545-045-001	2
7	Valve, Gas Shut Off (not provided on machine)	9379-196-001	1
8	Pipe Nipple, 1/2 x 4 1/2, BLK	8655-073-044	1
9	Elbow, 1/2 x 90, BLK	8615-104-037	1
10	Pipe Nipple, 1/2 x 3 1/2, BLK	8655-073-047	1
11	Control Assy, Gas	9857-134-001	1
*	Wireasy-yel,47/8"	8220-001-466	1
12	Manifold, Assy	9381-012-001	1
*	Orifice, Burner-Natural #40	9425-069-030	2
*	Orifice, Burner-LP #54	9425-069-031	2
13	Bracket, Manifold	9029-306-001	2
14	Pipe Plug in end of Burner Manifold	8615-104-038	1
*	Screw, 10AB x 3/8"	9545-008-006	2
15	Bracket, High Limit Thermostat	9029-192-001	1
16	Thermostat, Hi-Limit	9576-203-002	1
*	Spacer, Hi-Limit	9538-142-001	2
*	Screw 8B x 3/4"	9545-045-007	2
17	Cover, Hi-Limit Stat	9074-329-001	1
*	Screw, 10AB x 3/8"	9545-008-006	2
18	Thermostat, Safety Shutoff	9576-207-006	1
19	Screw, 10AB x 3/8"	9545-008-006	2
*	Control, Ignition Fenwall (3 trybox)	9857-182-001	1
*	Kit, LP Conversion 20Lb Stack Kit	9732-102-034	1
*	Make-Up Air Vent Kit	9732-332-001	1

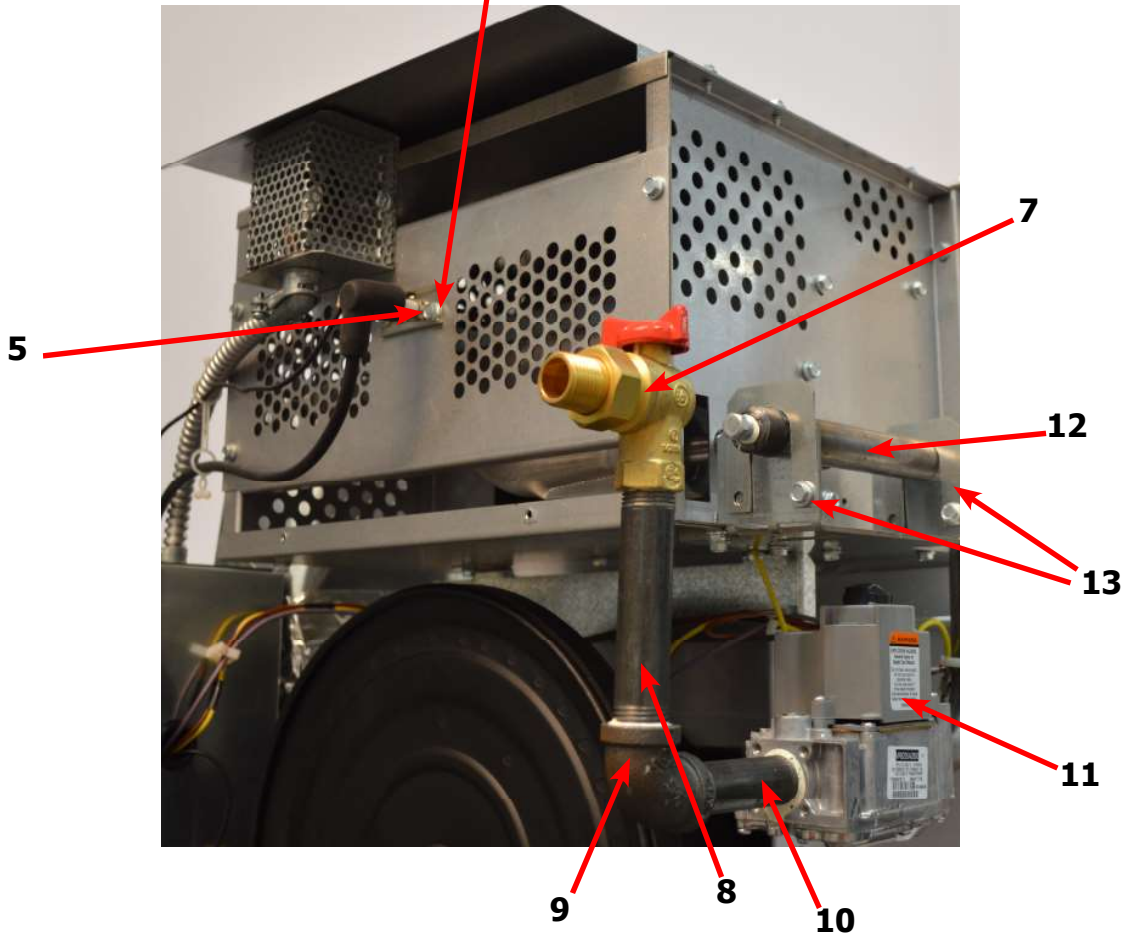
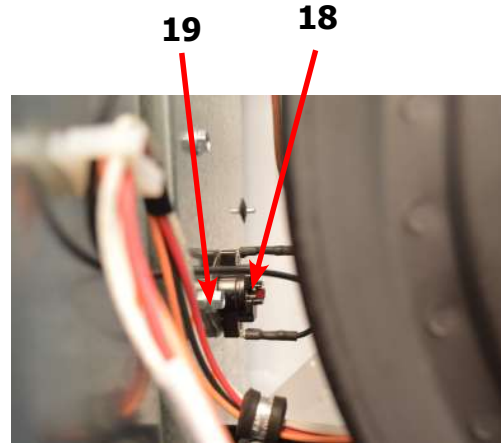
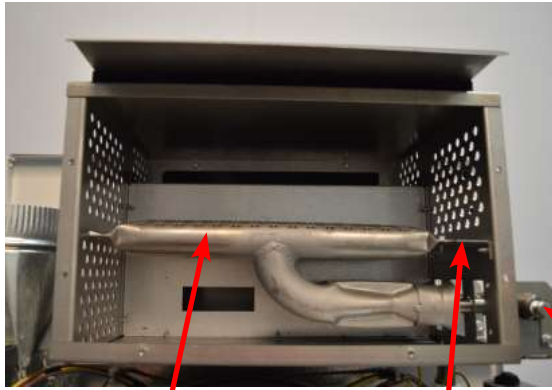
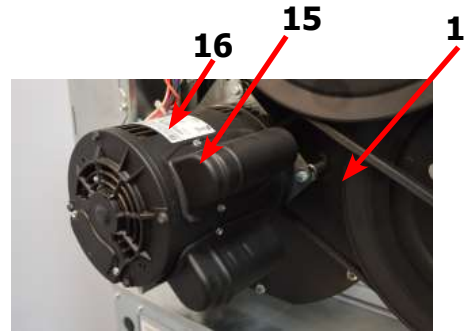
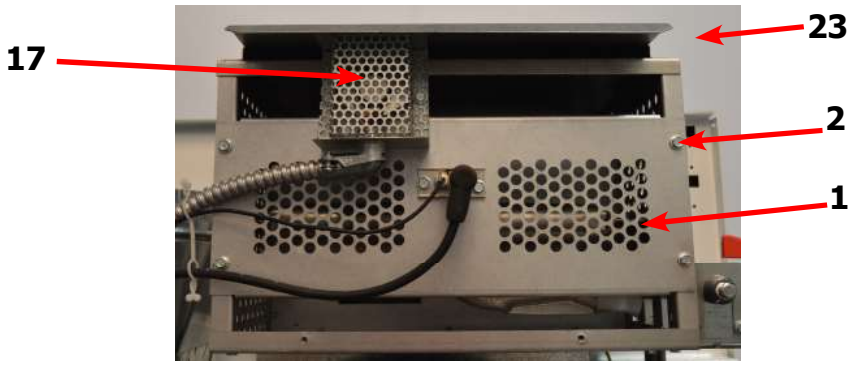

Bearing Housing Group

Key	Description	T-20 SWD	QTY
	Bearing Housing Complete Assy (Includes bearings & Spacer)	9803-160-003	1
1	Housing, Bearing	9241-161-002	1
*	Spacer, Bearing	9538-139-002	1
2	Bearing, Ball, Front & Rear	9036-130-001	2
3	Screw-Wizlock, 3/8-24x3/4	9545-049-002	4
4	Nut, 5/16-18	8640-400-002	4
5	Screw, 3/8-24x1	9545-049-001	2
6	Nut, 3/8-24	8640-415-002	2

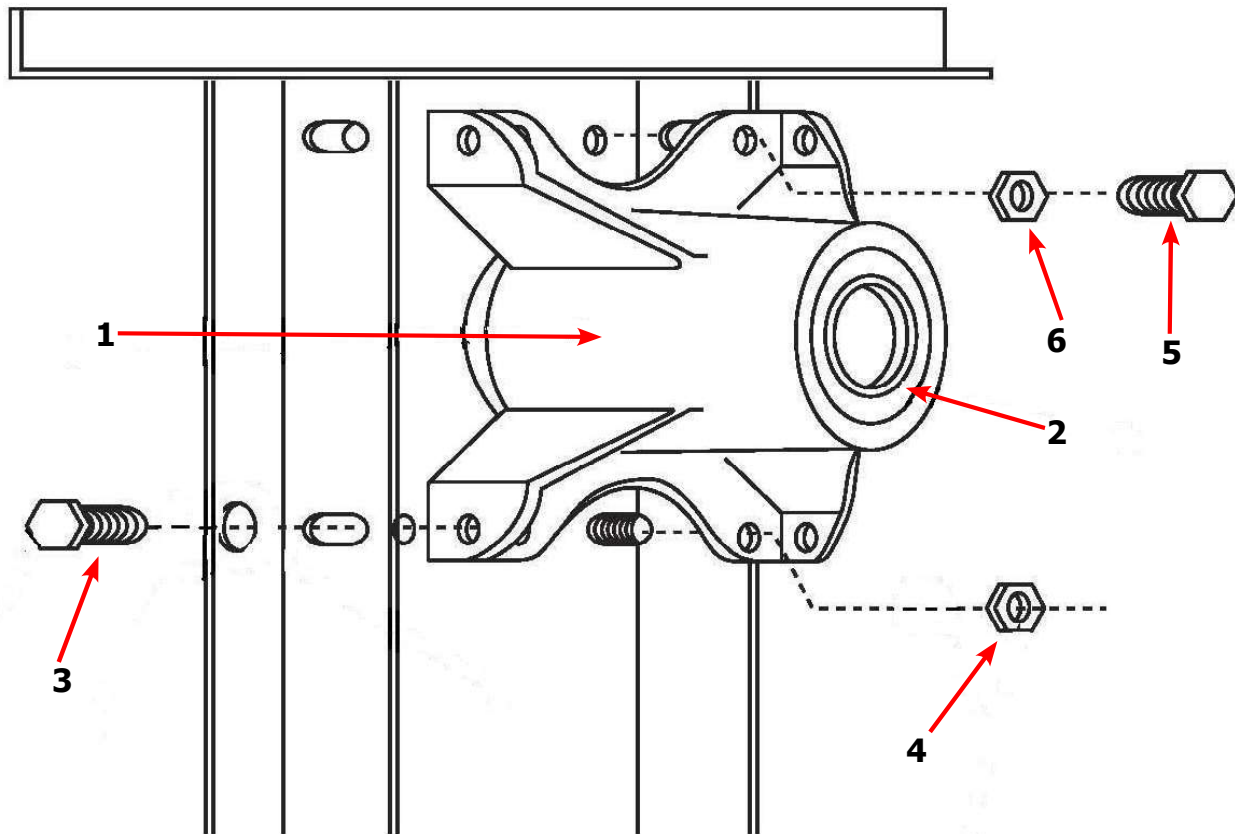

Tumbler Group

Key	Description	T-20 SWD	QTY
*	Tumbler Assy Complete W/Spider (GALV)	9848-156-001	1
1	Tumbler Assy (Galvanized)	9848-155-001	1
*	Tumbler Assy Complete W/Spider (SS & Galv front)	9848-156-002	1
1	Tumbler Assy (Stainless Galvanized front)	9848-155-002	1
2	Rod, Tumbler	9497-019-004	3
3	Washer, Special	8641-554-001	3
4	Shim	9552-013-000	AR
5	Spider Assy	9568-018-001	1
6	Nut, Wiz Lock	8640-415-004	3
7	Spacer-Shaft	9538-164-001	1
8	Tolerance Ring	9487-234-005	1
9	Pulley, Driven	9908-052-002	1
10	Washer -Flat 1/2	8641-581-026	1
11	LockWasher - IntTooth, 1"	8641-582-016	1
12	Screw, 1/2-13x1 1/4	9545-017-009	1
*	Belt, Drive	9040-073-013	1
*	Belt,Driven (Motor)	9040-076-012	1

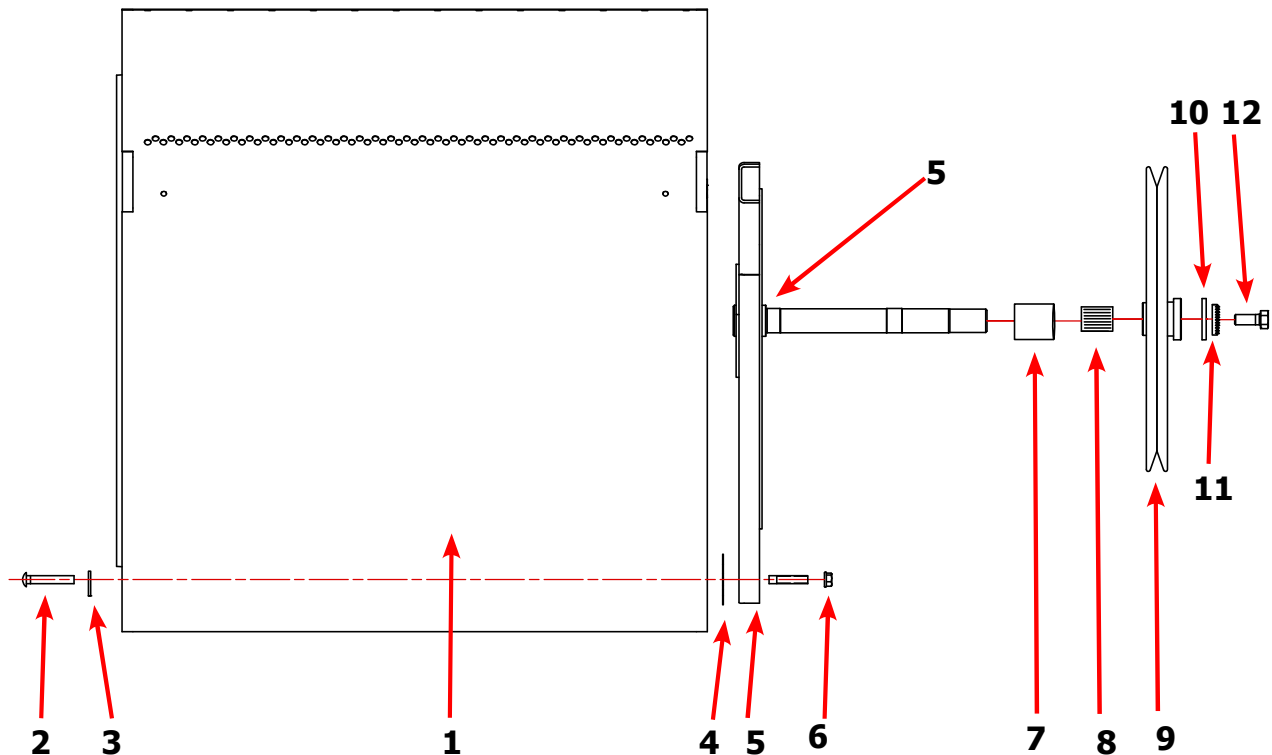

	Description	T-20 SWD	QTY
*	Switch Assy, Air Flow	9801-095-001	1
1	Switch, Air Flow	9539-461-009	1
2	Bracket, Switch- Air Flow	9029-174-001	1
3	Actuator, Switch	9008-007-001	1
4	Pin, Cotter	9451-169-002	1
5	Screw 4-40 x 5/8"	9545-020-001	2
*	Nut, Special Twin .#4-40	8640-401-001	1
*	Shield, Switch	9550-169-003	1
*	Screw 10 Bx 1/4"	9545-008-001	3
6	Motor, Drive	9376-332-001	1
*	Pulley-motor,60hz	9453-185-001	1
*	Screw-set,5/16-18x1/2	9545-028-013	1
*	Impeller (W/Setscrew)	9278-045-001	1
7	Plate, Motor Mtg	9982-390-002	1
*	Bolt 3/8" - 16 x 3/4"	9545-029-008	1
*	Lockwash Spring 3/8	8641-582-003	1
8	Screw, Motor to Plate Screw-hxflgwhzlk,5/16-18x5/8	9545-014-004	4
*	Nut-hextwinwhzlk,5/16-18	8640-400-003	4
9	Nut 1/4x20 Motor Plate to Cabinet	8640-414-007	7
10	Clamp-cable,3/4	8654-125-004	2
*	Screw-hxhdsldtmach,12abx1/2	9545-048-001	2
11	SupportAssy, Intermed. Pulley	9991-053-002	1
12	Bolt, Rd Hd 3/8-16 x 1 1/4	9545-029-010	3
13	Bolt, 3/8-16 x 1 1/2	9545-029-012	1
12	Nut Flange Wiziock 3/8" - 16	8640-415-004	3
*	Washer, Flat	8641-581-035	1
14	Arm Assy-Tension, Complete	9861-022-001	1
*	Washer, Flat	8641-581-035	1

Rear View Photos

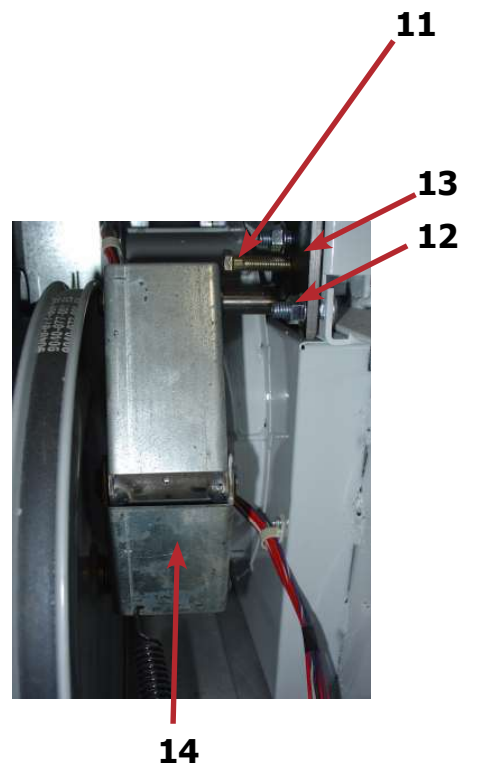
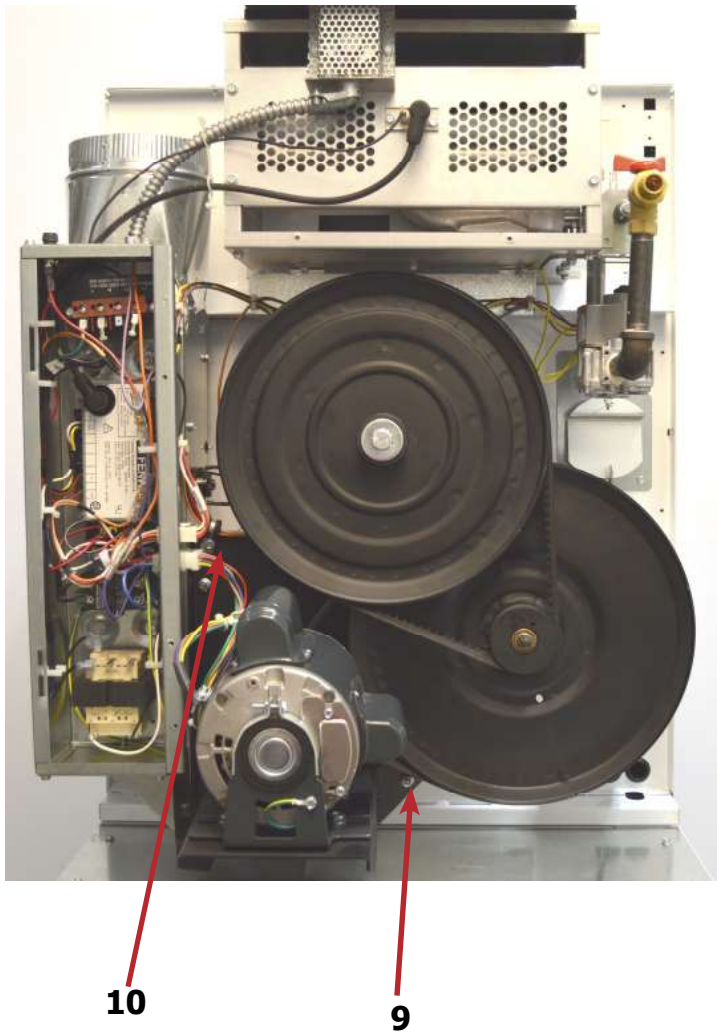
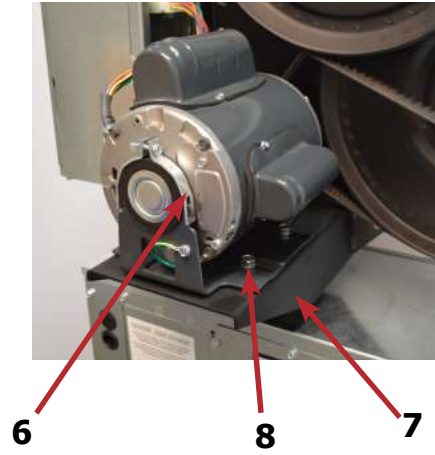
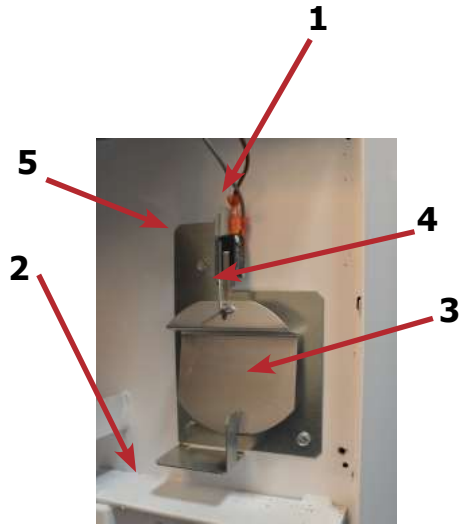

	Description	T-20 SWD	QTY
14	Arm Assy-Tension, Complete	9861-022-001	1
*	Washer, Flat	8641-581-035	1
15	Ring-Retaining	9487-200-003	1
16	Pulley Assy, Intermediate with bronze flange bearing	9908-053-003	1
*	Bearing - Bronze Flange	9036-145-002	1
*	Spacer-Shaft (See Tumbler Group for Expanded View)	9538-164-001	1
*	Tolerance Ring	9487-234-005	1
17	Pulley, Driven	9908-052-002	1
18	Washer -Flat	8641-581-026	1
18	LockWasher - IntTooth, 1/2"	8641-582-016	1
18	Screw, 1/2-13x1 1/4	9545-017-009	1
19	Belt, Drive- Motor	9040-076-012	1
20	Belt, Drive- Tumbler	9040-073-013	1
21	Spring, Tension	9534-319-002	1
22	Chain, Tension	9099-012-011	1
23	Hook, Tension	9248-022-002	1
*	Damper Inside Duct Exhaust	9125-009-001	1
24	Pin, Damper Hinge	9451-146-007	1
*	Box-duct.lower	9041-113-001	1
*	Nut, Spring	8520-141-000	1
*	Screw #10B x 1/2	9545-008-026	3
*	Cover Duct Upper	9074-372-001	1
*	Base Duct	9047-121-001	1
*	Screw 10ABx 3/8"	9545-008-024	40
26	Impeller, W/Set Screws	9278-045-001	1
27	Pulley, Motor	9453-185-001	1
28	Bracket for Wire Harness Under Burner Housing	9029-305-001	1

Rear View Photos

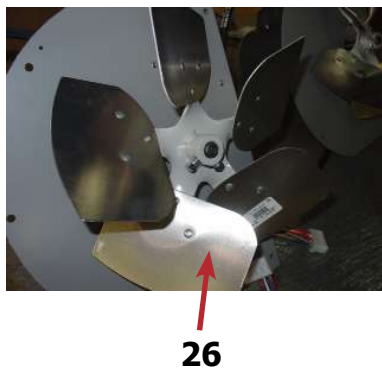
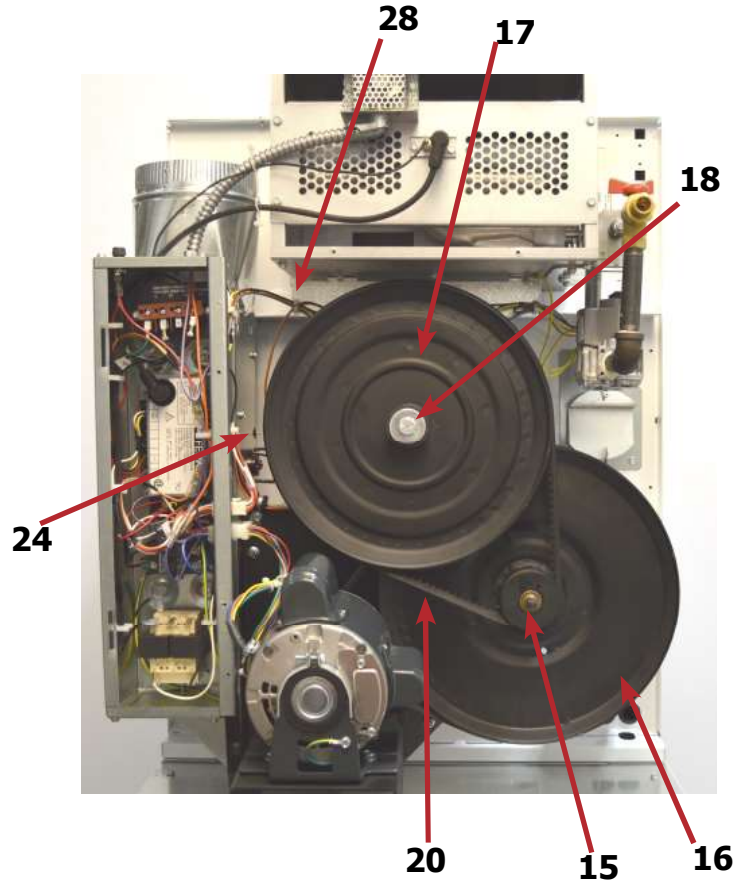
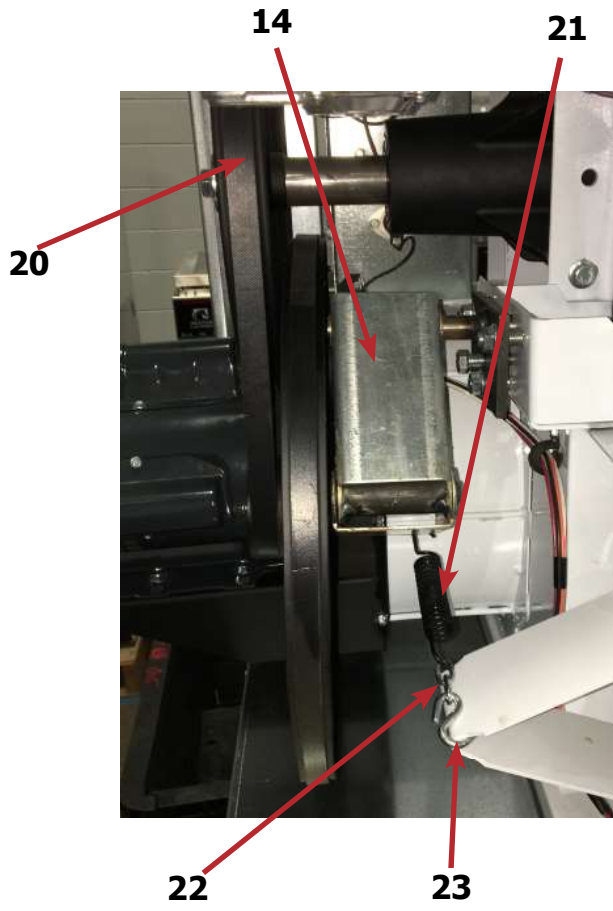

Control Assembly Group

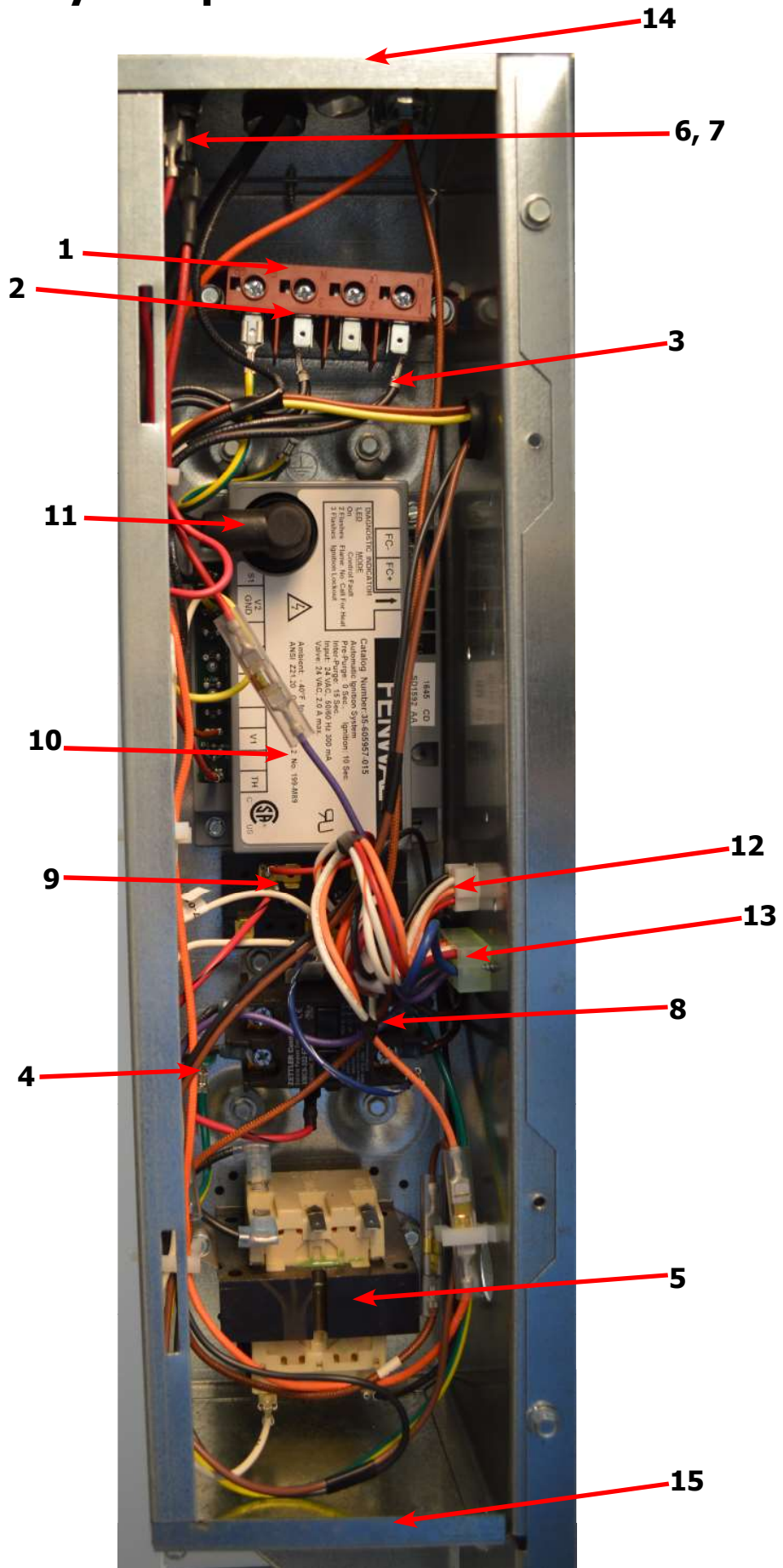

Control Assembly Group

Key	Description	T-20 SWD	QTY
*	Control, Rear	9857-232-001	1
*	Bracket, Terminal Block Power	9029-202-001	1
1	Strip, Terminal Marker	9558-029-003	1
2	Terminal-Block, Power, 4 Pole	9897-035-001	1
*	Screw, 10AB x 3/8"	9545-008-024	6
3	Harness Assembly-Power Main Fork, Upper	9627-859-007	1
4	Wire Assembly-Ground, GRN/YEL, 7"	8220-137-002	1
*	Lock Washer, Ext tooth	8641-582-006	1
*	Screw, 10-32 x 1/2"	9545-008-027	1
5	Transformer, 208/240/60Hz. 24/120VA	8711-007-002	1
*	Screw, 10AB x 3/8"	9545-008-024	2
6	Fuse Holder Assembly	9200-001-002	1
7	Fuse, 1.5Amp/250V-Fast Acting	8636-018-001	1
8	Relay, Motor, 30Amp 24VAC	5192-299-002	1
*	Screw, Phillips, 8AB x 1/2"	9545-045-012	2
9	Terminal Block, Power	9897-026-001	1
*	Screw, Phillips, 8AB x 1/2"	9545-045-012	2
*	Harness-Assembly, Low Voltage, Upper	9627-867-011	1
10	Ignition Module	9857-182-001	1
*	Screw, 10AB x 3/4"	9545-008-018	2
11	Wire Assembly, High Voltage	9631-403-009	1
*	Door-Control Box	9108-141-001	1
*	Screw, 10AB x 3/8"	9545-008-024	3
12	Harness, Main (Internal Box)	9627-887-004	1
*	Harness Main Extention (External Box)	9627-770-005	1
13	Harness Motor	9627-864-007	1
14	Control Box Panel Upper	9454-943-001	1
15	Control Box Panel Lower	9454-944-001	1
*	Control Box Wrapper	9636-216-001	1
*	Wire Red/Black 8"	8220-062-047	1
*	Wire White #11, 14"	8220-062-038	1
*	Wire-Blue/White 5.5"	8220-062-026	1
*	Wire Black/Red #9 9"	8220-146-001	1

Door Switch Group

Key	Description	T-20 SWD	QTY
1	Door Switches	9539-487-001	2
2	Bracket-Mounting lint tray switch	9029-297-001	1
3	Conduit-Wire	6068-049-001	1
*	Grommet Wire 1/2 i.d.	9029-089-001	1

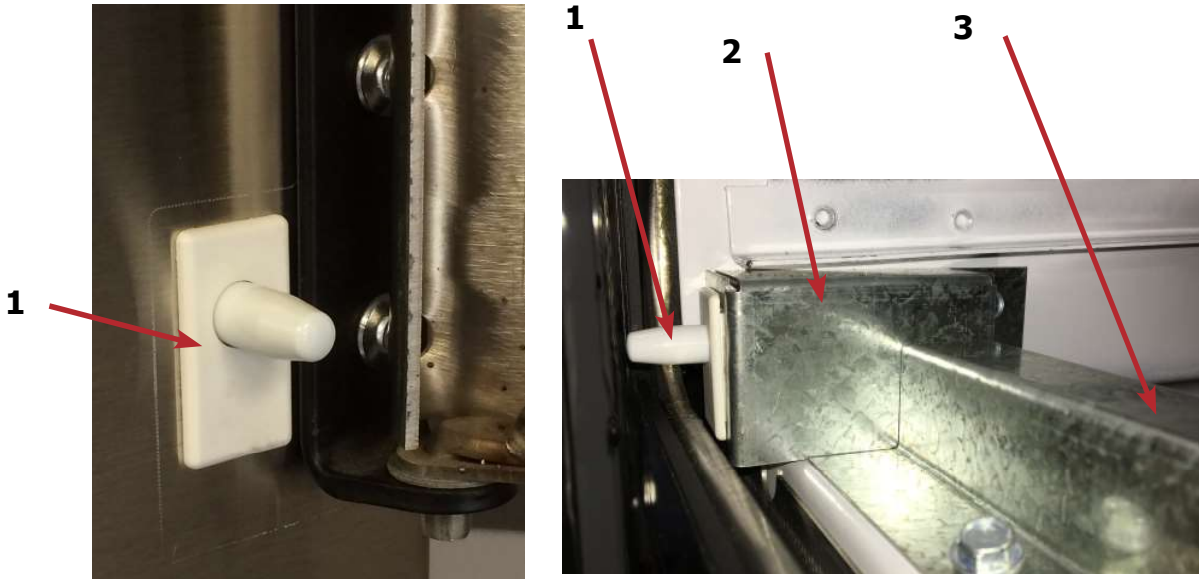

Hinge Plate Cover

Key	Description	T-20 SWD	QTY
1	Cover-Hinge, Black	9074-377-002	1
2	Screw-TRHDCR, 10B x 3/8, Black	9545-008-010	2

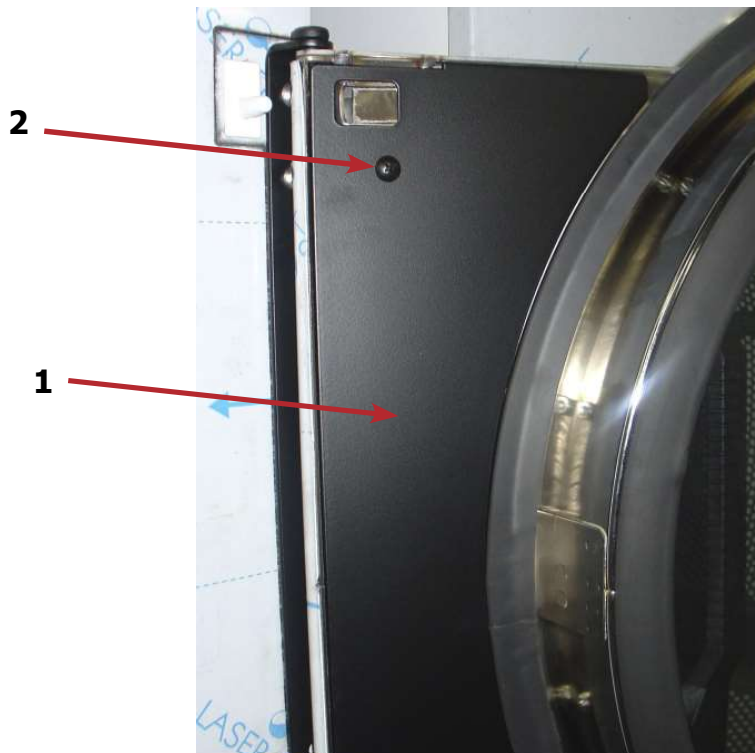

Control Group

Key	Description	T-20 SWD	QTY
	Control Assembly	9857-227-001	1
1	Membrain Switch OPL Black	9801-111-001	1
*	Wire Assembly Green/Yellow	8220-137-001	1
*	Wire Assembly Green	8220-001-478	1
2	Nut-Hex #6-32	8640-411-003	1
3	Nut-Hex #6-32	8640-411-001	3
4	PCB Assyembly-Controller opl	9471-016-001	1
5	Plastic Spacer #6x1/2	9538-157-016	4
6	Plate Assyembly opl ptd	9982-391-002	1

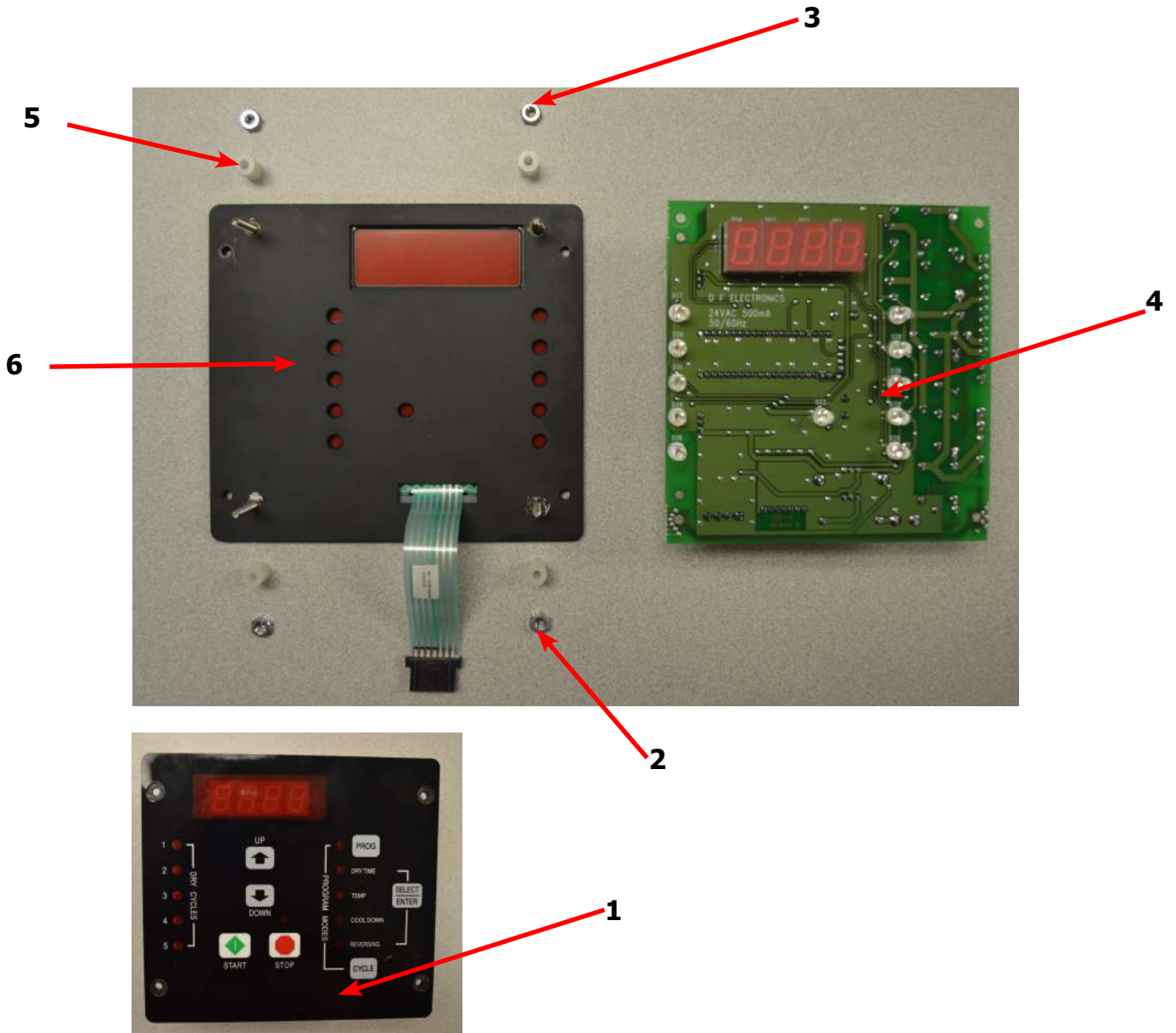

Wiring Diagram

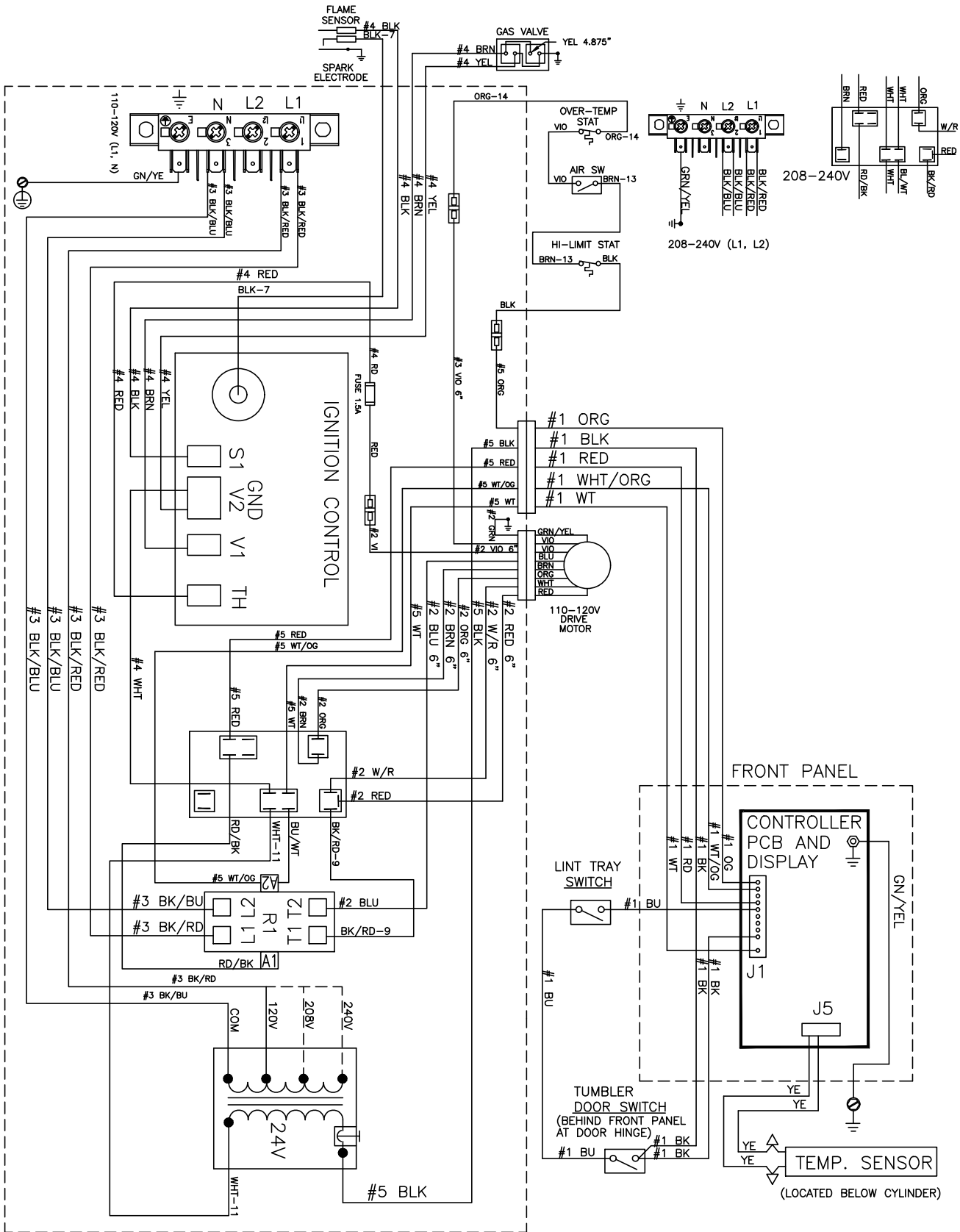

9506-821-001PR WIRING DIAGRAM DNS020N_-15_B_X-____-__X

IMPORTANT: RETAIN THIS ELECTRICAL DIAGRAM FOR SERVICE.

Wiring Schematic

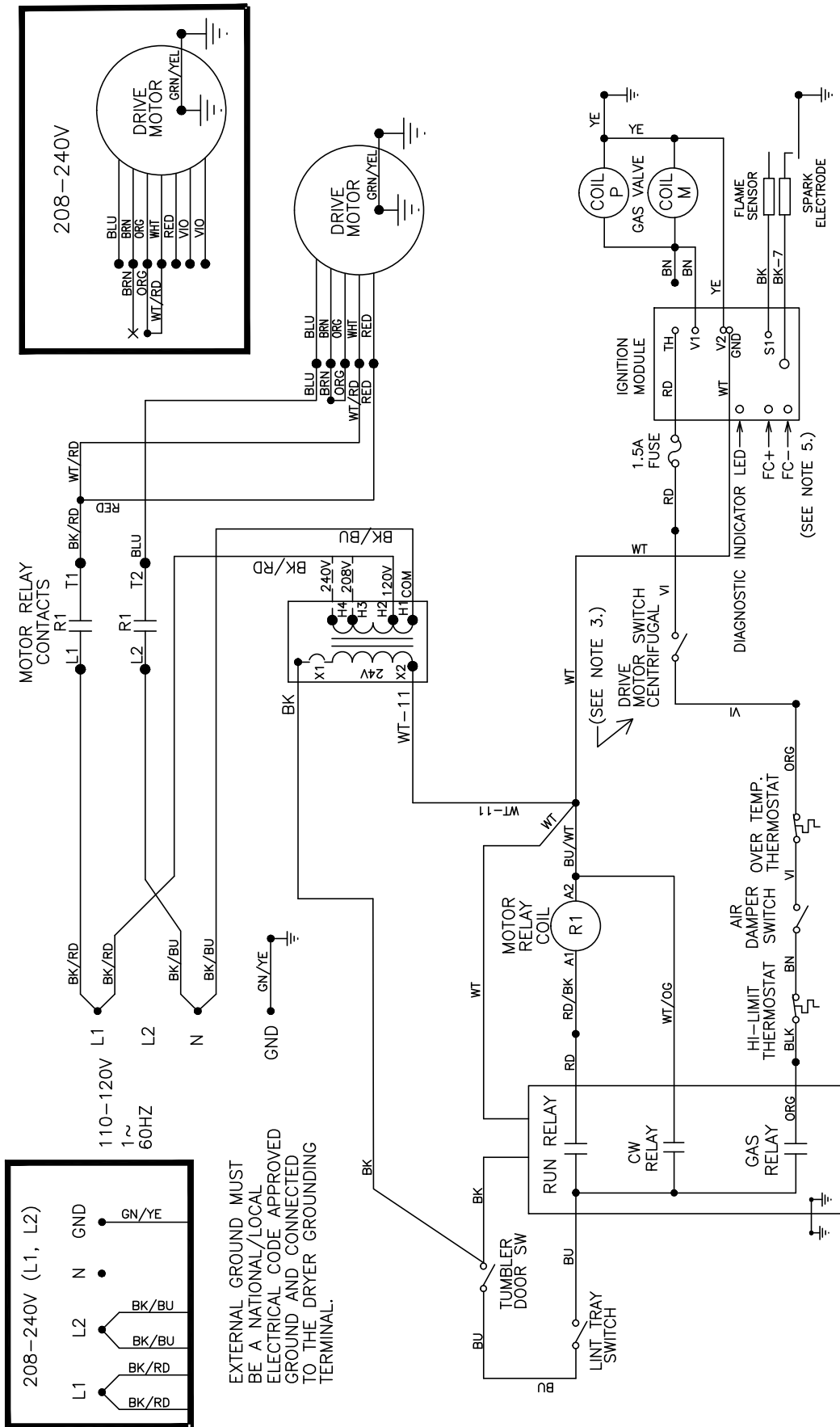

NOTES:

1. DOOR SWITCHES—N.O., CLOSED WHEN DOORS ARE CLOSED.
2. DRYER STARTS WHEN THE DOORS ARE CLOSED, A CYCLE IS SELECTED, AND THE START BUTTON IS PUSHED. THERE IS AN AUTOMATIC COOL DOWN AT THE END OF THE CYCLE.
3. CENTRIFUGAL SWITCH—N.O., CLOSURES WHEN MOTOR IS UP TO SPEED.
4. REFER TO OWNER'S MANUAL FOR DESCRIPTION OF OPERATION AND REQUIREMENTS FOR HEATING CIRCUIT.
5. WITH A DC MICROMMETER, FLAME CURRENT CAN BE MEASURED AT TEST POINTS. READING SHOULD BE 0.7uA DC OR HIGHER.

CAUTION: LABEL ALL WIRES PRIOR TO DISCONNECTION WHEN SERVICING CONTROLS. WIRING ERRORS CAN CAUSE IMPROPER AND DANGEROUS OPERATION. VERIFY PROPER OPERATION AFTER SERVICING.

ATTENTION: AU MOMENT DE L'ENTRIEN DES COMMANDES, ÉTIQUETEZ TOUS LES FILS AVANT DE LES DÉBRANCHER. DES ERREURS DE CÂBLAGE PEUVENT ENTRAÎNER UN FONCTIONNEMENT INADÉQUAT ET DANGEREUX. S'ASSURER QUE L'APPAREIL FONCTIONNE ADEQUATEMENT UNE FOIS L'ENTRIEN TERMINÉ.

9506-821-001PR 9506-821-001PR DNS020N_-15_B_X-_____X

Section: 7

50 Hz Gas Dryer

-39 T-20 SWD 50 Hz Parts

Key	Description	Part Number	Qty
*	Strip, Terminal Marker -39 Models	9558-029-004	1
1	Transformer	8711-007-002	1
*	Instructions, Transformer Connect	8507-230-003	1
2	Ignition Control -39 Models	9857-182-001	1
*	Harness-Ignition Control,	9627-867-011	1
3	Wire Assembly High Voltage	9631-403-009	1
4	Motor	9376-332-001	1
5	Pulley, Motor Drive	9453-185-002	1
6	Harness Motor Extension	9627-864-007	1
*	Wiring Label Schematic/Diagram -39 models	9506-823-001	1
*	Owner's Manual	8514-282-001	1
*	Lint Drawer Assembly -39 Models	9866-008-005	1

Rear View Photos

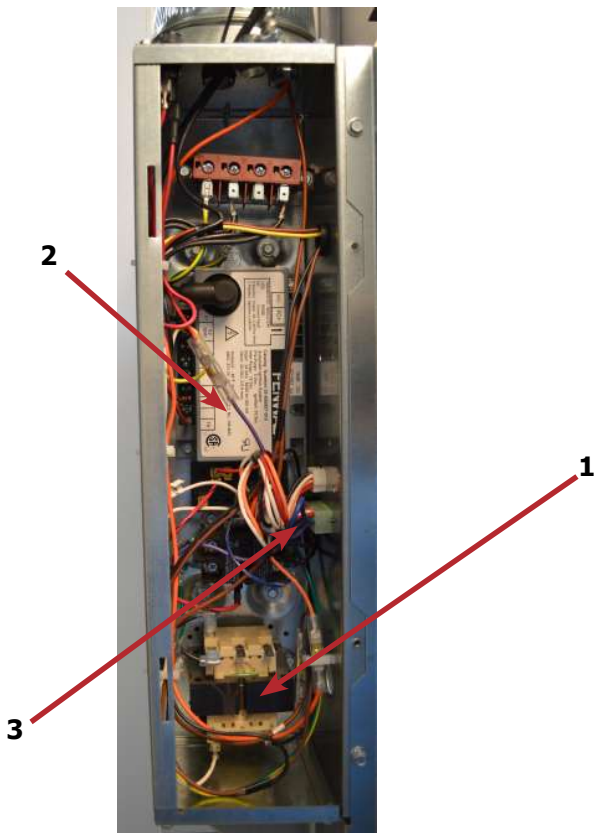
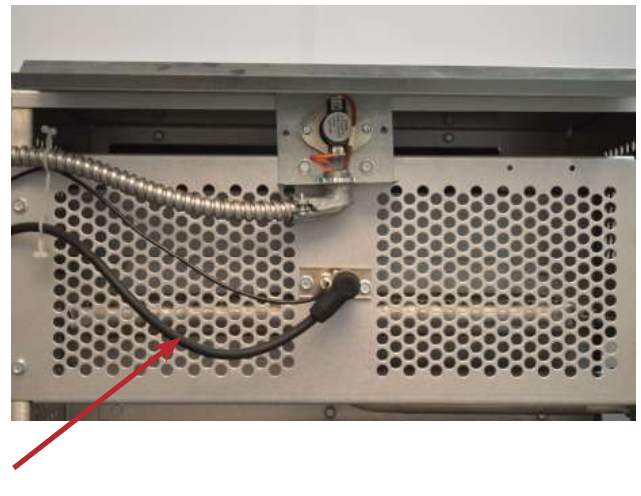
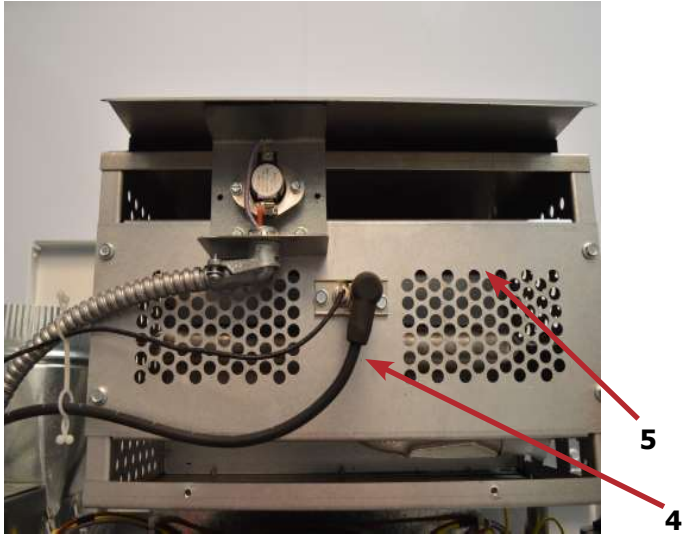

T-20 SWD -39 Gas Control Parts

Key	Description	Part Number	Qty
1	Kit-Honeywell VR86 Valve Flange	9732-162-001	1
*	Orifice, Main Burner #43	9425-069-025	2
2	Gas Control Valve	9857-132-004	1

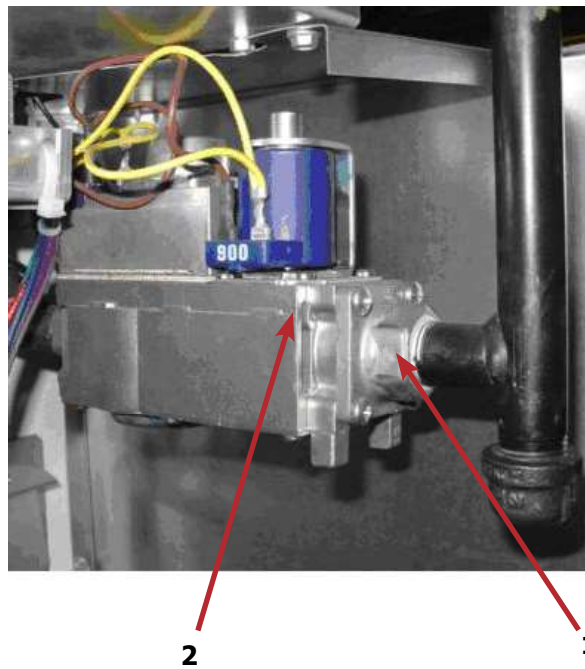

Air Flow Switch Assembly

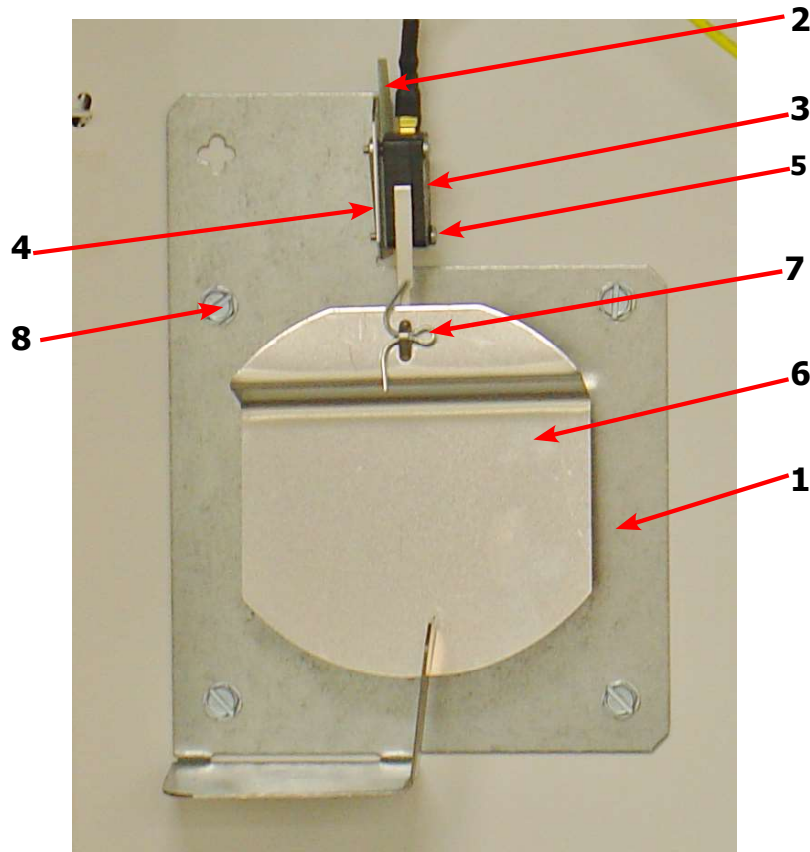

	Description	T-20 SWD-39	QTY
*	Air Flow switch Assy	9801-095-002	1
1	Bracket-Airflow switch	9029-174-002	1
2	Shield-Switch	9550-169-003	1
3	Switch-Micro	9539-461-009	1
4	Nut-Twin, 4-40	8640-401-001	1
5	Screw-.625, 4-40	9545-020-001	1
6	Actuator-Air Flow Switch	9008-007-001	1
7	Pin-Cotter, .09375x.75	9451-169-002	1
8	Screw, 10ABx1/4	9545-008-001	4
*	Harness Assembly, Overtemp/Airflow	9627-861-001	1

Wiring Schematic for Dryer 50hz 230V -21CR

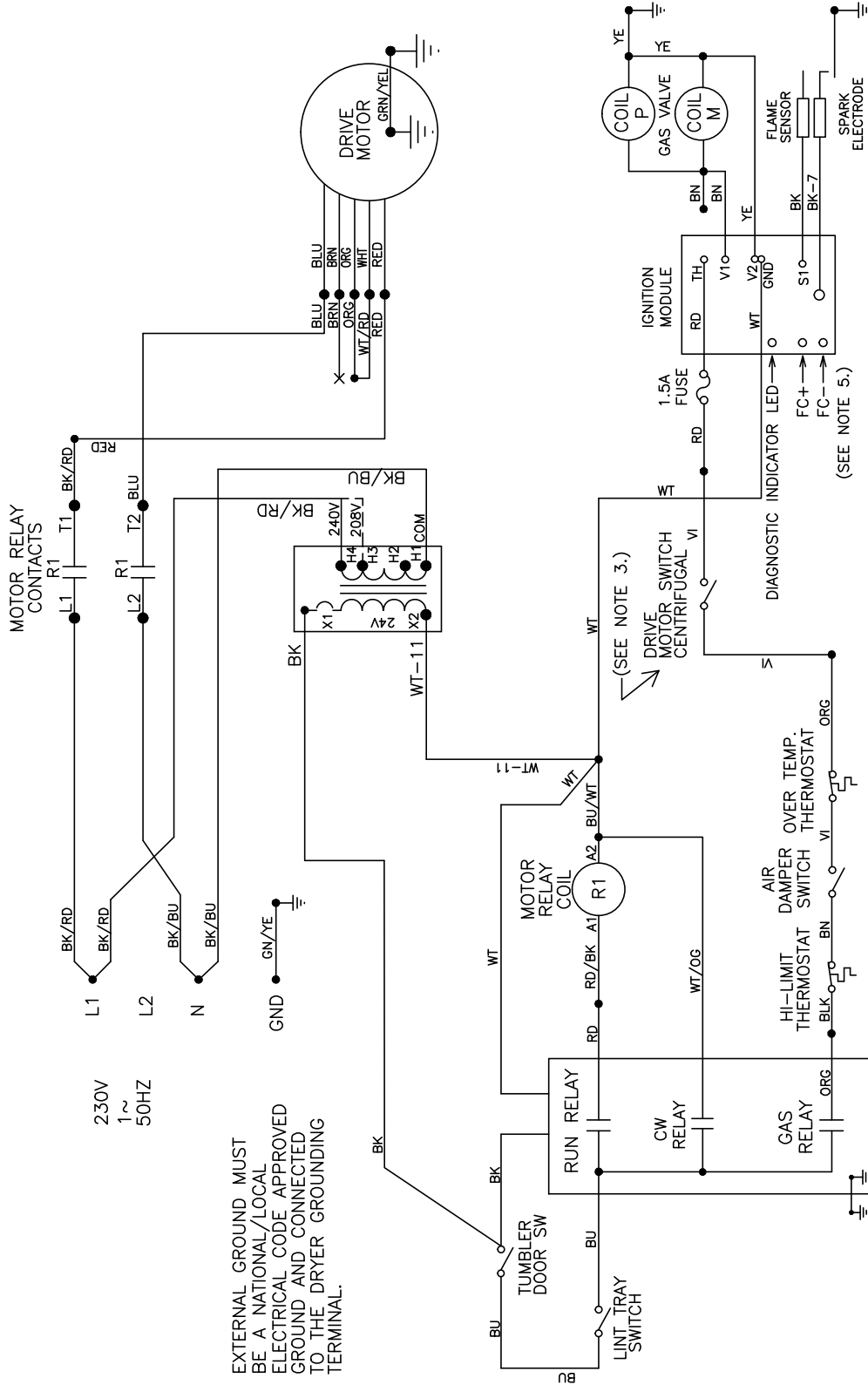

NOTES:

1. DOOR SWITCHES-N.O., CLOSED WHEN DOORS ARE CLOSED.
2. DRYER STARTS WHEN THE DOORS ARE CLOSED, A CYCLE IS SELECTED, AND THE START BUTTON IS PUSHED. THERE IS AN AUTOMATIC COOL DOWN AT THE END OF THE CYCLE.
3. CENTRIFUGAL SWITCH-N.O., CLOSURES WHEN MOTOR IS UP TO SPEED.
4. REFER TO OWNER'S MANUAL FOR DESCRIPTION OF OPERATION AND REQUIREMENTS FOR HEATING CIRCUIT.
5. WITH A DC MICROAMMETER, FLAME CURRENT CAN BE MEASURED AT TEST POINTS. READING SHOULD BE 0.7uA DC OR HIGHER.

CAUTION: LABEL ALL WIRES PRIOR TO DISCONNECTION WHEN SERVICING CONTROLS. WIRING ERRORS CAN CAUSE IMPROPER AND DANGEROUS OPERATION. VERIFY PROPER OPERATION AFTER SERVICING.

ATTENTION: AU MOMENT DEL'ENTRIEN DES COMMANDES, ETIQUETEZ TOUS LES FILS AVANT DE LES DEBRANCHER. DES ERREURS DE CABLAGE PEUVENT ENTRAINER UN FONCTIONNEMENT INADEQUAT ET DANGEREUX. S'ASSURER QUE L'APPAREIL FONCTIONNE ADEQUATEMENT UNE FOIS L'ENTRIEN TERMINE.

Wiring Diagram for Dryer 50hz 230V

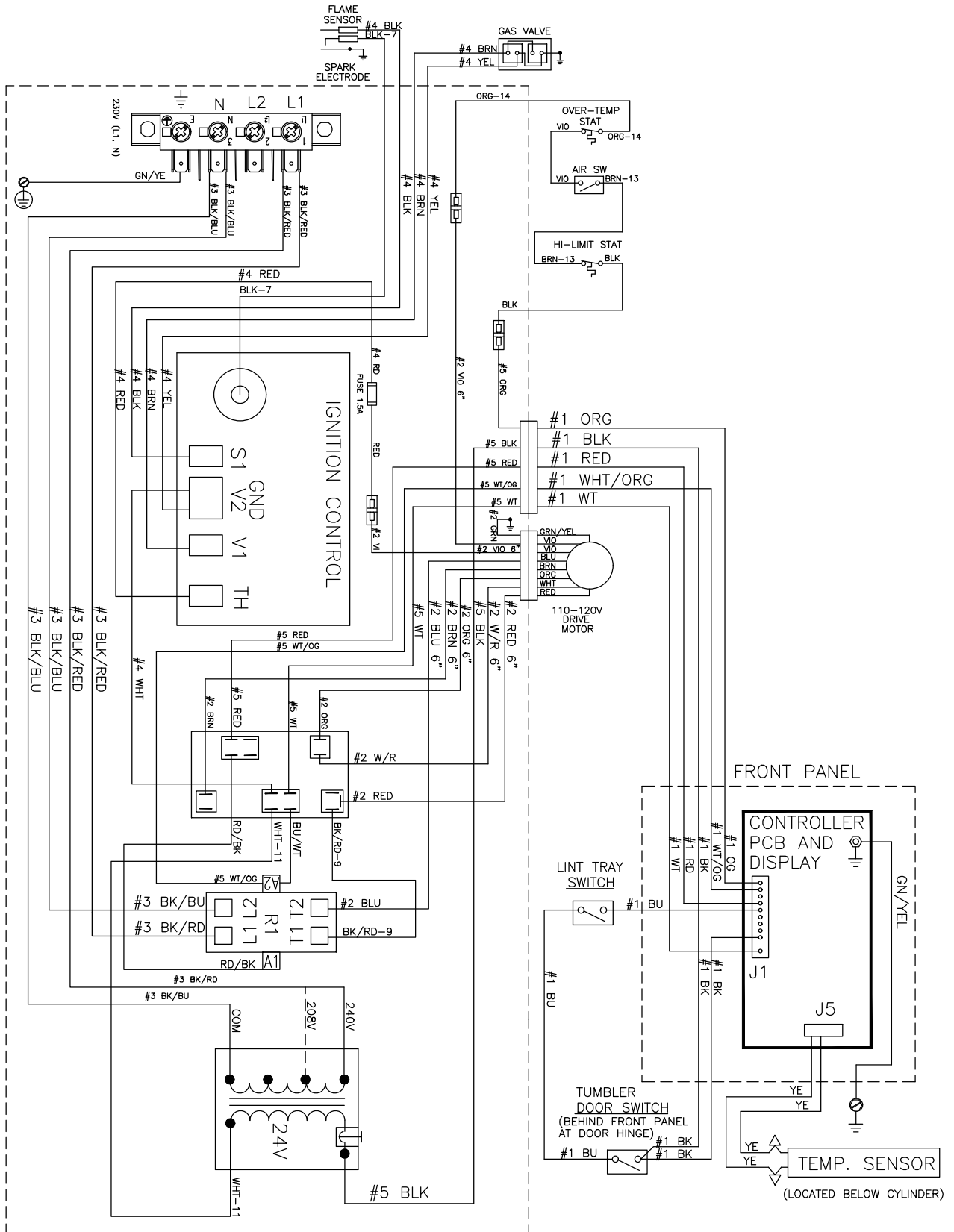

9506-823-001PR WIRING DIAGRAM DNS020N_-39_B_X-____-__X

IMPORTANT: RETAIN THIS ELECTRICAL DIAGRAM FOR SERVICE.



Section: 8

Electric Dryer Parts

Key	Description Electric Dryer Parts	Part Number	Qty
1	RELAY	5192-285-004	1
2	RELAY-HEATERS,60AMP	5192-296-001	1
3	CIRCUITBREAKER-3POLE	8220-057-016	1
4	INFORMATIVE-DNS020E_-(84/85)_B	8220-057-021	1
5	WIREASY-BLK,26"	8220-057-023	1
6	WIREASY-BLK,#33,8"	8220-057-031	3
7	WIREASY-WHT,#14,51/2"	8220-057-032	1
8	WIREASY-BLK,#18,91/2"	8220-061-011	3
9	WIREASY-BLK,36"	8220-063-020	1
10	WIREASY-RED,36"	8220-078-014	1
11	WIREASY-BLK,#19,17"	8220-078-024	3
12	WIREASY-WHT/BLK,#12,65"	8220-095-023	1
13	WIREASY-BLK,#15,22"	8220-103-002	1
14	WIREASY-BRN,#7,54"	8514-289-001	1
15	WIREASY-RED,#8,19"	8527-152-001	1
16	LABEL-WARNING,HIGHVOLTAGE	8652-134-002	2
17	LABEL-WARNING	9049-078-001	1
18	LABEL-WARN,FIREHAZARD(FRENCH)	9058-026-001	1
19	LABEL-EXHAUSTWARNING,ENGLISH	9074-293-001	1
20	LABEL-EXHAUSTWARNING,FRENCH	9074-294-001	1
21	LABEL-WARNINGFOR208V	9114-044-001	1
22	LABEL-DRYERLINT,ENGLISH	9114-045-001	1
23	LABEL-DRYERLINT,FRENCH	9114-046-001	1
24	LABEL-WIRING,INDIVIDUALBRANCH	9185-007-001	1
25	MANUAL-OPERATORS,DNS020E	9208-142-001	1
26	DECAL-CLEARANCE	9277-041-014	1
27	NUT-HEXKEPS,1/4-20UNC,2B	9295-004-002	3
28	TERMINAL-GROUNDING	9295-005-002	1
29	TERMINAL-LUG,SOLDERLESS	9377-003-001	1
30	BAFFLE-HEATERHOUSING	9452-824-001	1
31	BUSHING-INSULATED,3/4"	9454-944-001	3
32	BOTTOM-HOUSING,HEATER	9471-016-003	1
33	COVER-CONTROL HEATER	9488-011-002	1
34	COVER-HEATER	9538-049-002	1
35	DEFLECTOR-BOTTOM ELECTRIC HSG	9545-031-005	1
36	DEFLECTOR-WRAPPER,ELECTRIC HSG	9545-045-002	1
37	FILLER-COVER TERMINAL	9545-045-008	1
38	GUARD-TOP ELECTRIC HEATER	9551-030-001	1
39	JUMPER-FORMED	9551-031-001	1
40	JUMPER-STRAIGHT		2

Key	Description Electric Dryer Parts	Part Number	Qty
41	VARISTOR-COILSUPPRESSOR	9377-003-001	1
42	PLATE-COVER,RECIRCULATION	9452-824-001	1
43	PLUG-PLASTIC,7/8"	9456-041-006	3
44	PCBASY-CONTROLLER,OPLDRY-ELECT	9471-016-003	1
45	RAIL-DIN,35X15MM	9488-011-001	0.25
46	RAIL-DIN,35X15MM	9488-011-002	1
47	WIRINGLABEL-SCHEMATIC/DIAGRAM	9506-835-001	1
48	SPACER-METAL	9538-166-006	2
49	SCREW-HXHDCAP,1/4-20X3/4	9545-018-014	3
50	SCREW-PNHDCR,6BX3/8	9545-031-005	2
51	SCREW-HXWSHDSLTD,8BX1/2	9545-045-002	6
52	SCREW-HXWSHD,8ABX3/8	9545-045-008	6
53	SUPPORT-WIRE	9548-283-001	1
54	SHIELD-HEATINGELEMENTS	9550-197-001	1
55	SIDE-CONTROL,HEATER	9551-040-001	2
56	SIDE-HOUSING,HEATER,RH	9551-063-001	1
57	SIDE-HOUSING,HEATER,LH	9551-064-001	1
58	STRIP-MARKER,TERMINAL	9558-029-006	1
59	WIREHARNES-OVERTEMP/AIRSWITCH	9627-861-002	1
60	WRAPPER-HOUSING,HEATER	9636-217-001	1
61	WRAPPER-CONTROL	9636-218-001	1
62	CONTROLASSY-OPL,NONREV,ELEC	9857-227-003	1
63	CNTROLASY-T20SWD,ELEC,OPL84/85	9857-232-003	1
64	CONTROLSASSY-ELEC/HTR,-84	9857-252-001	1
65	HEATER-ELEMENT,10KW,208V,STK	9870-093-002	2
66	TERMINALBLOCKASSEMBLY-POWER	9897-026-001	2
67	BLOCK-POWER,3POLE	9897-037-001	1
68	BLOCK-POWER,1POLE	9897-038-001	1

Key	Description Additional Parts for -85 240 / 60 / 3 / 4 wire + ground 15 kW Electric	Part Number	Qty
*	CIRCUITBREAKER-3POLE	5198-213-003	1
*	CONTROLSASSY-ELEC/HTR,-85	9857-252-002	1
*	HEATER-ELEMENT,10KW,240V,STK	9870-093-001	2

Key	Description Additional Parts for -82 400 / 50 / 3/ 4 wire + ground 15 kW Electric	Part Number	Qty
1	RELAY-HEATERS,60AMP	5192-291-001	1
2	CIRCUITBREAKER-3POLE	5198-213-004	1
3	INFORMATIVE-DNS020E_-(84/85)_B	6102-018-366	1
4	WIREASY-BLK,26"	8220-001-499	1
5	WIREASY-RED,36"	8220-057-032	1
6	LABEL-WARN,FIREHAZARD(FRENCH)	8502-702-001	1
7	LABEL-EXHAUSTWARNING,ENGLISH	8502-708-001	1
8	LABEL-EXHAUSTWARNING,FRENCH	8502-708-002	1
9	LABEL-WARNINGFOR208V	8502-711-001	1
10	LABEL-DRYERLINT,ENGLISH	8502-727-001	1
11	LABEL-DRYERLINT,FRENCH	8502-727-002	1
12	JUMPER-FORMED	9295-004-002	1
13	JUMPER-STRAIGHT	9295-005-002	2
14	PULLEY-MOTOR,60HZ	9453-185-001	1
15	WIRINGLABEL-SCHEMATIC/DIAGRAM	9506-835-001	1
16	STRIP-MARKER, TERMINAL	9558-029-006	1
17	CNTROLASY-T20SWD,ELEC,OPL84/85	9857-232-003	1
18	CONTROLSASSY-ELEC/HTR,-84	9857-252-001	1
19	HEATER-ELEMENT,10KW,208V,STK	9870-093-002	2

