



DCBD120HC_-10BD

Section 5: Dryer Parts Data

Dryer Cabinet Front Panel

Key	Description	T-120	
*	Loading Door Complete Wht/Brushed SS/Blk	9960-305-003	1
1	Door Assy, Loading (Ring only) Brushed SS	9960-284-002	1
2	Plate Assy, Hinge (Wht)	9982-368-003	1
*	Cover-Hinge Back, Black	9074-340-002	1
*	Screw-10Bx3/8, Black	9545-008-010	2
*	Screw Hinge to Door	9545-012-015	4
*	Nut, Hinge to Door	8640-413-002	4
3	Glass, Door	9212-002-004	1
4	Gasket, Door Glass (Black)	9206-413-002	1
*	Support Door Glass	9545-117-000	2
5	Gasket, Door Outer Rim (Black)	9206-420-005	1
6	Handle, Loading Door	9244-082-001	1
*	Screw, Handle	9545-018-017	2
7	Stud Door Catch 7/8"	9531-033-003	1
8	Nut-Hex, #10-32	8640-413-001	1
9	Nut, Acorn	8640-413-003	1
*	Catch, Loading Door	9086-015-002	2
*	Rivet	9491-009-004	2
10	Strap, Hinge (Black)	9966-014-002	1
*	Chanel Assy.-Front Panel	9947-024-001	1
*	Screw-Phillips, 10-32x1/2 Chrome	9545-012-028	4
*	Screw-Phillips-Counter sink, 10-32x1/2 Chrome	9545-012-003	2
11	Screw-Special, Hinge to Door	9545-052-001	1
*	Nut-Allen, 1/4-20	8640-439-001	1
12	Washer-Fiber/Plastic	8641-436-003	1
13	Front Panel Assy (Wht)	9989-546-001	1
14	Screw-Phillips, 10Bx1 3/4	9545-008-014	10
15	Washer-Finish	8641-585-001	10
*	Nut-Spring	8640-399-001	10
16	Screw-Torx, 10AB x 3/4", White "T-20"	9545-008-035	8
*	Insulation-Front Panel	9277-060-001	1
17	Label-Warning	8502-753-001	1
18	Plug-Front Panel, Optional Door Switch Location	9456-050-001	1
*	Switch-Door Closed	9539-492-001	1
*	Wire-Assy-Blk, 23"	8220-063-028	1
*	Wire-Assy-Red, 23"	8220-063-029	1
19	Plug, 1/4", Locking	9456-051-001	6
*	Plug-2"	9456-041-009	1
20	Switch Assembly-Membrane	9801-103-001	1
21	Box-Control	9041-107-002	1

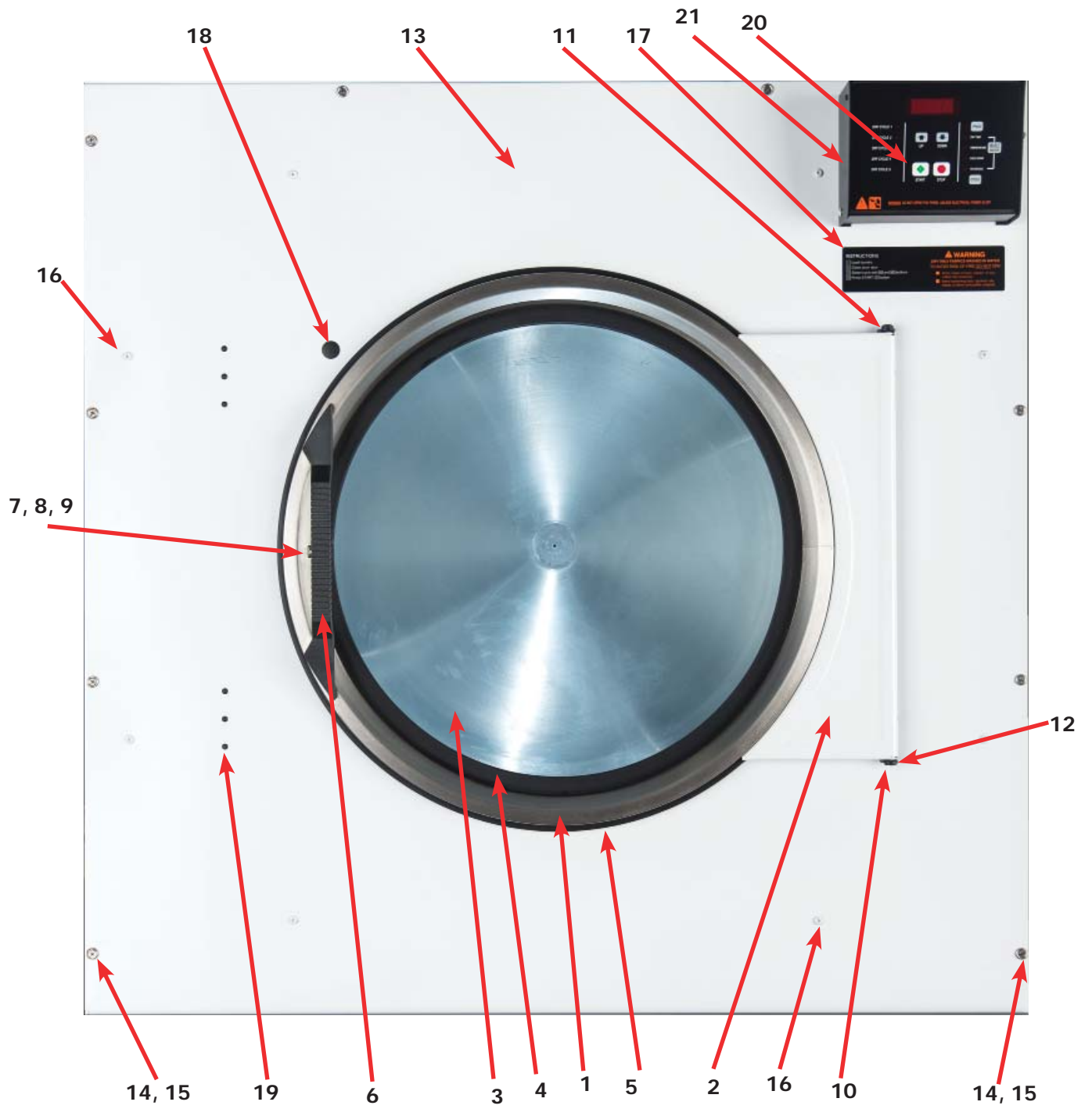

Dryer Cabinet Group Continued

Key	Description	T-120	QTY
1	Nameplate - Dexter Dryer Black	9412-196-001	1
2	Door Assy-Upper, OPL (Wht)	9454-884-002	1
3	Screw-Phillips, 10Bx1 3/4	9545-008-014	4
4	Washer-Finish	8641-585-001	4
*	Nut-Spring	8640-399-001	4
5	Box-Control Front, Black	9041-107-002	1
6	Screw-5/16, 10ABx3/8	9545-008-024	4
7	Screw-10-32 x 1/2, Chrome	9545-012-003	2
8	Plate Assembly-Meter, Black	9982-379-002	1
9	Nut-Elastic Stop, #10-32	8640-413-004	2
10	Spacer-#6 x 1/2	9538-157-016	4
11	Kit-OPL Reversing, PCB-Controler	9732-249-001	1
12	Nut, #6-32	8640-411-001	3
13	Wire Assy-GRN, 12"	8220-060-001	1
14	Nut, #6-32	8641-411-003	1
15	Screw, #10-32 x1/2 Green	9545-008-027	1
16	Lock Washer #10	8641-582-006	1
17	Fuse, .600MA/250V	8636-024-001	1
18	Membrane Switch	9801-103-001	1
19	Screw Torx-6BSD x 1/2, BLK, "T10"	9545-031-009	2
20	Harness-Control	9627-770-002	1
21	Harness-Temp Probe	9627-679-002	1
22	Plug-2"	9456-041-009	1
23	Label-Warning	8502-753-001	1

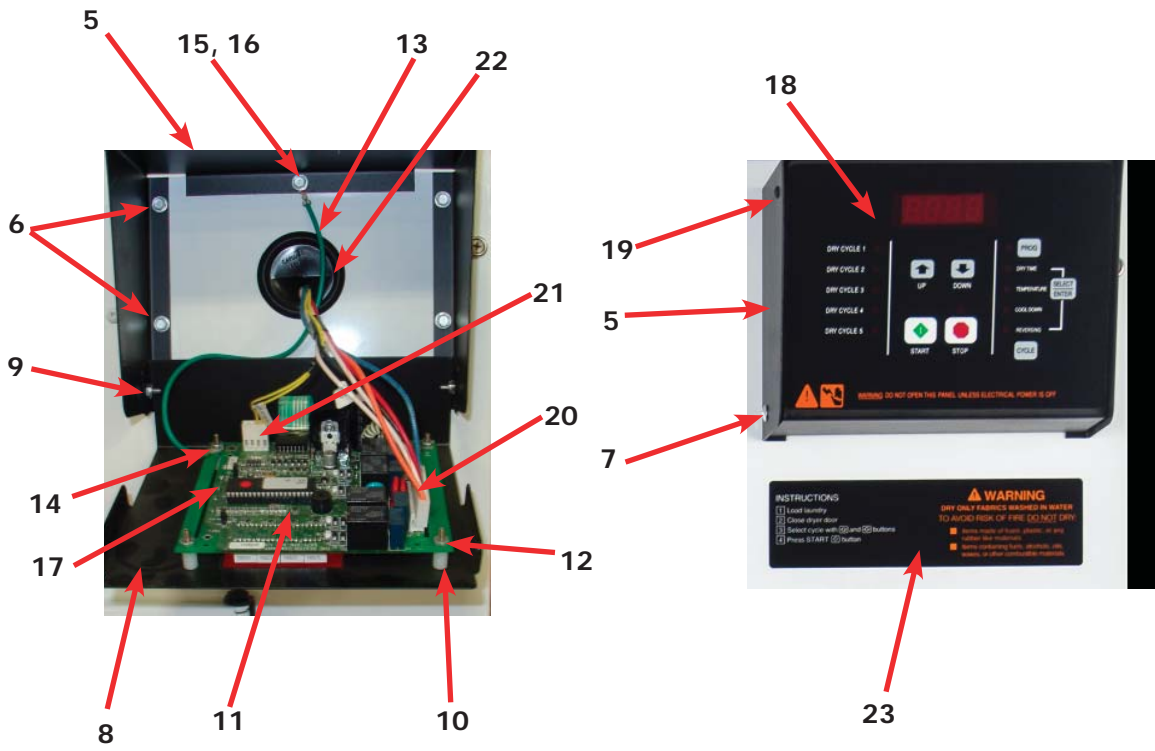
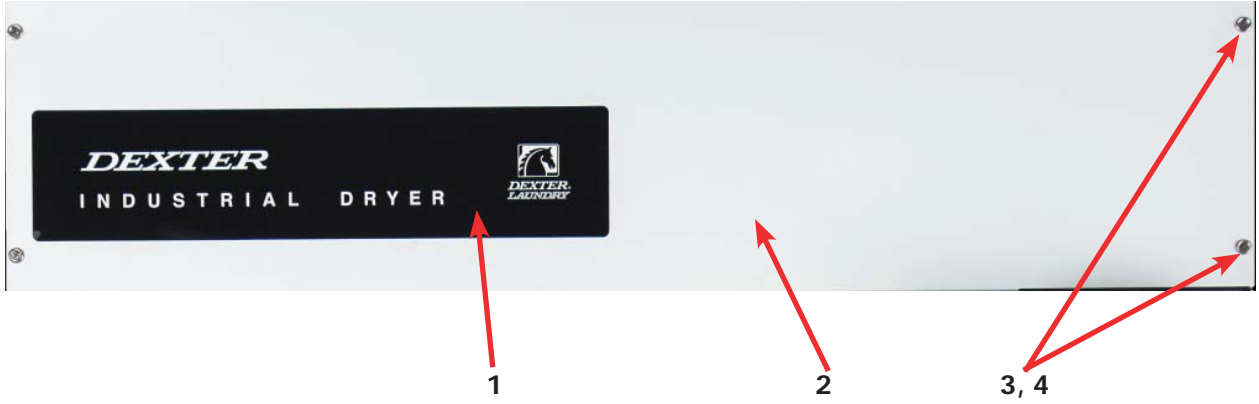

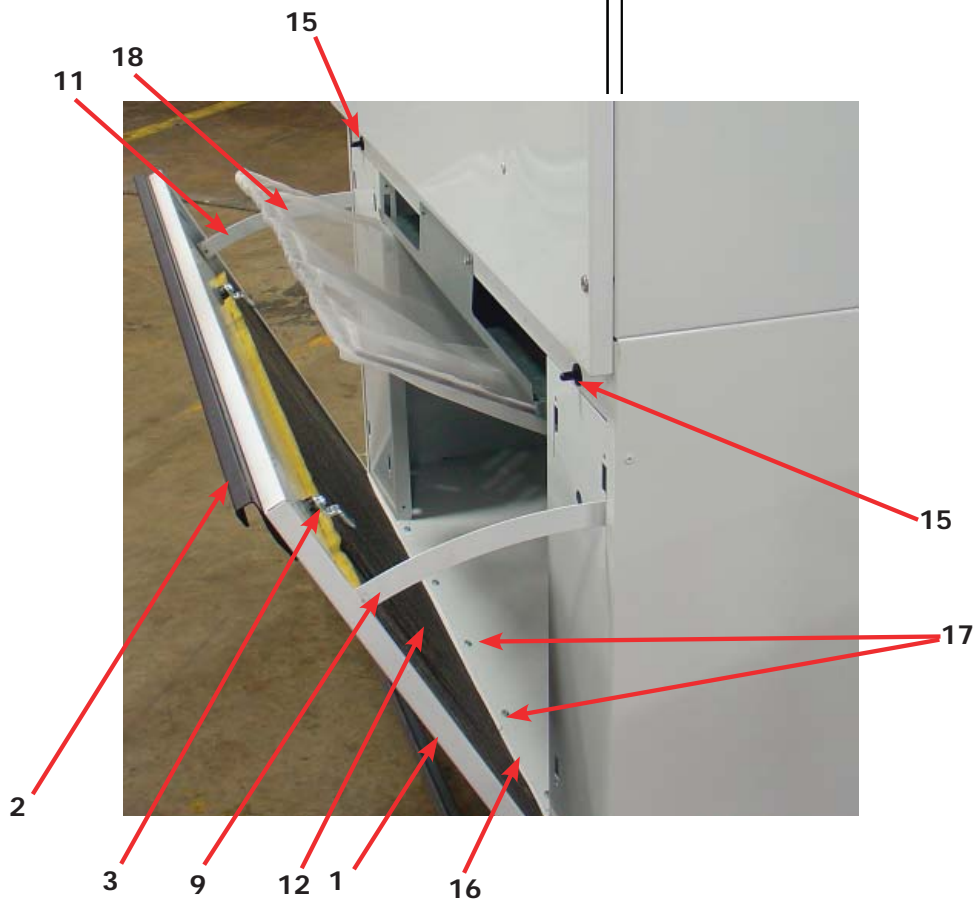
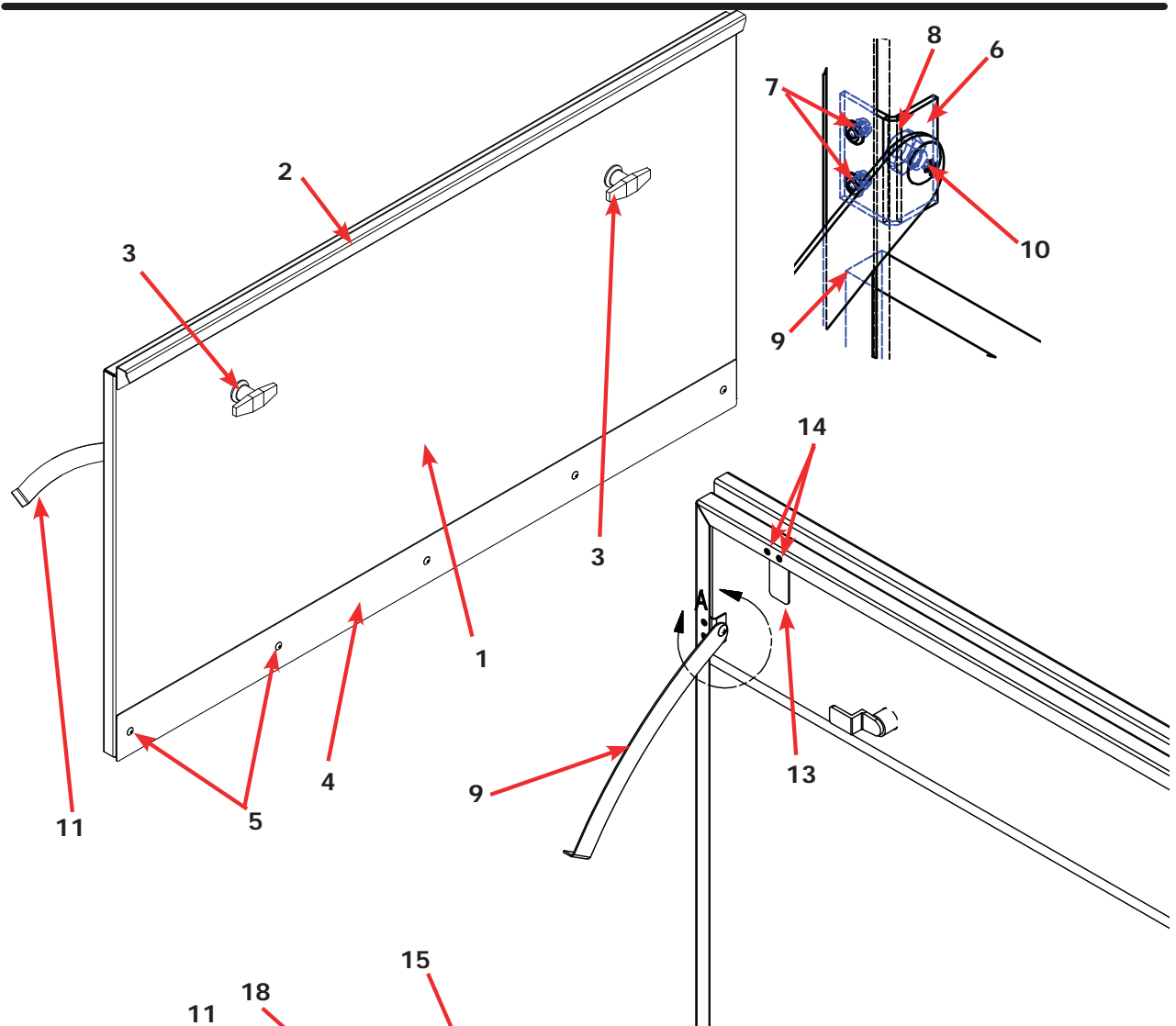

Dryer Cabinet Group Continued

Key	Description	T-120	QTY
1	Panel Assy.-Upper Right	9989-549-002	1
*	Screw, 5/16- 10ABx3/8	9545-008-024	2
2	Insulation-Right Upper, Burner Area	9277-041-002	1
3	Panel Assy.-Upper Left	9989-550-002	1
*	Screw, 5/16- 10ABx3/8	9545-008-024	2
4	Insulation Tumbler Area, Right (Front & Back)	9277-051-005	2
4	Insulation Tumbler Area, Right (Center)	9277-051-006	1
5	Insulation Tumbler Area, Left (Front & Back)	9277-051-005	2
5	Insulation Tumbler Area, Left (Center)	9277-051-006	1
6	Switch-Door Closure	9539-492-001	2
*	Screen Assy, Lint	9822-033-001	1
*	Lint Hood Assembly	9834-011-001	1
7	Lint Hood, Top & Sides	9240-047-001	1
8	Lint Hood, Bottom	9058-028-001	1
9	Lint Hood, Angle	9003-333-001	1
10	Screw, 5/16- 10ABx3/8	9545-008-024	21
11	Hinge-Door, Lower	9243-083-002	1
*	Screw-5/16, 10ABx3/8	9545-008-024	5
12	Impeller, w/set screws	9278-041-001	1
13	Harness -Temp Probe	9627-679-002	1
14	Wire Nut, #71B	8640-276-005	2
15	Temp Probe	9501-004-002	1
16	Screw-Phillips, 8Bx1/4	9545-045-005	1
17	Bracket, Temp Probe	9029-111-001	1
18	Screw, 8AB x 3/8	9545-045-008	2
19	Trim-Edge, Lint Hood	9578-092-003	2

120Lb. Temp Probe

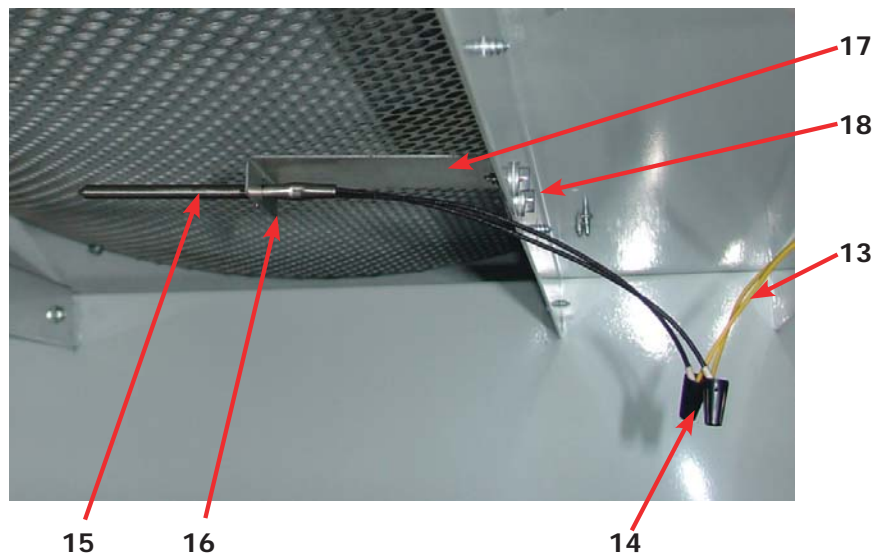

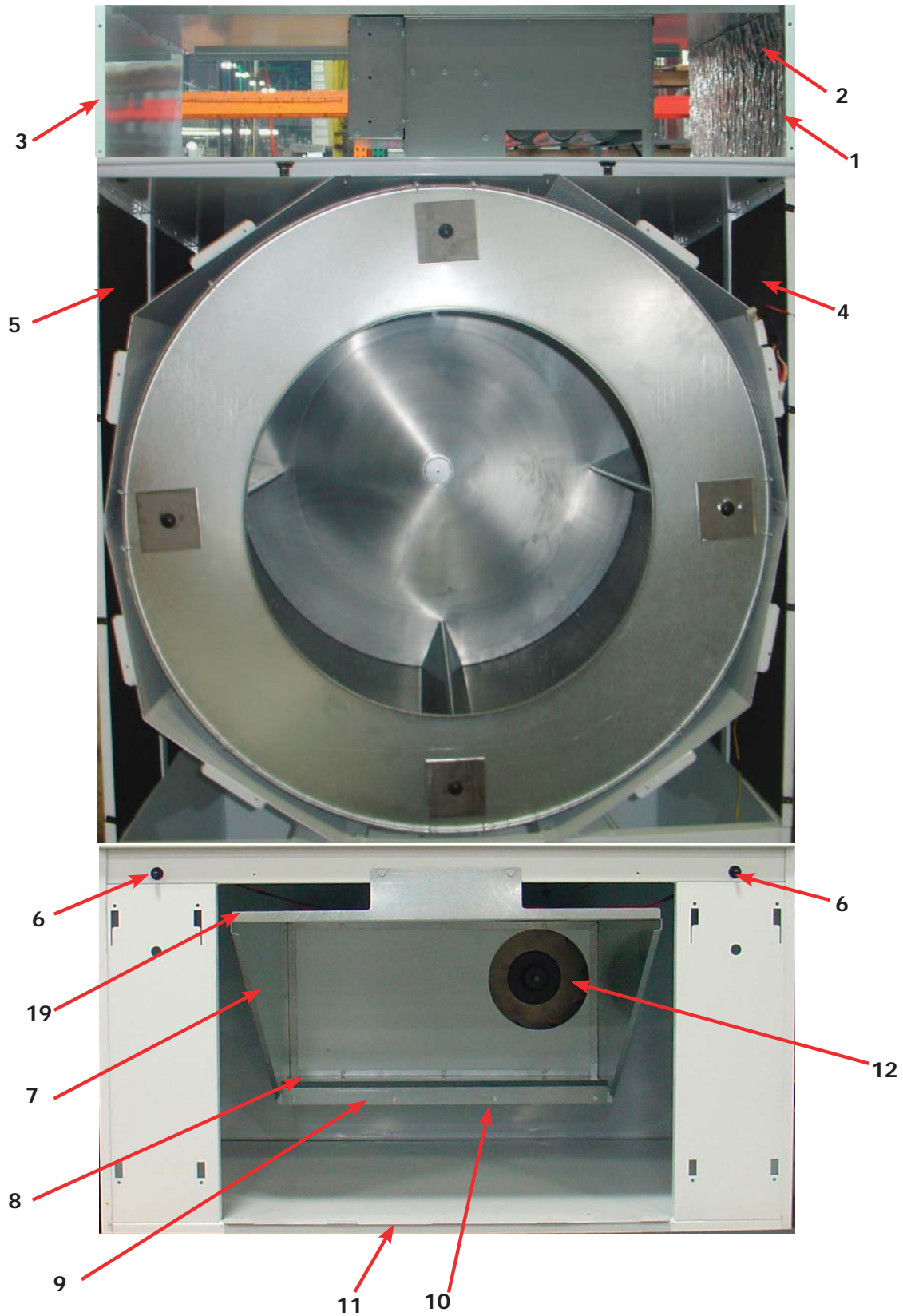

Dryer Rear View 120Lb Reversing

Key	Description	T-120	QTY
1	Pulley, Driven	9453-168-003	1
2	Tolerance Ring	9487-234-006	1
3	Washer -Flat	8641-581-032	1
4	LockWasher - IntTooth, 1"	8641-582-018	1
5	Screw, 5/8-11 x 1 1/2	9545-060-001	1
6	Belt-Driven	9040-076-005	2
*	Impeller, 5" x 16"	9278-041-001	1
7	Plate Assembly-Impeller	9982-375-002	1
8	Nut-Wiz Lock, 5/16-18	8640-400-003	6
*	Gasket-Impeller Housing	9206-428-002	1
9	Motor-Blower	9376-317-005	1
10	Screw, 5/16-18 x 5/8	9545-014-004	4
11	Nut-Wiz Lock, 5/16-18	8640-400-003	4
12	Thermostat-Overtemp	9576-207-006	1
13	Screw-10AB x 3/8	9545-008-006	2
14	Pulley, Intermediate, w/Bearings	9908-051-001	1
*	Bearings-Ball	9036-159-011	2
*	Spacer-Bearings	9538-186-001	1
*	Ring-Retaining, Internal	9487-238-006	1
15	Washer-Flat	8641-581-039	1
16	Nut, 5/8-11	8640-425-002	1
17	Belt, Motor	9040-076-008	1
18	Motor, Drive	9376-307-003	1
19	Pulley-Motor	9453-169-012	1
20	Bushing, Motor -Support	9053-074-002	2
21	Rod-Motor Mounting, Black	9497-222-008	1
22	Collar-Shaft, w/Set Screws	9076-052-002	1
23	Chain-Belt tension	9099-012-004	1
*	Hook-S Type	9248-022-002	1
24	Spring, Belt Tension	9534-151-000	1
25	Duct-Transition, 12" to 10"	9109-124-001	1

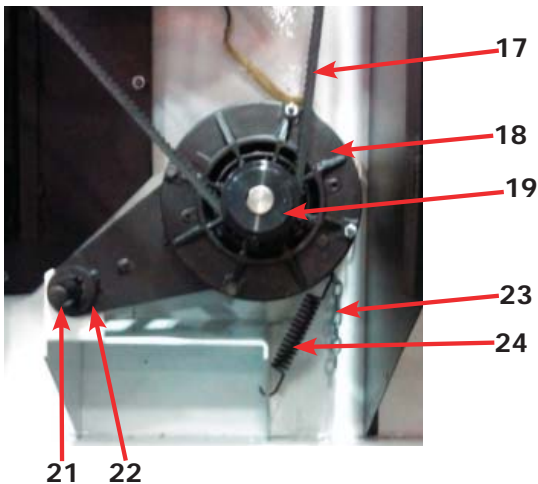

Dryer Rear View 120Lb Reversing

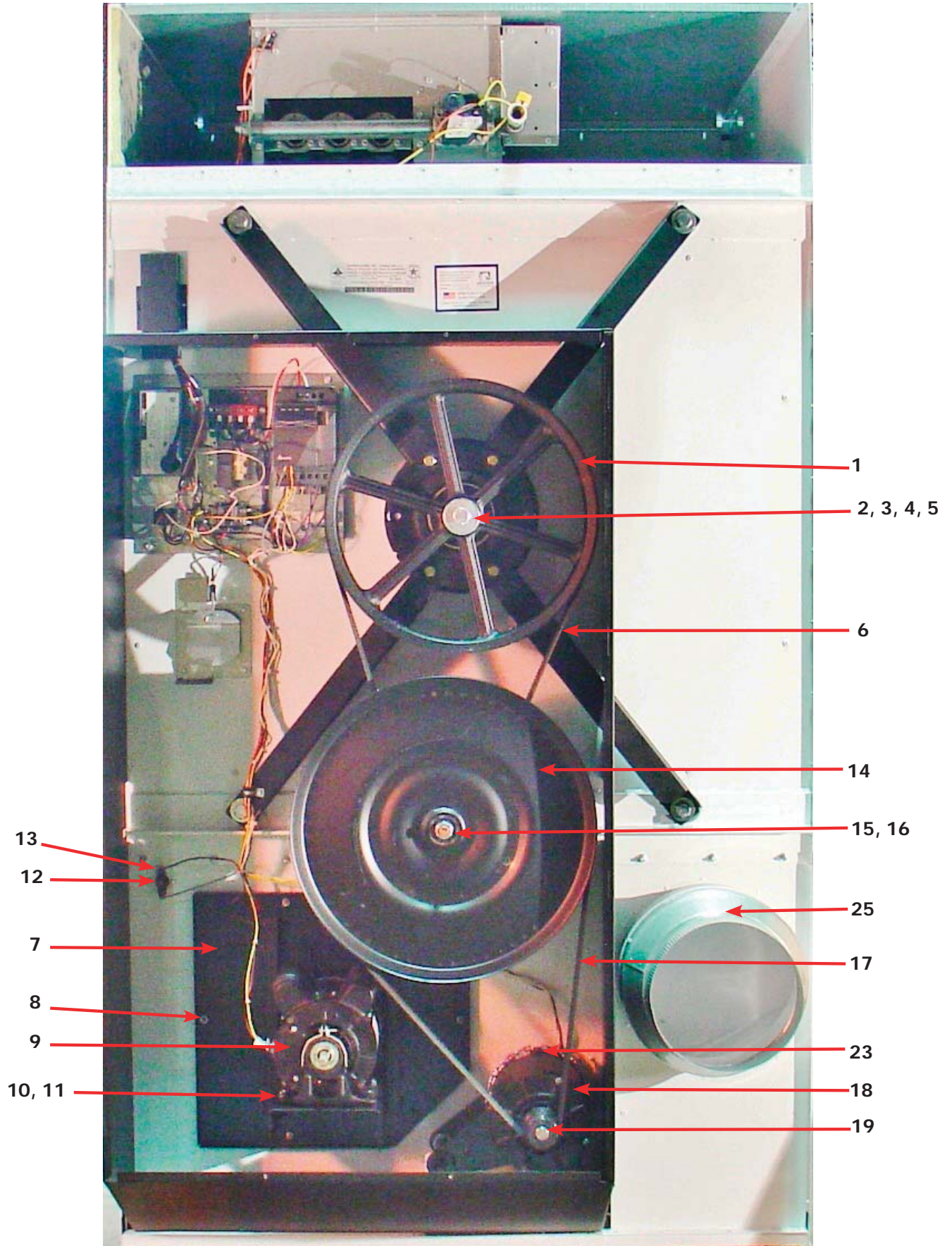

Dryer Rear View 120Lb Reversing Continued

Key	Description	T-120	QTY
1	Pulley, Driven	9453-168-003	1
2	Tolerance Ring	9487-234-006	1
3	Washer -Flat	8641-581-032	1
4	LockWasher - IntTooth, 1"	8641-582-018	1
5	Screw, 5/8-11 x 1 1/2	9545-060-001	1
6	Plate Assembly-Intermediate, Tension	9982-378-002	1
7	Rod-Intermediate, Pivot	9497-230-002	1
8	Collar, Locking	9076-060-001	1
9	Bolt, 1/2-13 x 1 1/2	9545-017-001	2
10	Thermostat-Overtemp	9576-207-006	1
11	Screw-10AB x 3/8	9545-008-006	2
*	Impeller, 5" x 16"	9278-041-001	1
12	Plate Assembly-Impeller	9982-375-002	1
13	Nut-Wiz Lock, 5/16-18	8640-400-003	6
*	Gasket-Impeller Housing	9206-428-002	1
14	Motor-Blower	9376-317-005	1
15	Screw, 5/16-18 x 5/8	9545-014-004	4
16	Nut-Wiz Lock, 5/16-18	8640-400-003	4
17	Motor, Drive	9376-307-003	1
18	Pulley-Motor	9453-169-012	1
*	Bushing, Motor -Support	9053-074-002	2
19	Rod-Motor Mounting, Black	9497-222-008	1
20	Collar-Shaft, w/Set Screws	9076-052-002	1
21	Chain-Belt tension	9099-012-004	1
*	Hook-S Type	9248-022-002	1
*	Spring, Belt Tension	9534-151-000	1



7 8 6



9 6 9

Dryer Rear View 120Lb Reversing Continued

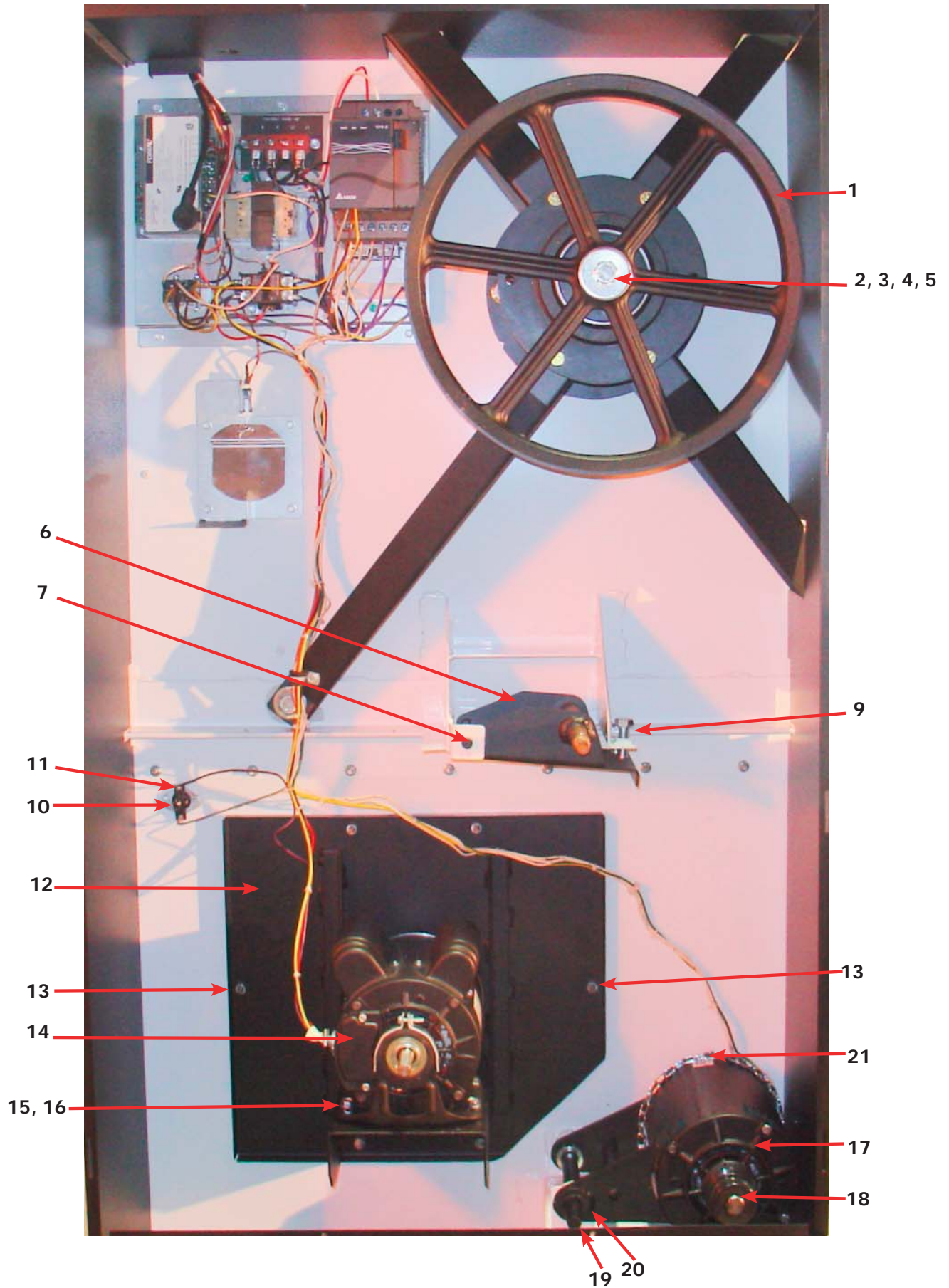

Dryer Rear View-Guard & Exhaust

Key	Description	T-120	QTY
1	Cover Cabinet	9074-356-001	1
*	Screw-5/16, 10ABx3/8	9545-008-024	16
2	Duct-Transition, 12" to 10"	9109-124-001	1
*	Screws-10-16 x 1/2	9545-008-003	3
*	Guard-Side, Right	9208-111-002	1
*	Screw-Torx T20, 10B x 3/8, BLK	9545-008-034	7
3	Guard-Side, Left	9208-110-002	1
*	Screw-Torx T20, 10B x 3/8, BLK	9545-008-034	8
4	Guard-Top	9208-112-002	1
*	Screw-Torx T20, 10B x 3/8, BLK	9545-008-034	11
5	Guard-Bottom	9208-113-002	1
*	Screw-Torx T20, 10B x 3/8, BLK	9545-008-034	6
6	Guard-Wires	9208-115-002	1
*	Screw-Torx T20, 10B x 3/8, BLK	9545-008-034	2
7	Guard-Door, Right	9208-114-004	1
*	Screw-Torx T20, 10B x 3/8, BLK	9545-008-034	6
8	Guard-Door, Left	9208-114-003	1
9	Screw-Torx T20, 10B x 3/8, BLK	9545-008-034	4
*	Nut-Spring, U-type	8640-399-001	4
*	Booklet-Owners	8514-215-001	1
10	Diagram & Schematics	9506-499-001	1
11	Label-Warning & Notice	8502-600-001	1
12	Label-Instructions	8502-645-001	1
13	Decal-Lighting & Clearance	8527-151-001	1
14	Label-High Voltage	8502-614-004	1

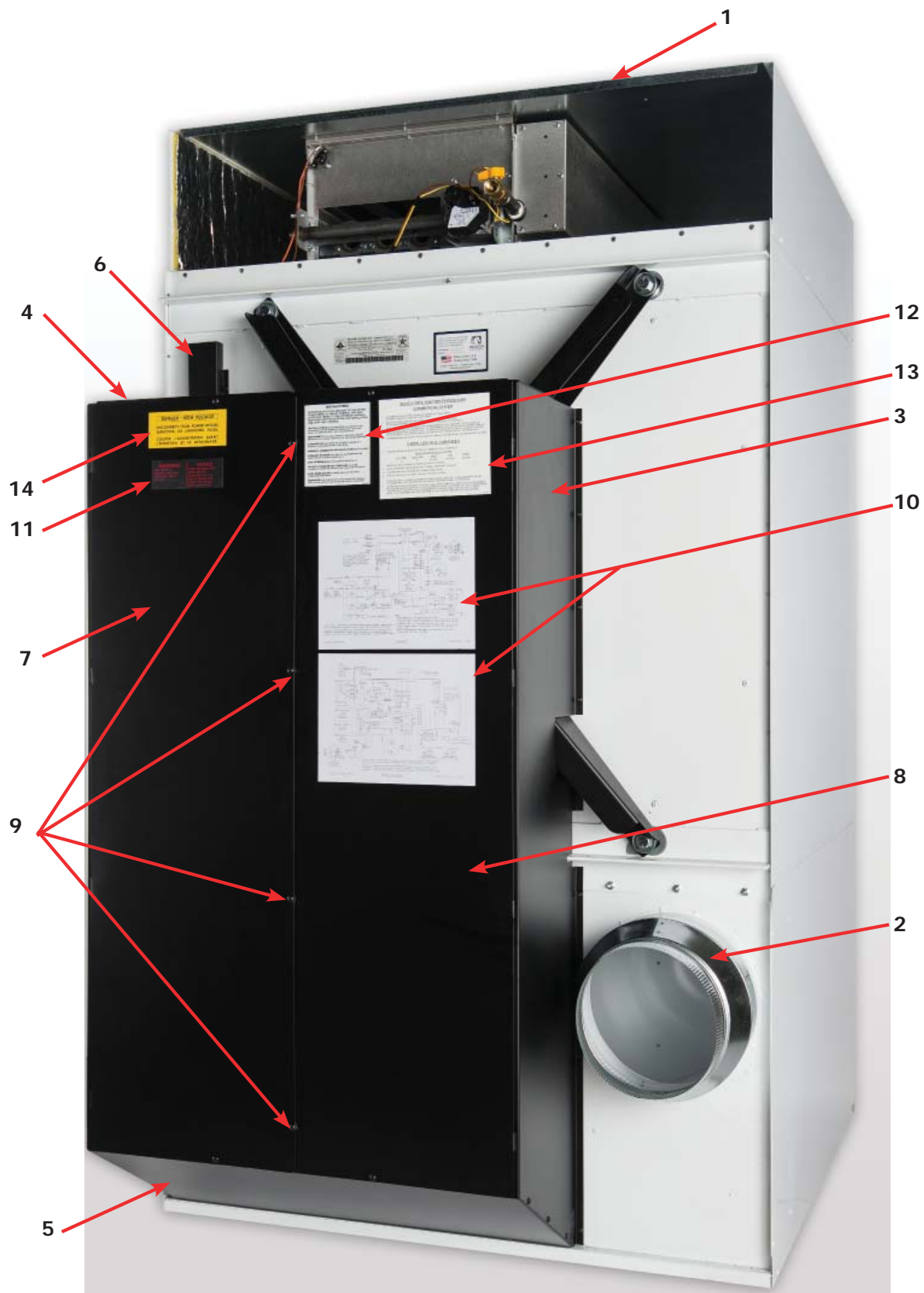

Dryer Rear View-Bearing Housing 120Lb

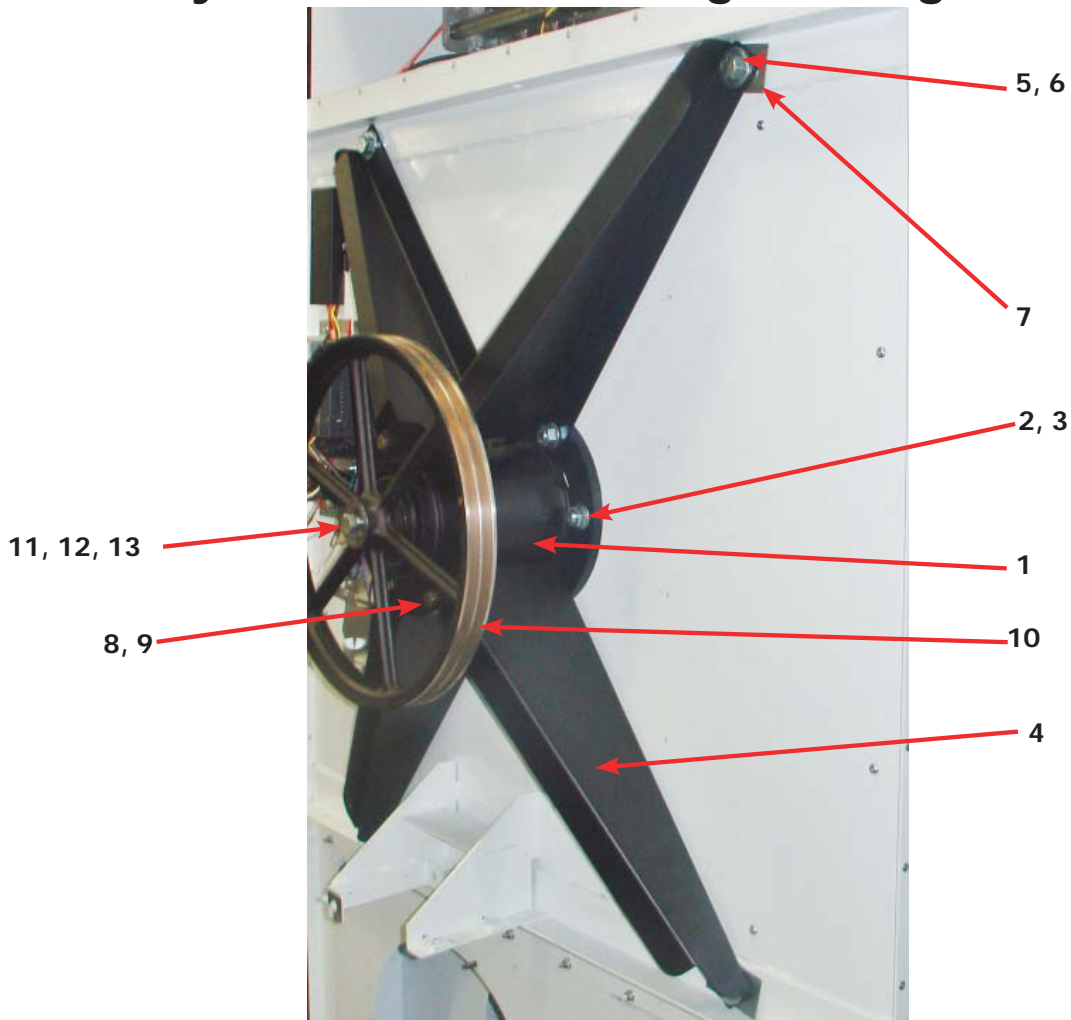

Key	Description	T-120	QTY
	Bearing Housing Complete Assy (Includes bearings & Spacer)	9803-186-001	1
1	Housing, Bearing	9241-180-002	1
*	Ring, Retaining-Internal	9487-238-003	1
*	Bearing, Ball, Front	9036-159-005	1
*	Spacer, Bearing	9538-167-001	1
*	Bearing, Ball, Rear	9036-159-004	1
*	Washer, Flat	8641-581-040	6
2	Screw-5/8"-11 x 1 1/2"	9545-060-001	6
3	Nut-Whizlock, 5/8" x 11	8640-425-001	6
4	Arm-Support Housing	9001-065-002	4
5	Screw-5/8-11 x 1 1/2	9545-060-001	4
6	Washer, Flat 5/8"	8641-581-038	4
7	Shim	9552-045-001	AR
8	Screw-7/16"-14 x 1 1/2"	9545-059-003	4
9	Nut-Whizlock, 7/16"	8640-416-005	4
*	Tolerance Ring	9487-234-006	1
10	Pulley Driven	9453-168-003	1
11	Washer, Flat 5/8" x 2 1/4"	8641-581-032	1
12	Lock Washer Spring, 1/2	8641-582-018	1
13	Screw, 5/8-11 x 1 1/2"	9545-060-001	1

Dryer Tumbler Group 80Lb

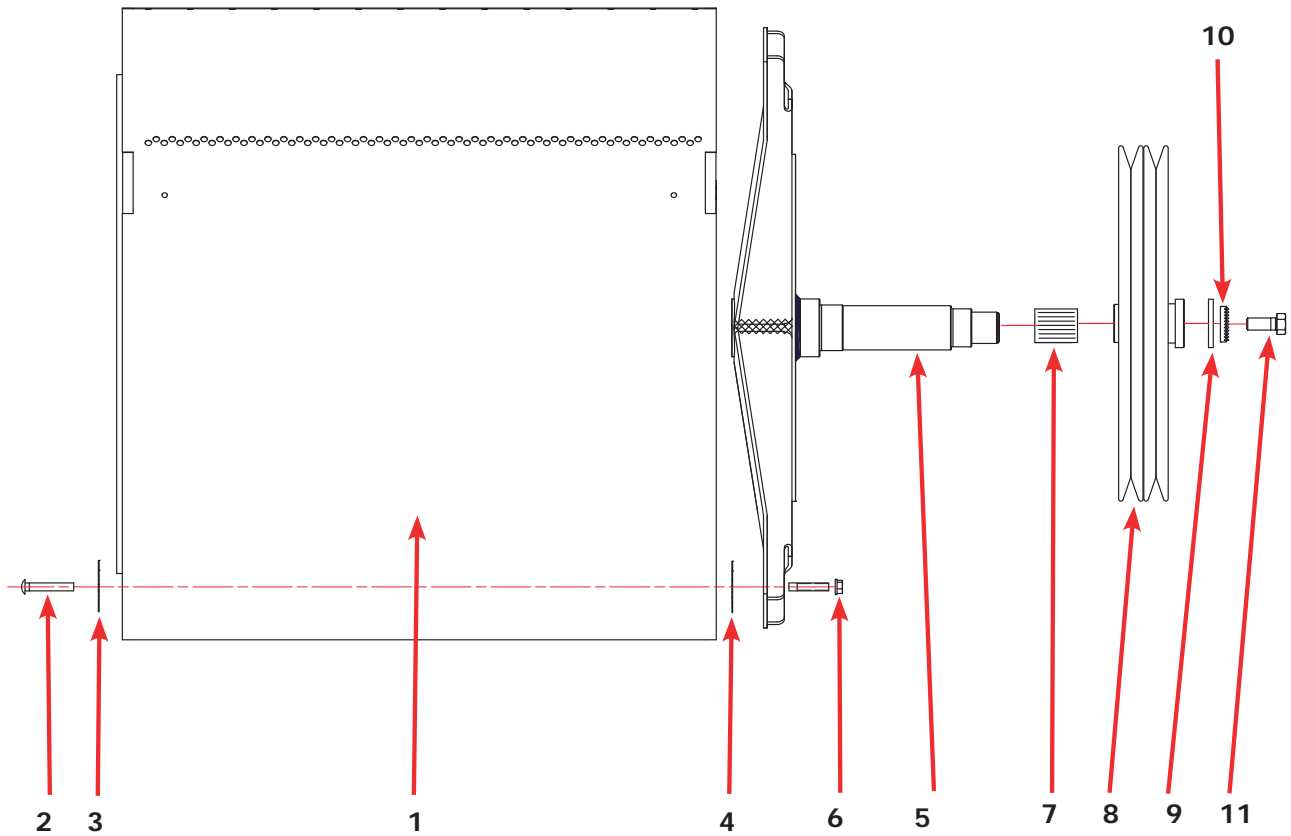

Key	Description	T-120	QTY
*	Tumbler Assy Complete W/Spider (GALV)	9848-144-001	1
1	Tumbler Assy (Galvanized)	9849-143-001	1
2	Rod, Tumbler	9497-266-003	4
3	Plate support, Tie Rod	9452-805-001	4
4	Shim	9552-013-000	AR
5	Spider Assy	9568-016-001	1
6	Nut, Wiz Lock	8640-417-005	4
7	Tolerance Ring	9487-234-006	1
8	Pulley, Driven	9453-168-003	1
9	Washer -Flat	8641-581-032	1
10	LockWasher - IntTooth, 1"	8641-582-018	1
11	Screw, 5/8-11 x 1 1/2	9545-060-001	1

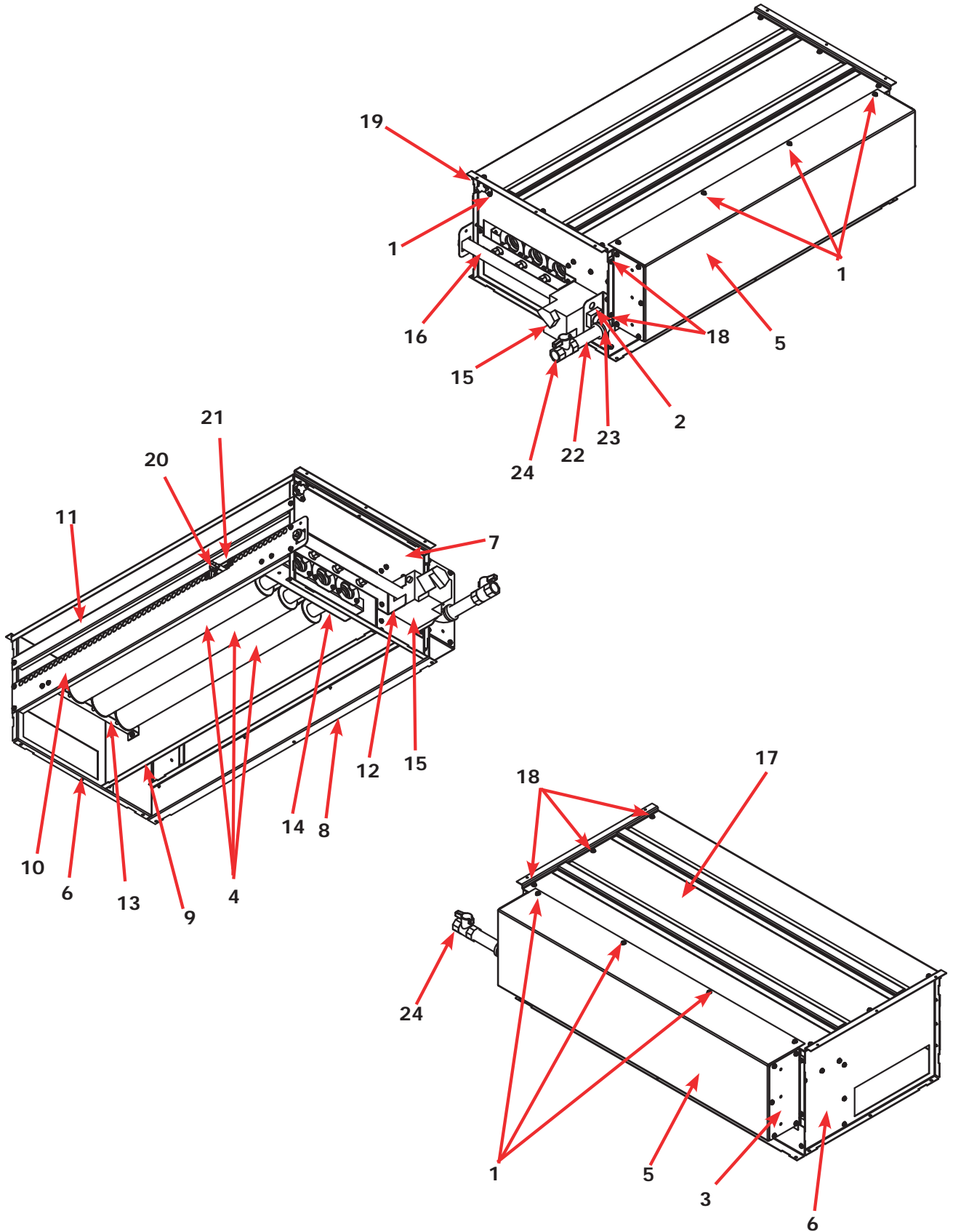

Dryer Air Flow Swwitch Assembly

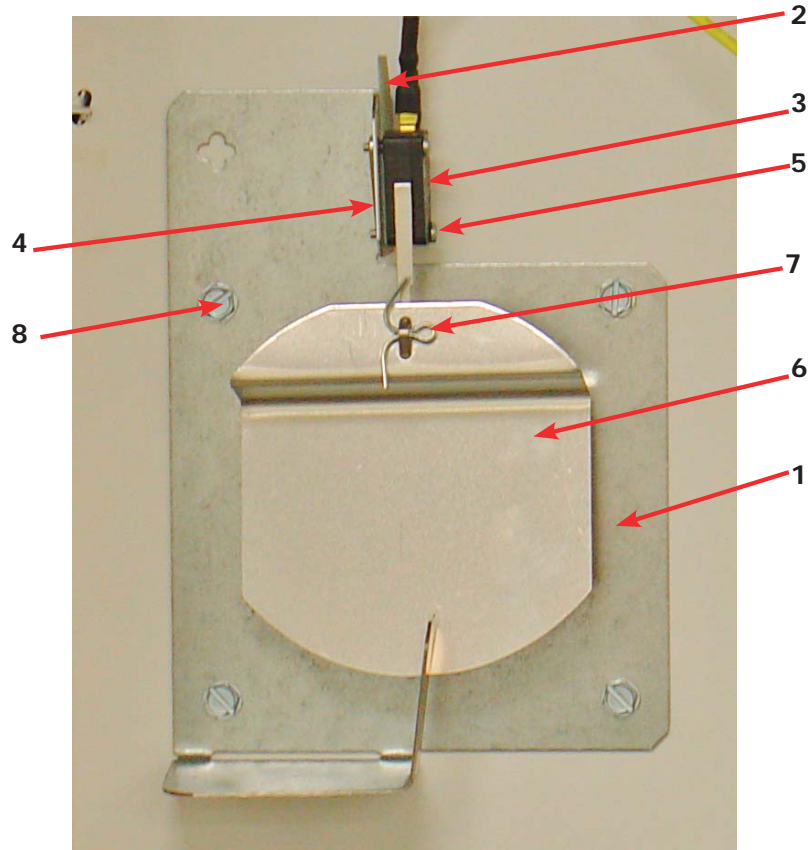

Key	Description	T-120	QTY
*	Air Flow switch Assy	9801-098-001	1
1	Bracket-Airflow switch	9029-200-001	1
2	Shield-Switch	9550-169-003	1
3	Switch-Micro	9539-461-009	1
4	Nut-Twin, 4-40	8640-401-001	1
5	Screw-.625, 4-40	9545-020-001	2
6	Actuator-Air Flow Switch	9008-007-001	1
7	Pin-Cotter, .09375x.75	9451-169-002	1
8	Screw, 10Bx1/4	9545-008-024	4

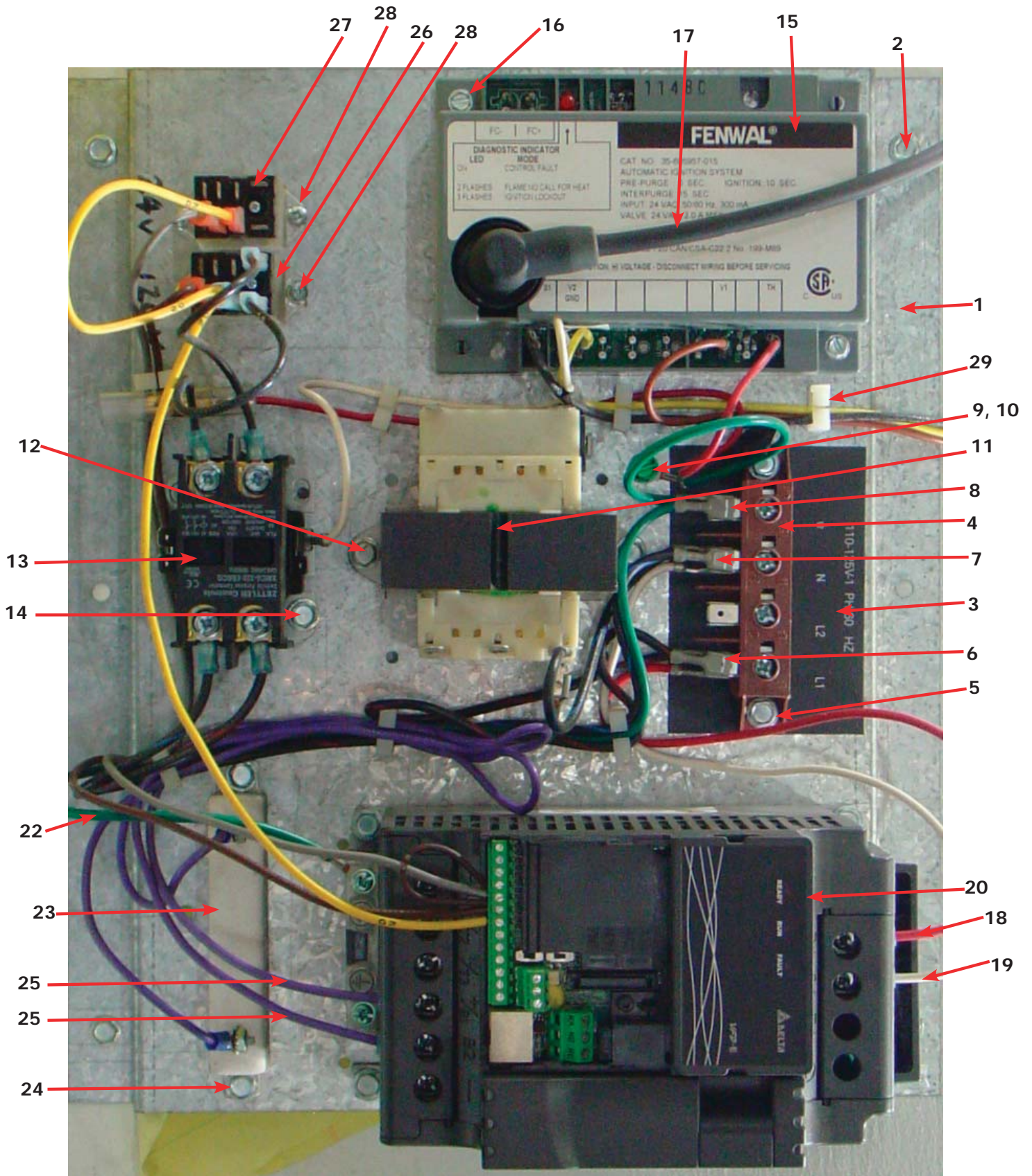

Dryer Rear View-Control Box

Key	Description	T-120	QTY
*	Control Assembly, (1 thru 28)	9857-195-001	
1	Channel-Controls	9081-163-001	1
2	Screw, 5/16-10AB-3/8	9545-008-026	6
3	Strip-Marker, Terminal	9558-029-005	1
4	Terminal Block Assy-Power, 4Pole	9897-035-001	1
5	Screw, 5/16-10AB-3/8	9545-008-024	2
6	Wire assy-Blk/Red, 8 1/2"	8220-001-230	1
7	Wire assy-Blk/Blu, 6 1/2"	8220-001-231	1
8	Wire Assy, GRN, 7"	8220-001-478	1
9	Screw- 10-32TTx1/2 GRN	9545-008-027	2
10	Lockwasher, External tooth	8641-582-006	2
11	Transformer, w/Circuit braker	8711-007-002	1
12	Screw, 5/16-10AB-3/8	9545-008-024	2
13	Relay-Motor, 30Amp, 24VAC	5192-299-002	1
14	Screw, 5/16-10AB-3/8	9545-008-024	2
*	Wire assy-Blk/Red, 15"	8220-146-003	2
*	Wire assy-Blk/Blu, 15"	8220-146-004	2
15	Control Assy, Ignition (Module)	9857-182-001	1
16	Screw-8Bx3/4"	9545-045-007	2
*	Harness, Ignition Module	9627-867-004	1
17	Wire Assy- High Voltage Lead	9631-403-005	1
18	Wire Assy-Red, 12"	8220-067-004	1
19	Wire Assy- White, 12"	8220-067-003	1
20	Drive-VD Inverter, 1HP, 120VAC	9375-031-003	1
PS	Key Pad, Delta E-Drive	9150-044-001	1
21	Screw-#10B x 1/2	9545-008-026	4
22	Wire Assy-Green, 18"	8220-092-006	1
*	Wire Assy-BRN, 19"	8220-078-019	1
*	Wire Assy-Yellow, 20"	8220-082-002	1
*	Wire Assy-Gray, 18"	8220-078-018	1
*	Wire Assy, Brown 3"	8220-057-035	1
23	Resistor-Dynamic Breaking, 2000HM	9483-004-002	1
24	Screw-5/16, 10ABx3/8	9545-008-024	2
25	Wire Assy, Violet 24"	8220-118-001	2
26	Relay, 120VAC	5192-285-001	1
27	Relay, 24VAC	5192-285-004	1
28	Screw, 6B x 3/8	9545-031-005	4
*	Wire Assy-BLK/BLU, 15"	8220-150-002	1
*	Wire Assy-BLK/RED, 12"	8220-150-001	1
*	Harness, Control	9627-770-001	1
29	Stand off	9527-007-001	7

Wiring Informative for 60hz Dryer - 10BD

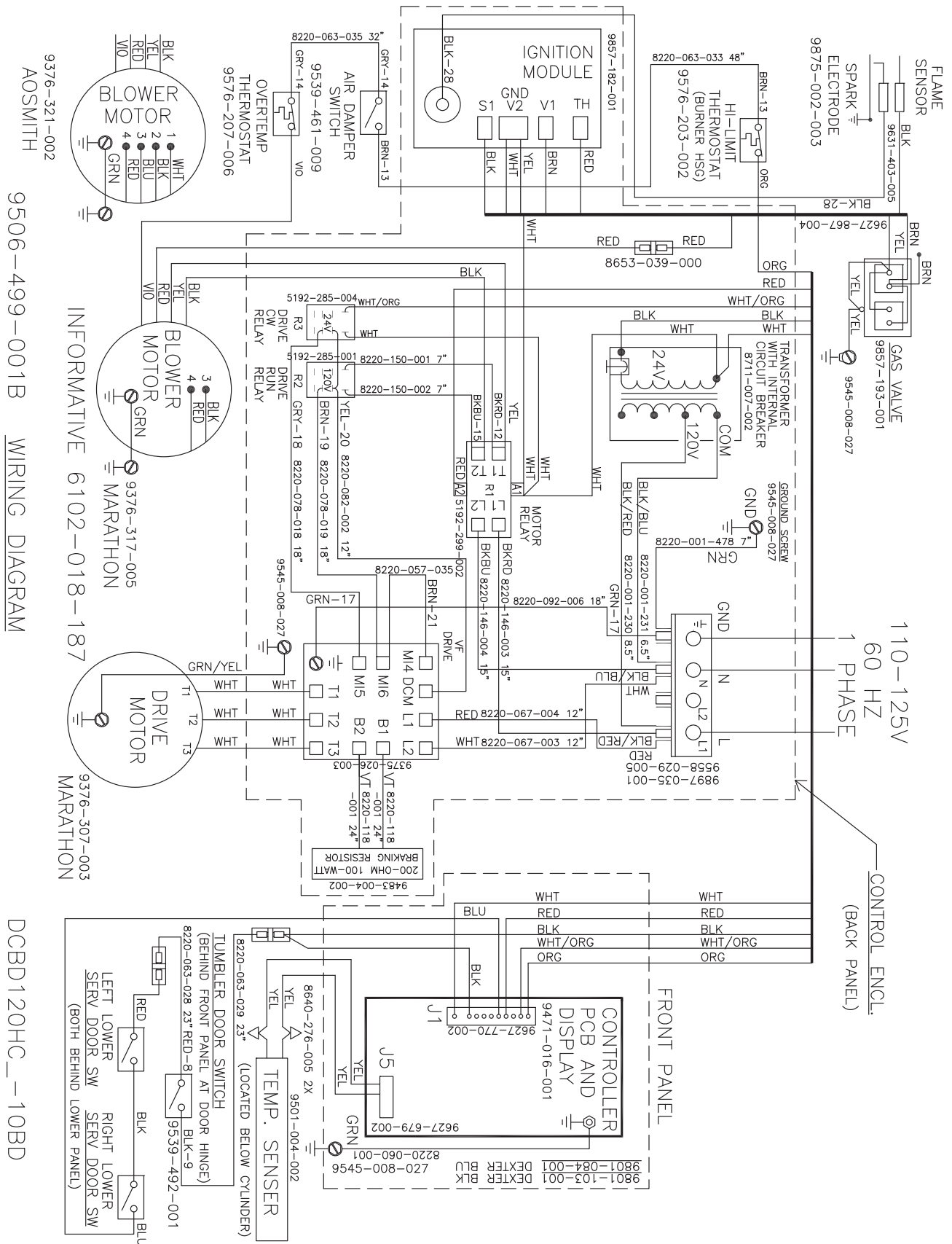

Wiring Schematic for 60hz Dryer -10BD

CAUTION: LABEL ALL WIRES PRIOR TO DISCONNECTION WHEN SERVICING CONTROLS. WIRING ERRORS CAN CAUSE IMPROPER AND DANGEROUS OPERATION. VERIFY PROPER OPERATION AFTER SERVICING.
 ATTENTION: AU MOMENT DEL'ENTRIEN DES COMMANDES, ETIQUETEZ TOUS LES FILS AVANT DE LES DEBRANCHER. DES ERREURS DE CABLAGE PEUVENT ENTRAINER UN FONCTIONNEMENT INADEQUAT ET DANGEREUX. S'ASSURER QUE L'APPAREIL FONCTIONNE ADEQUATEMENT UNE FOIS L'ENTRIEN TERMINE.

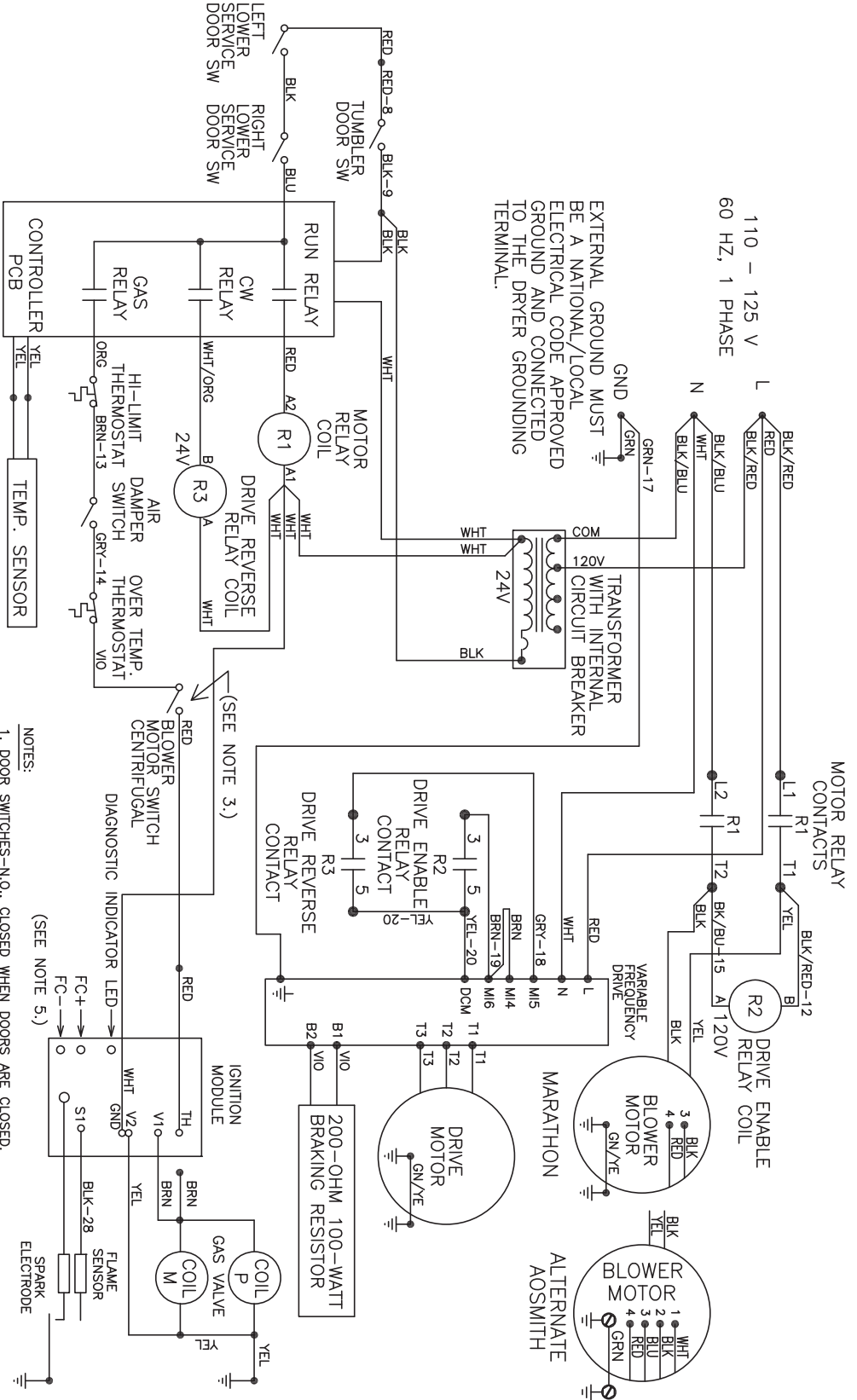

- NOTES:
1. DOOR SWITCHES-N.O., CLOSED WHEN DOORS ARE CLOSED.
 2. DRYER STARTS WHEN THE DOORS ARE CLOSED, A CYCLE IS SELECTED, AND THE START BUTTON IS PUSHED. THERE IS AN AUTOMATIC COOL DOWN AT THE END OF THE CYCLE.
 3. CENTRIFUGAL SWITCH-N.O., CLOSES WHEN MOTOR IS UP TO SPEED.
 4. REFER TO OWNER'S MANUAL FOR DESCRIPTION OF OPERATION AND REQUIREMENTS FOR HEATING CIRCUIT.
 5. WITH A DC MICROAMMETER, FLAME CURRENT CAN BE MEASURED AT TEST POINTS. READING SHOULD BE 0.7UA DC OR HIGHER.

9506-499-001C

SCHEMATIC

DCBD120HC_ -10BD

Wiring Diagram for 60hz Dryer -10BD

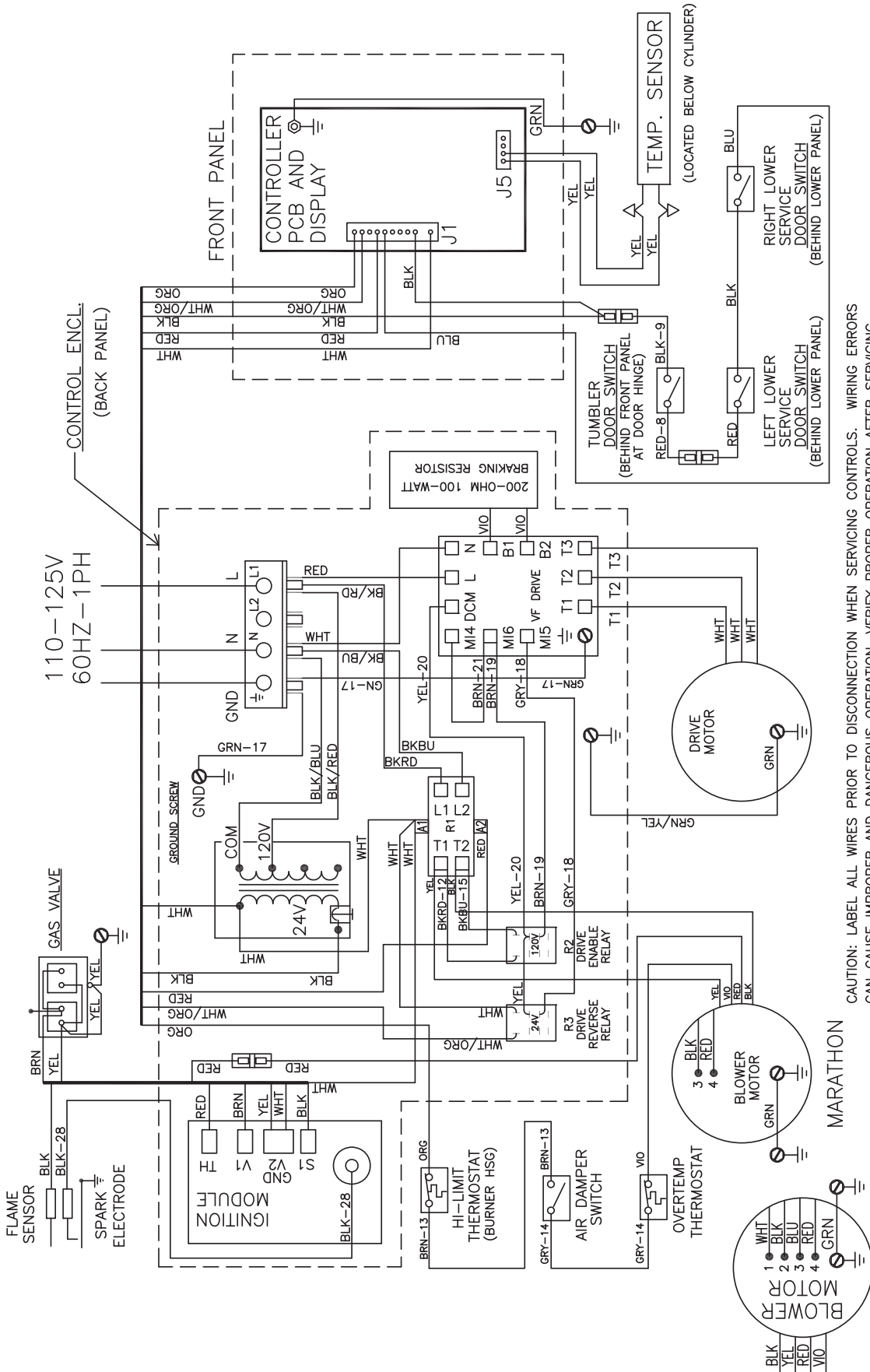

CAUTION: LABEL ALL WIRES PRIOR TO DISCONNECTION WHEN SERVICING CONTROLS. WIRING ERRORS CAN CAUSE IMPROPER AND DANGEROUS OPERATION. VERIFY PROPER OPERATION AFTER SERVICING.

ATTENTION: AU MOMENT DE L'ENTRIEN DES COMMANDES, ÉTIQUETEZ TOUS LES FILS AVANT DE LES DÉBRANCHER. DES ERREURS DE CÂBLAGE PEUVENT ENTRAÎNER UN FONCTIONNEMENT INADÉQUAT ET DANGEREUX. S'ASSURER QUE L'APPAREIL FONCTIONNE ADEQUATEMENT UNE FOIS L'ENTRETIEN TERMINÉ.

DCBD120HC_-10BD

WIRING DIAGRAM

9506-499-001C

DCBD120HC_-39BD

Section 6:

50Hz
Dryer Parts Data

Wiring Informative for 50hz Dryer -39BD

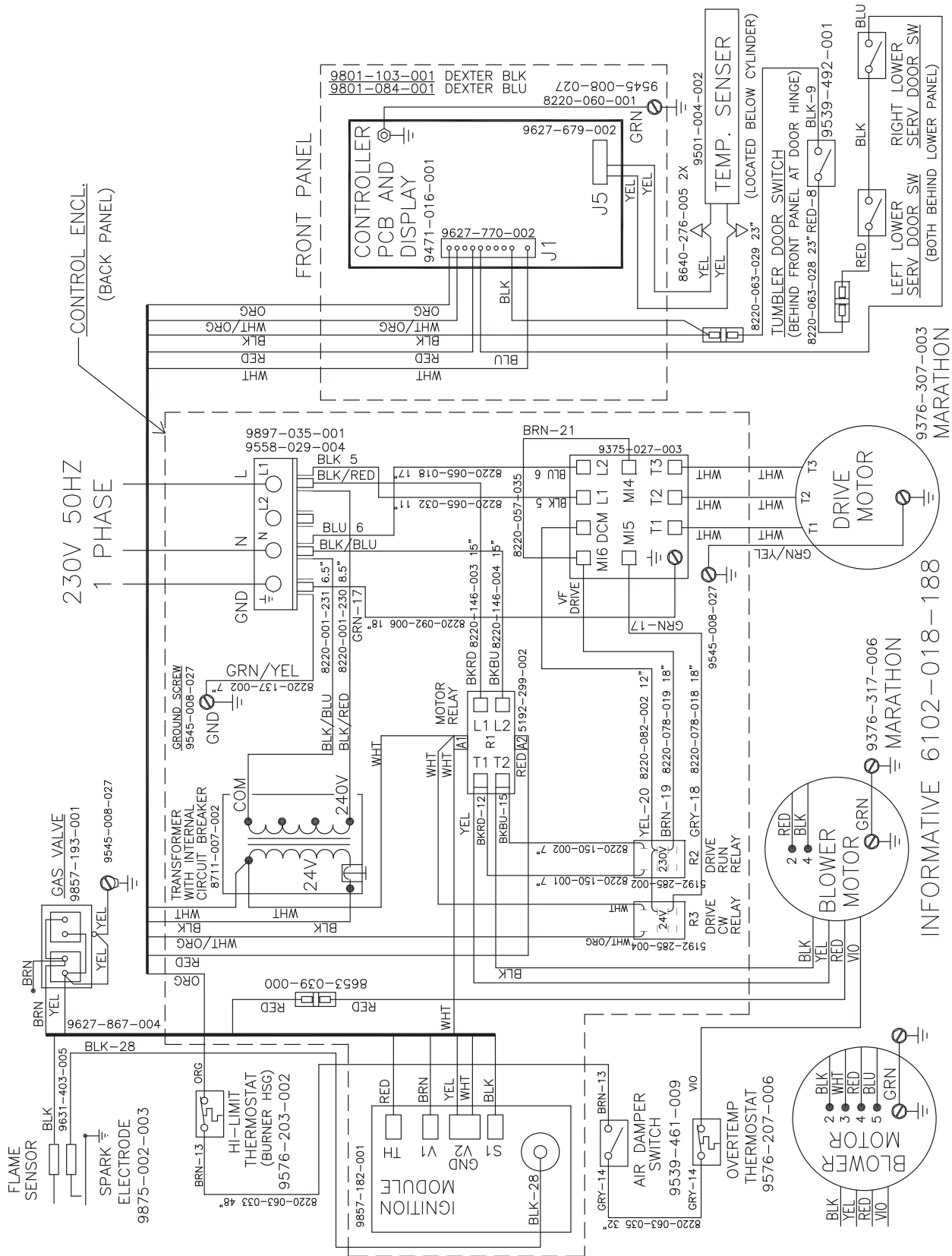

DCBD120HC_ - 39BD

9506-500-001A WIRING DIAGRAM

INFORMATIVE 6102-018-188

9376-321-002
AOSMITH

DCBD120HC_-39 230VAC 1 PH 50Hz

Key	Description	T-120	QTY
*	Control Assembly, (1 thru 28)	9857-195-002	
1	Channel-Controls	9081-163-001	1
2	Screw, 5/16-10AB-3/8	9545-008-001	6
3	Strip-Marker, Terminal	9558-029-004	1
4	Terminal Block Assy-Power, 4Pole	9897-035-001	1
5	Screw, 5/16-10AB-3/8	9545-008-024	2
6	Wire assy-Blk/Red, 6 1/2"	8220-001-230	1
7	Wire assy-Blk/Blu, 6 1/2"	8220-001-231	1
8	Wire Assy, GRN/YEL, 7"	8220-137-002	1
9	Screw- 10-32TTx1/2 GRN	9545-008-027	2
10	Lockwasher, External tooth	8641-582-006	2
11	Transformer, w/Circuit braker	8711-007-002	1
12	Screw, 5/16-10AB-3/8	9545-008-024	2
13	Relay-Motor, 30Amp, 24VAC	5192-299-002	1
14	Screw, 5/16-10AB-3/8	9545-008-024	2
*	Wire assy-Blk/Red, 9"	8220-146-003	2
*	Wire assy-Blk/Blu, 9"	8220-146-004	2
15	Control Assy, Ignition (Module)	9857-182-001	1
16	Screw-8Bx3/4"	9545-045-007	2
*	Harness, Ignition Module	9627-867-004	1
17	Wire Assy- High Voltage Lead	9631-403-005	1
18	Wire Assy-BLK, 11"	8220-065-032	1
19	Wire Assy- BLU, 11"	8220-065-018	1
20	Drive-VD Inverter, 1HP, 230VAC	9375-032-003	1
20	Key Pad, Delta E-Drive	9150-044-001	
21	Screw-#10B x 1/2	8640-413-002	4
22	Wire Assy-Green, 18"	8220-092-006	1
*	Wire Assy-BRN, 19"	8220-078-019	1
*	Wire Assy-Yellow, 20"	8220-082-002	1
*	Wire Assy-Gray, 18"	8220-078-018	1
*	Wire Assy, Brown 3"	8220-057-035	1
26	Relay, 230VAC	5192-285-002	1
27	Relay, 24VAC	5192-285-004	1
28	Screw, 6B x 3/8	9545-031-005	4
*	Wire Assy-BLK/BLU, 15"	8220-150-002	1
*	Wire Assy-BLK/RED, 12"	8220-150-001	1
*	Harness, Control	9627-770-002	1

Control Box Informatve for 50hz Dryer -39BD

INFORMATIVE 6102-018-192

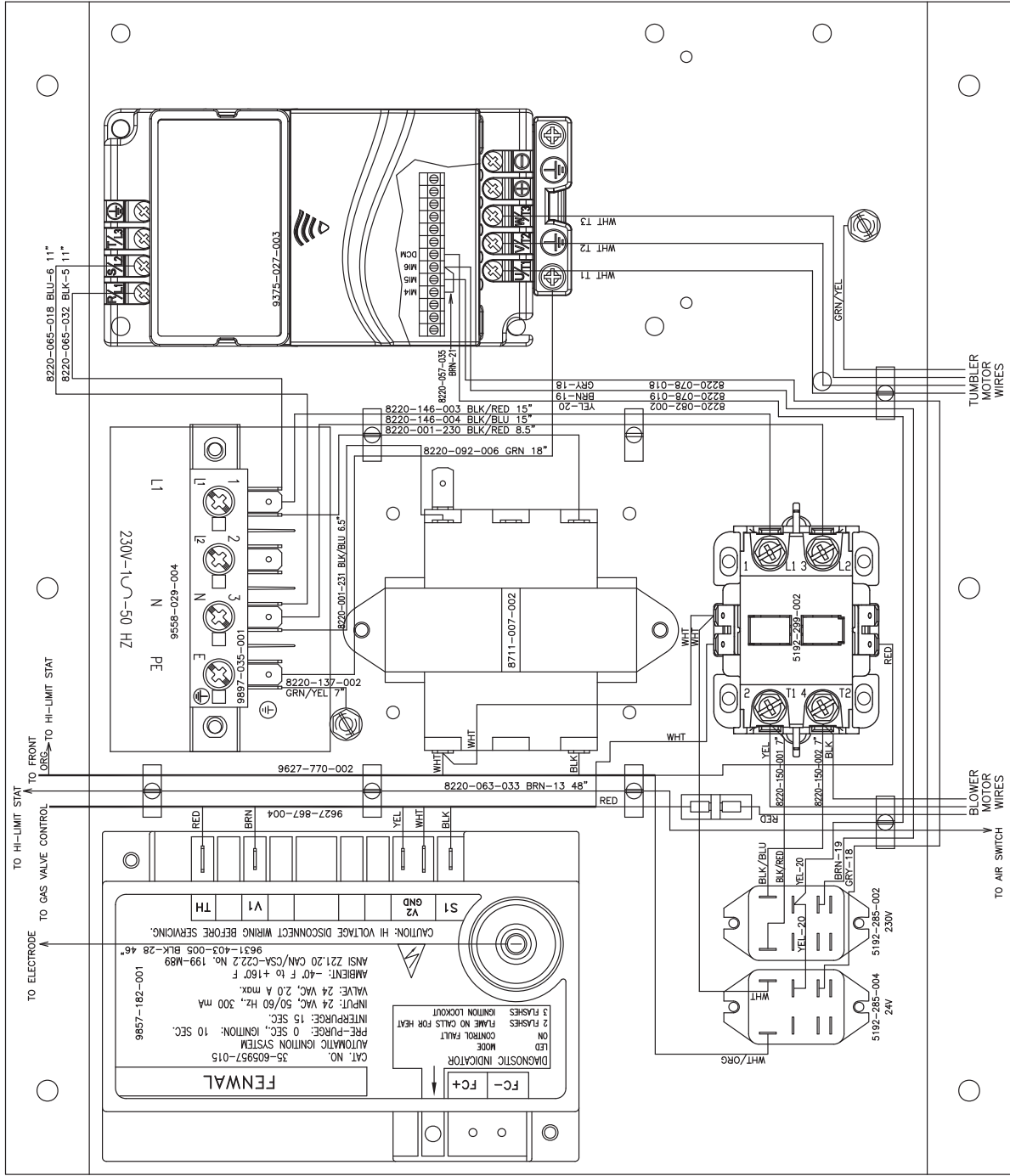

DCBD120HC_--39BD

SAMPLE BOX

9081-163-001B

Wiring Schematic for 50hz Dryer -39BD

9506-500-001B

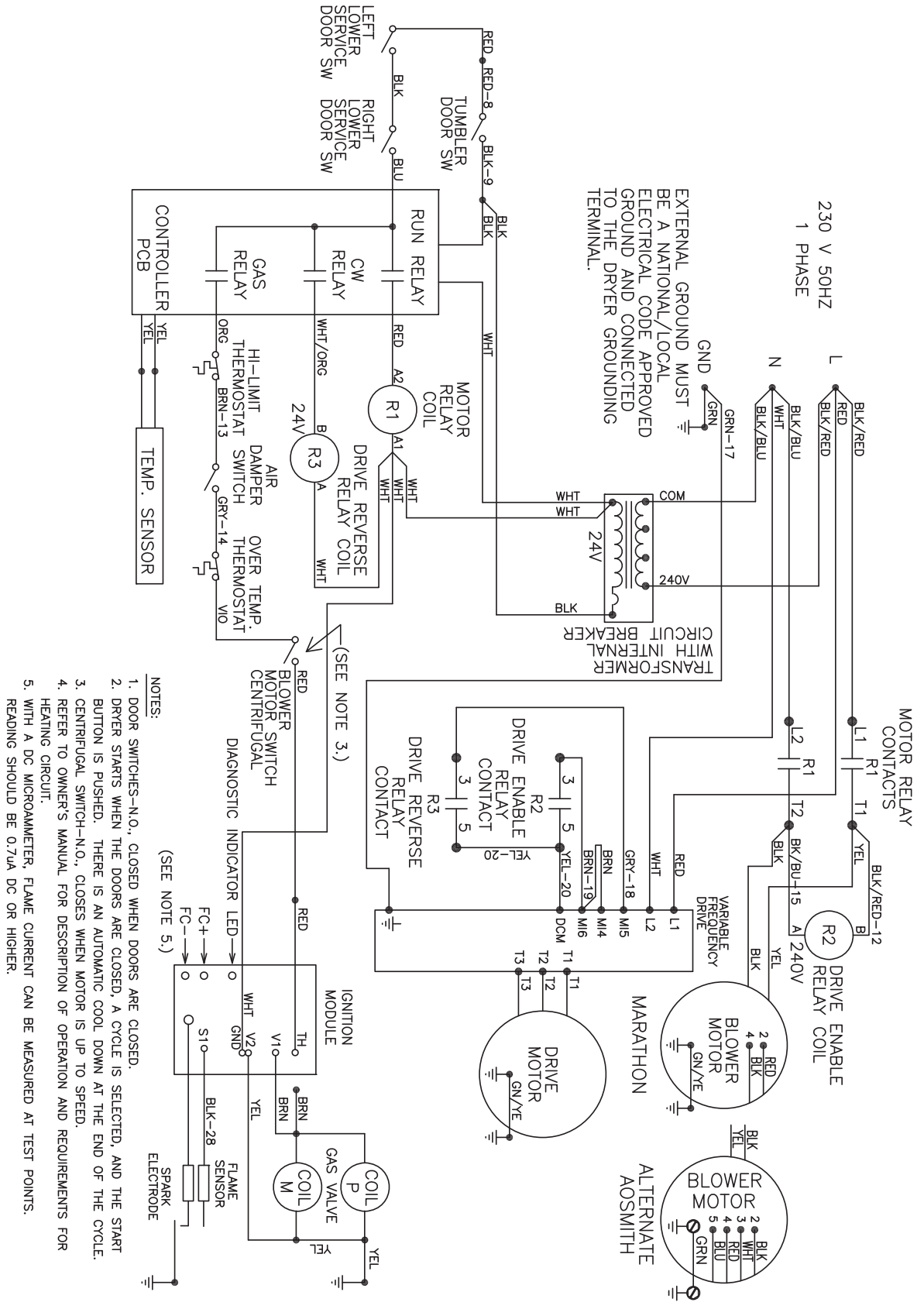

- NOTES:**
1. DOOR SWITCHES-N.O., CLOSED WHEN DOORS ARE CLOSED.
 2. DRYER STARTS WHEN THE DOORS ARE CLOSED, A CYCLE IS SELECTED, AND THE START BUTTON IS PUSHED. THERE IS AN AUTOMATIC COOL DOWN AT THE END OF THE CYCLE.
 3. CENTRIFUGAL SWITCH-N.O., CLOSES WHEN MOTOR IS UP TO SPEED.
 4. REFER TO OWNER'S MANUAL FOR DESCRIPTION OF OPERATION AND REQUIREMENTS FOR HEATING CIRCUIT.
 5. WITH A DC MICROAMMETER, FLAME CURRENT CAN BE MEASURED AT TEST POINTS. READING SHOULD BE 0.7UA DC OR HIGHER.

SCHEMATIC

DCBD120HC--39BD

Wiring Diagram for 50hz Dryer -39BD

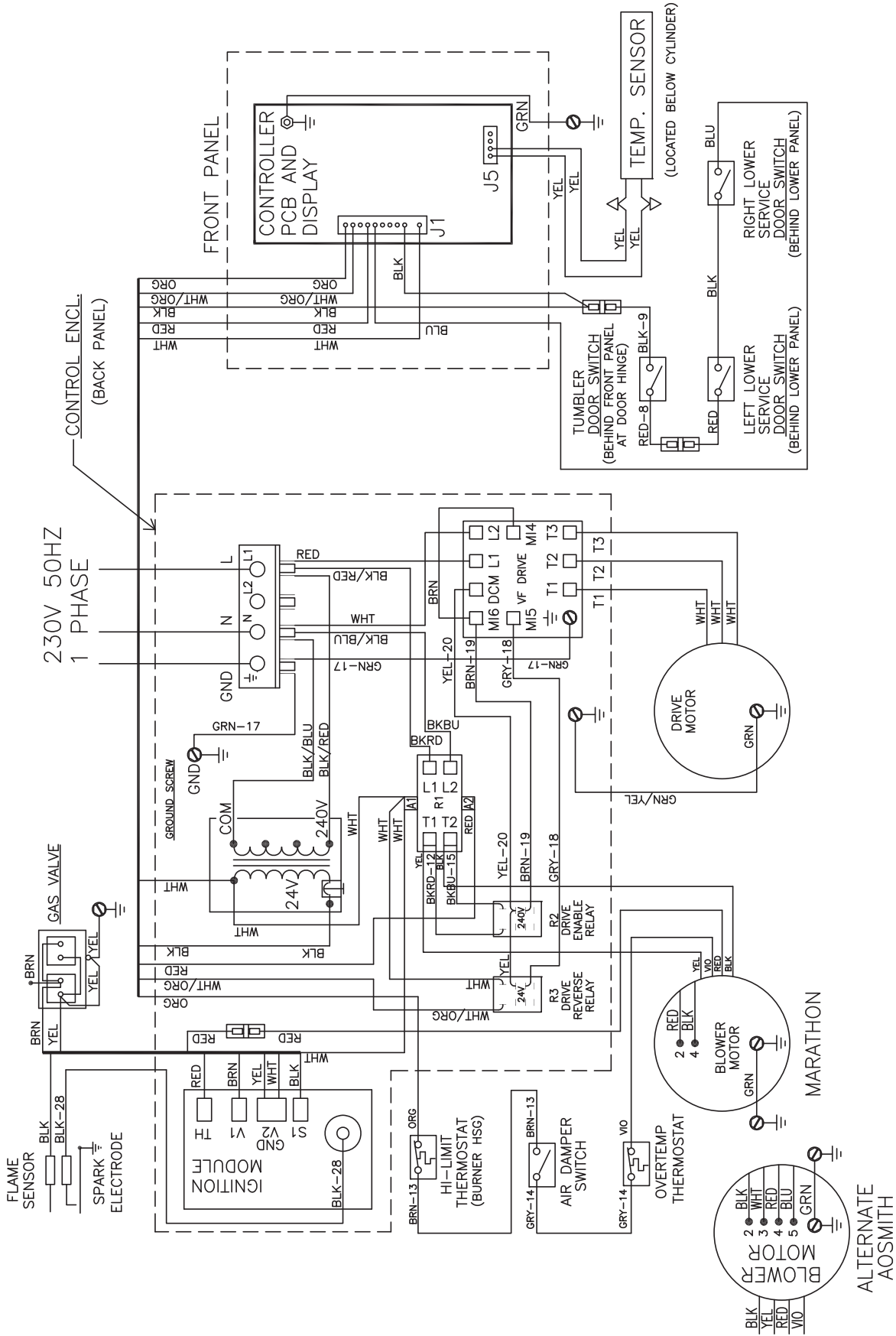

DCBD120HC_--39BD

WIRING DIAGRAM

9506-500-001B

