



Section: 7

Parts Data

DC20X2

24VAC Control

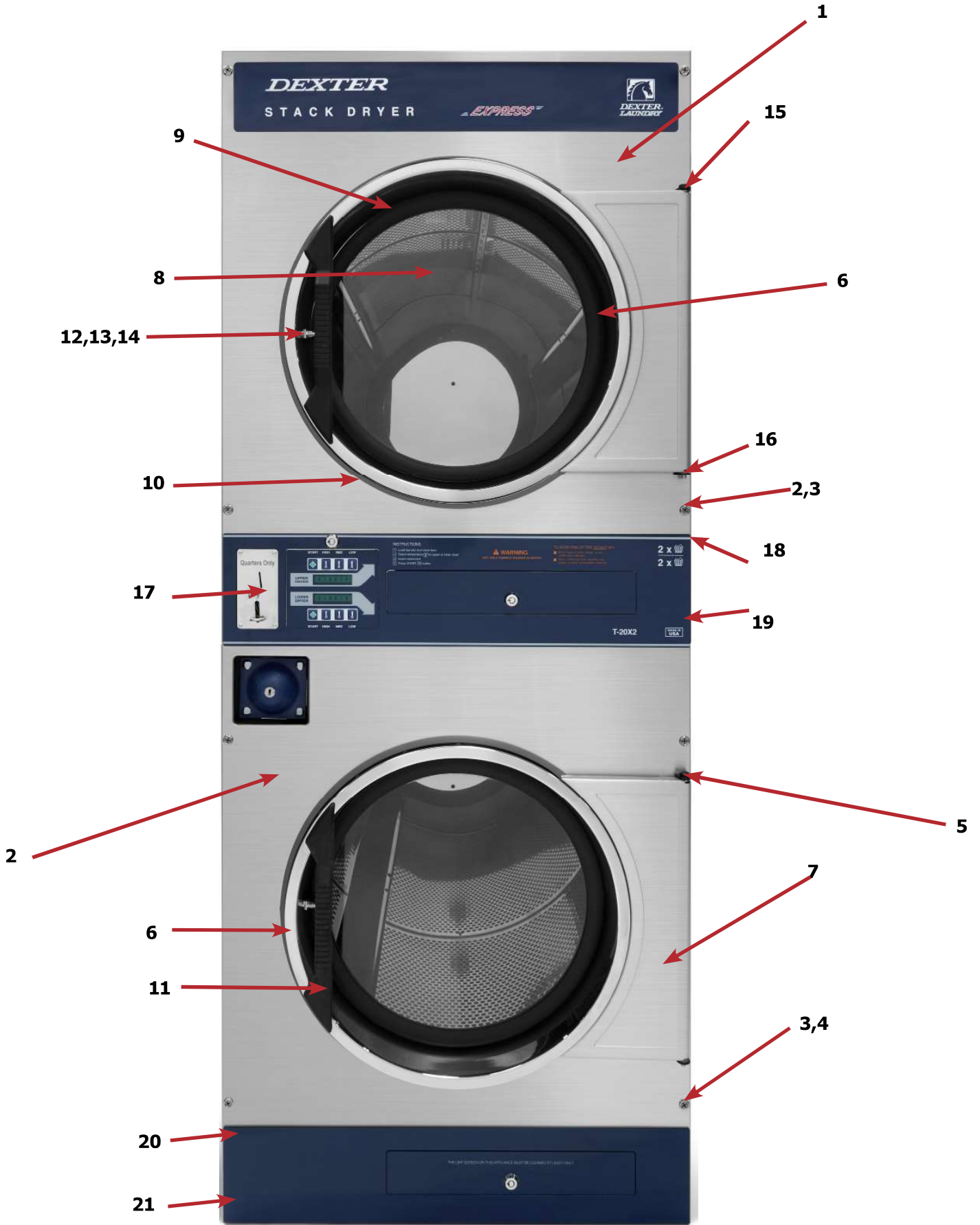

Dryer Cabinet Group

Key	Description	T-20x2	QTY
1	Panel Assy., Front- Upper (SS)	9989-610-001	1
2	Panelassy-front,coin(lower,ss	9989-611-001	1
*	Insulation Front Panel, half moon (top)	9277-064-001	2
*	Insulation Front Panel, half moon (bottom)	9277-064-002	2
3	Screw, FLHDCR, 10B x 1 3/4	9545-008-014	8
4	Washer, Finish, #10	8641-585-001	8
*	Nut, Spring	8640-399-001	8
*	Hinge ,Backup Plate	9982-392-001	2
*	Screw, Countersink, 10-32X 1/2	9545-012-003	4
5	Strap, Hinge (SS/Black)	9544-074-002	2
*	Screw, Hinge to Panel	9545-012-028	8
6	Door Assy., Loading Complete-Chrome/BLK/SS	9960-315-002	2
*	Door Assy., Loading-Chrome (Ring Only)	9960-314-003	2
6	Door Assy., Loading Complete-SS/BLK/SS	9960-315-001	2
*	Door Assy., Loading-SS (Ring Only)	9960-314-001	2
7	Plate Assy., Hinge (SS)	9982-393-001	2
*	Screw, Hinge to Door	9545-012-015	8
*	Nut, Hinge to Door	8640-413-002	8
*	Cover, Hinge Plate	9074-377-002	2
*	Screw, Phillips-10B x 3/8	9545-008-010	4
8	Glass, Door	9212-002-005	2
9	Gasket, Glass Black	9206-413-003	2
*	Support, Door Glass	9548-117-000	4
*	Tool Install Dryer Door Gasket	8545-064-001	1
10	Gasket, Outer Rim Black	9206-420-006	2
11	Handle, Loading Door	9244-092-001	2
*	Screw, Handle 1/4-20 x 3/8	9545-018-017	4
12	Stud, Door Catch, 7/8	9531-033-002	2
13	Nut, Hex	8640-413-001	2
14	Nut, Acorn	8640-413-003	2
*	Catch, Loading Door	9086-015-002	2
*	Pop Rivet for mtg. catch	8638-190-009	4
15	Screw, Door to Hinge Strap (Special Black Type)	9545-052-001	2
16	Washer, Fiber	8641-436-003	2
17	Acceptor, Coin	9021-092-002	1
*	Retainer, Coin Acceptor	9486-149-001	2
*	Screw, 4Bx5/8ss, T10	9545-053-002	4
*	Switch, Optical	9801-099-001	1
18	Escutcheonassy-dry,coin,upr	9994-043-001	1
19	Overlay-esc,t-20x2,up,coin,blu	9435-058-002	1
*	Overlay-esc,t-20x2,up,coin,black	9435-058-001	1
*	Screw, #4-40 x 3/16	9545-020-009	23
20	Escutcheonasy-dry,coin/opl,lwr	9994-045-001	1
21	Overlay-escut,t-20x2,lwr,blue	9435-060-002	1
*	Overlay-escut,t-20x2,lwr,black	9435-060-001	1

Cabinet Group Continued

Key	Description	T20X2	QTY
22	Nameplate Stack Dryer Express Blue	9412-251-002	1
22	Nameplate Stack Dryer Express Black	9412-251-001	1
23	Lint Drawer Assembly Blue	9866-008-001	1
23	Lint Drawer Assembly Black	9866-008-003	1
*	Drawer, Front	9974-016-002	1
*	Washer, Flat, #10	8641-581-006	2
*	Washer, Curved-Spring	8641-569-004	2
*	Nut, 10-32	8640-413-007	2
24	Overlay Trim, Lint Drwr-Blue	9435-053-002	1
24	Overlay Trim, Lint Drwr-Black	9435-053-001	1
*	Felt Seal (back of lint screen assembly)	9532-074-004	1
*	Lint Screen Assembly ONLY (no front)	9805-036-002	1
*	Replaceable Lint Screen Only	9555-057-011	1
25	Lock and Key, Lint Drawer	8650-012-004	1
*	Key 6101 only	6292-006-010	1
*	Cam, Lock	9095-043-001	1
*	Lint Screen Strap Hold Down Screws 10Bx 1/4	9545-008-001	12
26	Controls Assy, 24VAC, Blue	9857-198-002	1
26	Controls Assy, 24VAC, Black	9857-198-004	1
*	Wireharness-main,dry,t-20x2	9627-911-006	1
27	Lock and Key, Control	8650-012-003	1
*	Cam, Lock	9095-041-001	1
*	Washer-flat,shim	8641-581-010	2
*	Washer-flat	8641-581-041	1
*	Key only 6324	6292-006-007	1
28	Sensor Temp Control	9501-006-001	2
*	Wiringharness-heatsensor	9627-855-003	1
*	Wire Nut Connector Grey	8640-276-002	4
29	Bracket-mtg,lintdrawerswitch	9029-297-001	2
30	Switch-door,lowerservice	9539-487-001	2
	Grommet-wire, 1/2 I.d"	9209-089-001	2
	Plug-plastic,5/8"	9456-041-010	2
	Screw-hxwshrhdundct,#10bx1/2	9545-008-026	4
31	Cover, Cabinet (Top)	9074-374-001	1
*	Insulation Cabinet Cover	9277-041-028	1
*	Insulation-side Panel	9277-041-027	2
*	Stack Dryer Trunion Puller	8545-060-002	1
32	Vault, Coin Box	9942-038-005	1
*	Plateasy-coinvaultmounting	9982-338-001	1
*	Screws, Mounting-Coin Vault	9545-008-024	2
33	Coin Box Assy, Large Blue	9807-099-002	1
33	Coin Box Assy, Large Black	9807-099-004	1

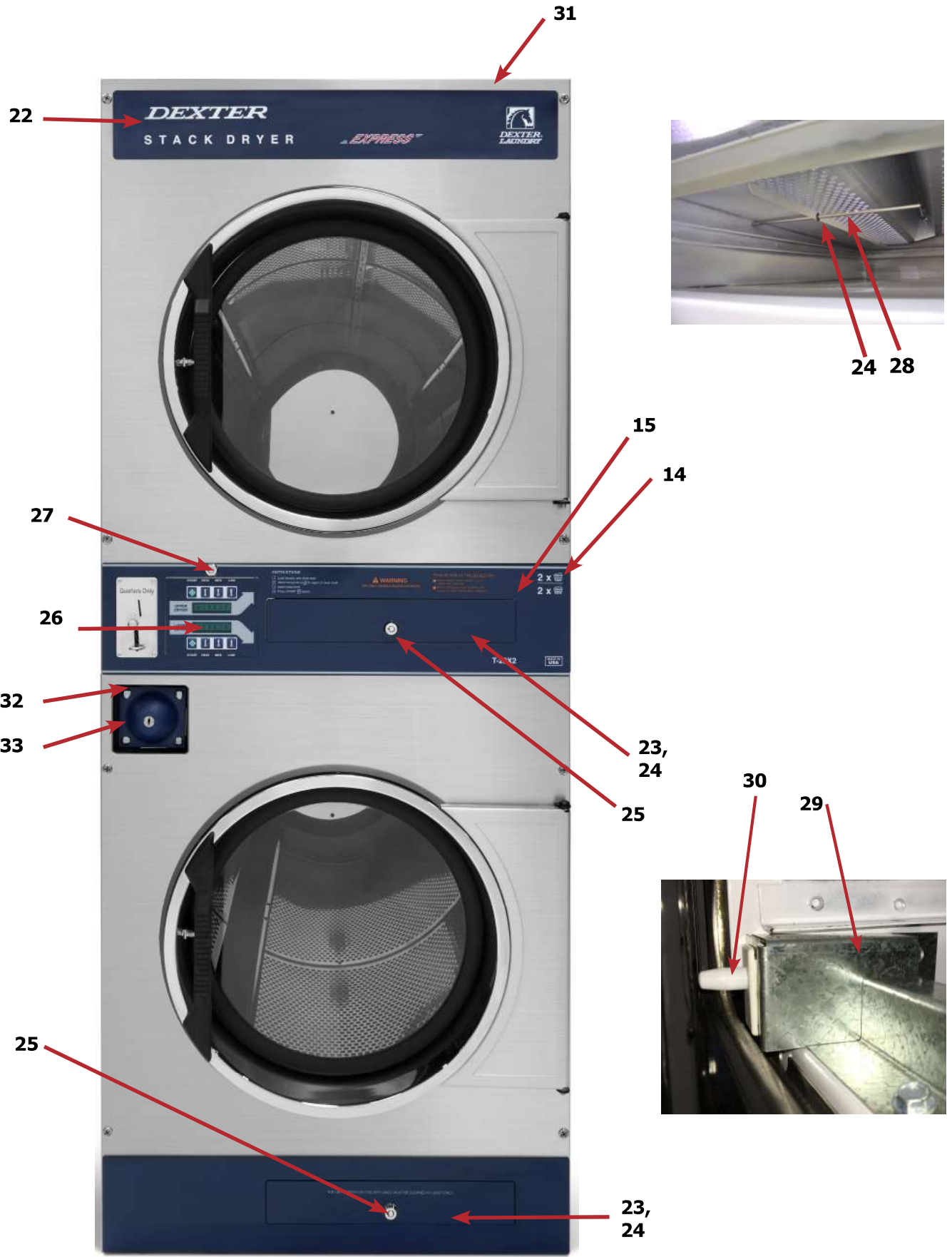

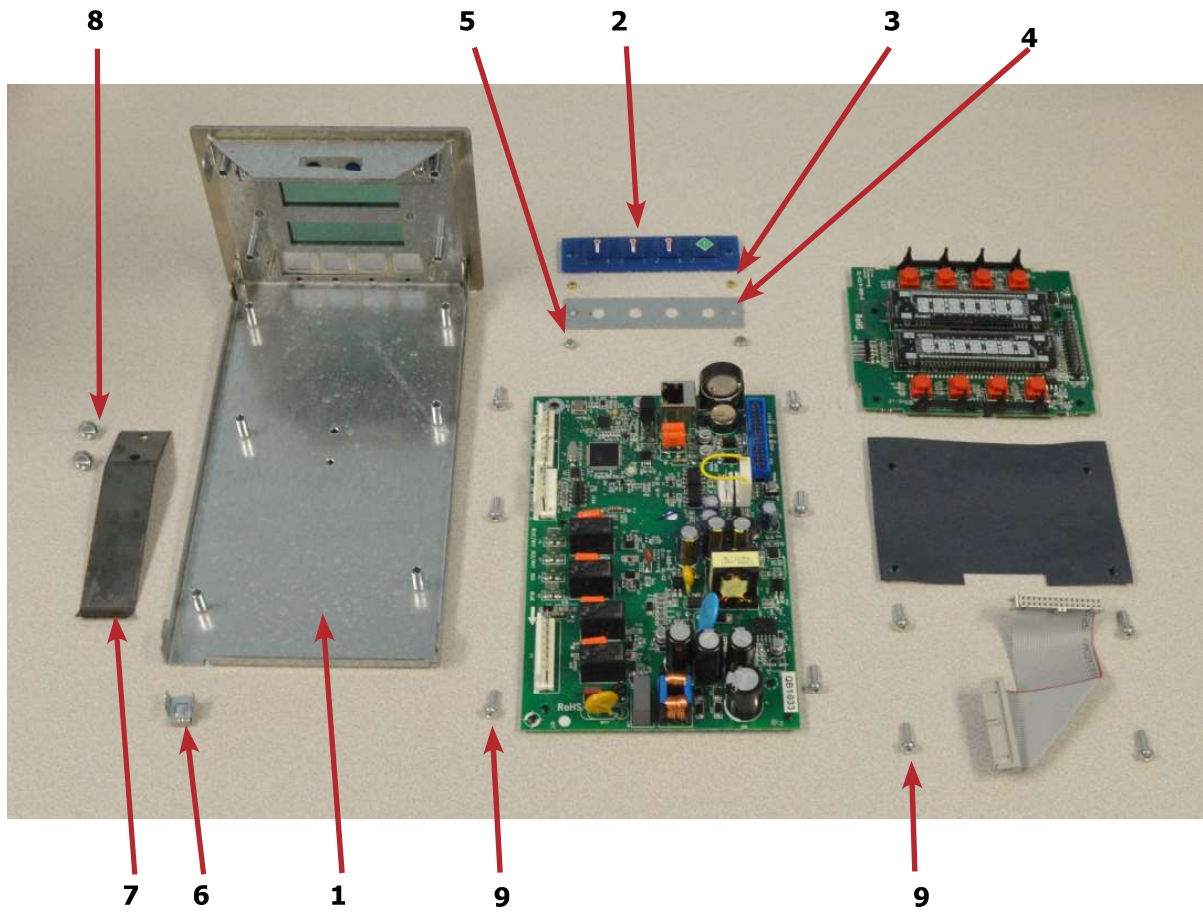

Key	Description	Part Number	Qty
*	Controls Assy, 24V, BLU	9857-198-002	1
*	Controls Assy, 24V, BLK	9857-198-004	1
1	Trough Assembly	9826-008-001	1
2	Button-Push, Control, Black	9035-062-002	2
2	Button-Push, Control, Blue...	9035-062-001	2
3	Spacer-Metal, 4mm	9538-166-011	4
4	Retainer-Push Button	9486-158-001	2
5	Nut-Hex, Elastic stop, #4-40	8640-424-002	4
6	Terminal-Grounding clip	8652-130-038	1
7	Spring-Flat, Control	9534-365-001	1
8	Screw-Hex, #10B x 1/4	9545-008-001	2
9	Screw-panhead 6-32 uncx 1/2	9545-044-010	10
9	Washer-External tooth, #6	8641-582-005	10
10	Overlay-Control, Coin, Black	9435-038-001	1
10	Overlay-Control, Coin, Blue	9435-038-002	1
11	Acceptor-Coin, Optical	9021-092-002	1
*	Retainer, Coin Acceptor	9486-149-001	1
12	Screw	9545-053-002	4
*	Optical Sensor, Replacement	9801-099-001	1
*	Wire Assy, Jumper, 30Lb Stack Coin	8220-155-001	1
*	Wire Assy, Jumper, 50Lb Stack Coin	8220-155-002	1
*	Wire Assy, Jumper, 20Lb Stack Coin	8220-155-009	1

Door Switch Group

Key	Description	T-20x2	QTY
1	Door Switches	9539-487-001	2
2	Bracket-Mounting lint tray switch	9029-297-001	2
3	Grommet Wire 1/2 i.d.	9029-089-001	2

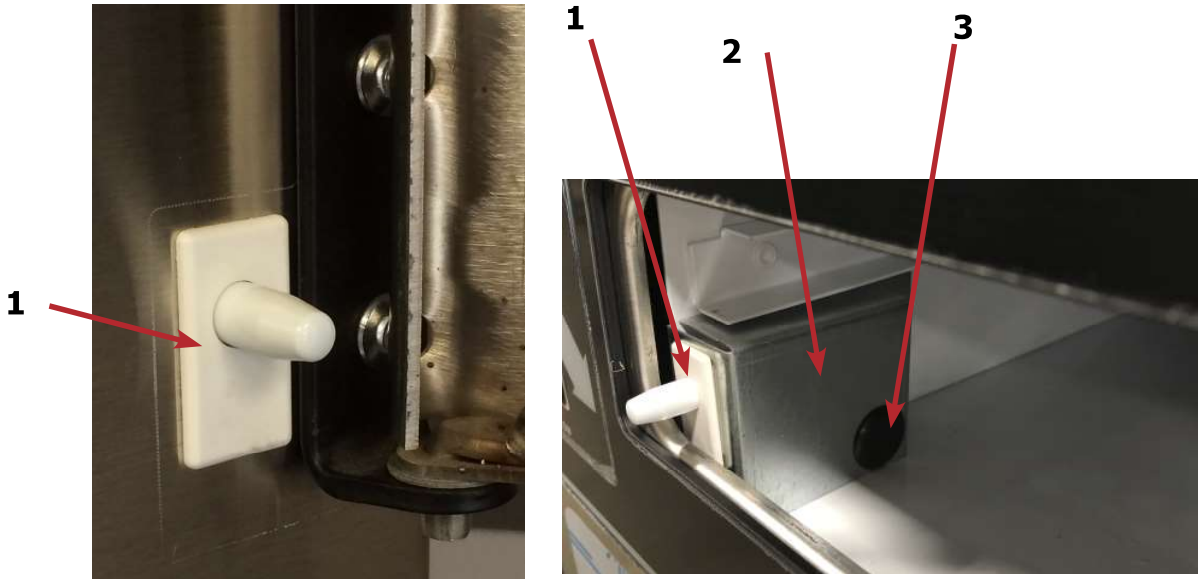

Hinge Plate Cover

Key	Description	T-20x2	QTY
1	Cover-Hinge, Black	9074-377-002	1
2	Screw-TRHDCR, 10B x 3/8, Black	9545-008-010	2

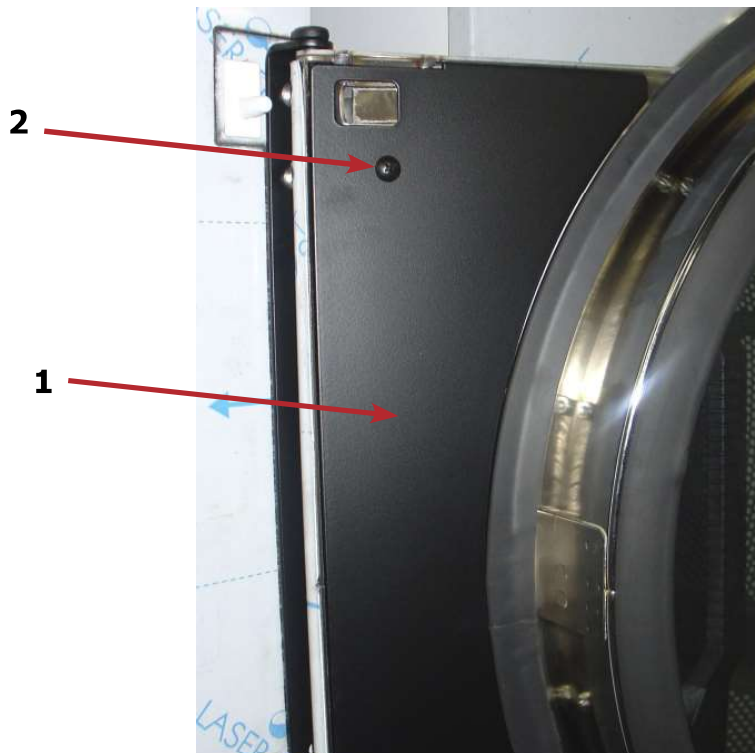

Bearing Housing Group

Key	Description	T-20x2	QTY
	Bearing Housing Complete Assy (Includes bearings & Spacer)	9803-160-003	2
1	Housing, Bearing	9241-161-002	2
*	Spacer, Bearing	9538-139-002	2
2	Bearing, Ball, Front & Rear	9036-130-001	4
3	Screw-Wizlock, 3/8-24x3/4	9545-049-002	8
4	Nut, 5/16-18	8640-400-002	8
5	Screw, 3/8-24x1	9545-049-001	4
6	Nut, 3/8-24	8640-415-002	4

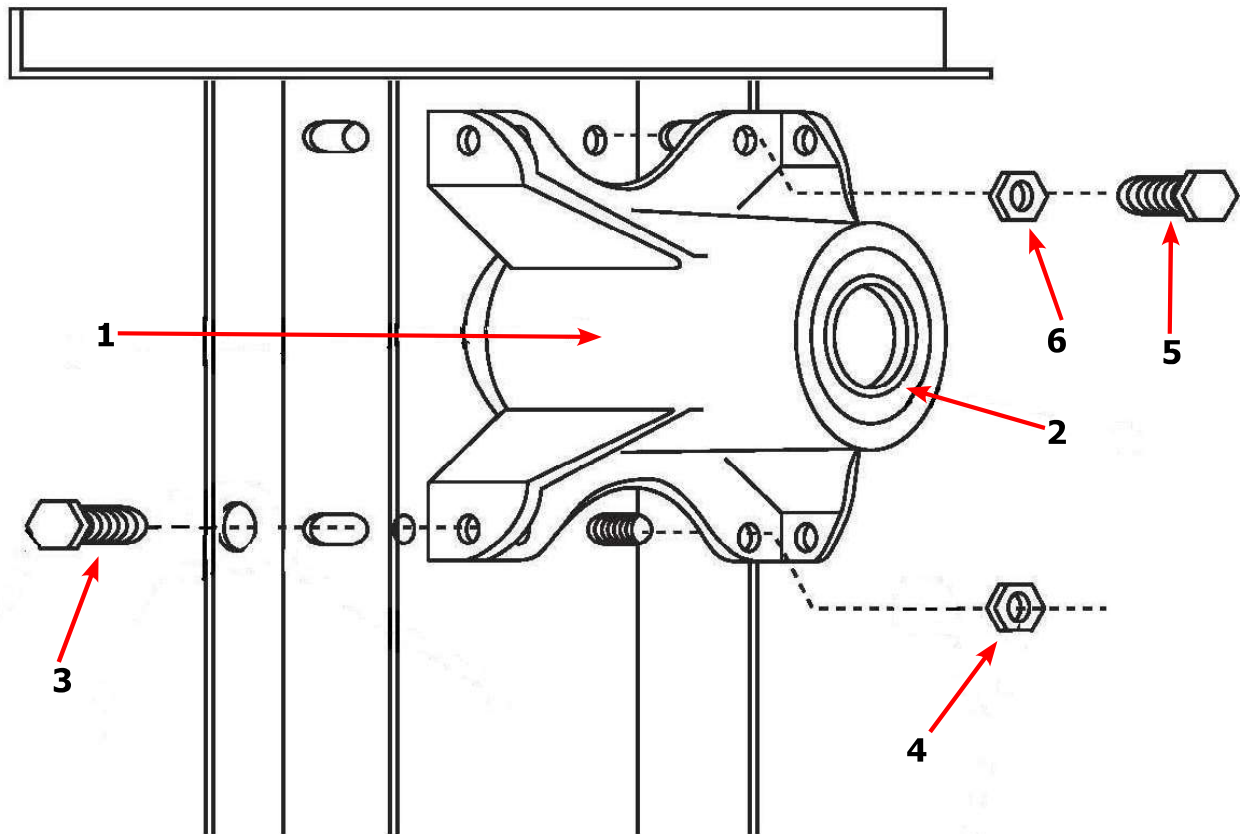

Tumbler Group

Key	Description	T-20x2	QTY
*	Tumbler Assy Complete W/Spider (GALV)	9848-156-001	2
1	Tumbler Assy (Galvanized)	9848-155-001	2
*	Tumbler Assy Complete W/Spider (SS & Galv front)	9848-156-002	2
1	Tumbler Assy (Stainless Galvanized front)	9848-155-002	2
2	Rod, Tumbler	9497-019-004	6
3	Washer, Special	8641-554-001	6
4	Shim	9552-013-000	AR
5	Spider Assy	9568-018-001	2
6	Nut, Wiz Lock	8640-415-004	6
7	Spacer-Shaft	9538-164-001	2
8	Tolerance Ring	9487-234-005	2
9	Pulley, Driven	9908-052-002	2
10	Washer -Flat 1/2	8641-581-026	2
11	LockWasher - IntTooth, 1/2"	8641-582-016	2
12	Screw, 1/2-13x1 1/4	9545-017-009	2
*	Belt, Drive	9040-073-013	2

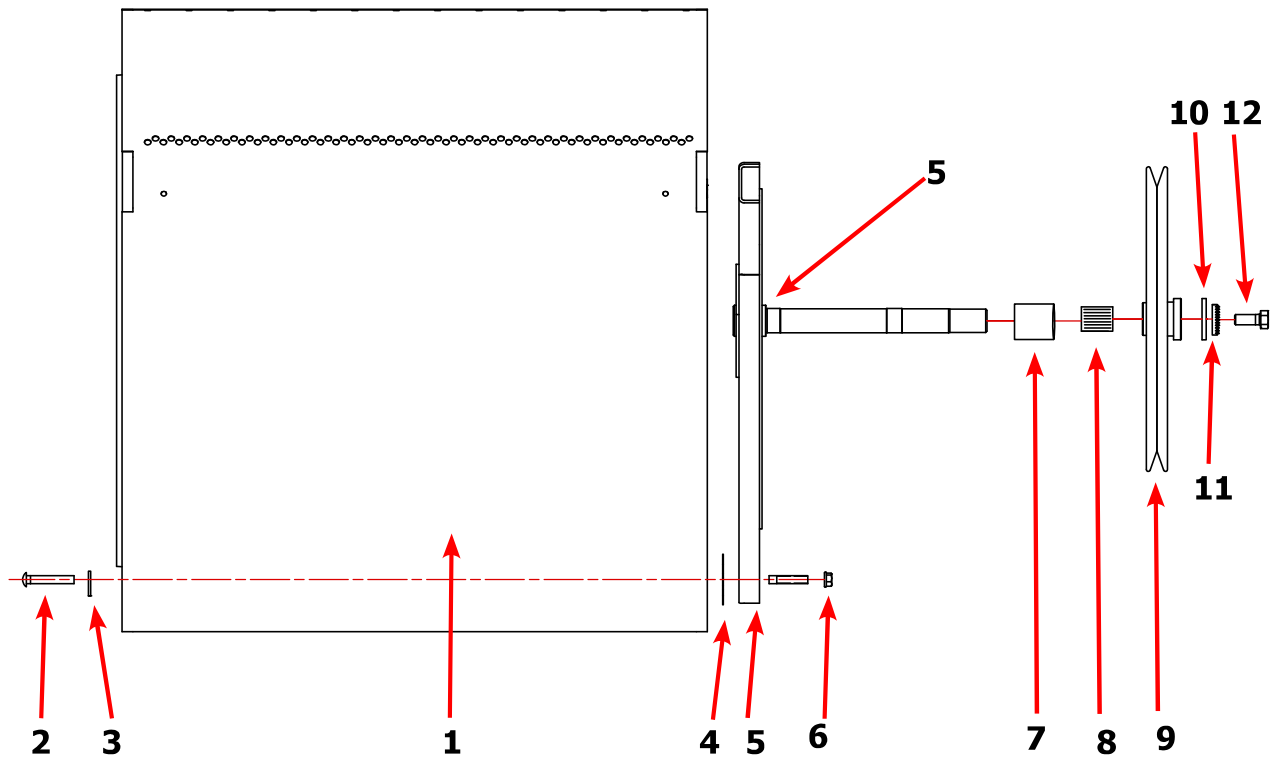

Dryer Burner Housing Group

Key	Description	T-20X2	QTY
*	Housing Assembly, Burner (All sheet metal parts not listed) Upper	9803-221-001	1
*	Cover Burner upper	9074-373-001	1
*	HOUSING ASSEMBLY - BURNER, LOWER	9803-221-002	1
1	Panel, Back Burner Housing	9454-949-001	2
2	Screw, 10B X 1/4"	9545-008-001	8
3	Angle, Burner Support	9003-220-001	2
*	Screw, 10B x 3/8"	9545-008-006	4
4	Burner, Main	9048-023-001	4
*	Screw 10AB x 3/8"	9545-008-006	4
5	Electrode-ignition	9875-002-003	2
6	Screw, Electrode Mtg 8B x 1/4"	9545-045-001	4
7	Pipeassembly-gas,t-20x2	9838-018-004	2
8	Control Assy, Gas	9857-134-001	2
9	Wireasy-yel,47/8"	8220-001-466	2
10	Manifold, Assy	9381-012-001	2
*	Orifice, Burner-Natural #40	9425-069-030	4
*	Orifice, Burner-LP #54	9425-069-031	2
11	Bracket, Manifold	9029-305-001	2
12	Pipe Plug in end of Burner Manifold	8615-104-045	2
*	Screw, 10AB x 3/8"	9545-008-006	4
13	Bracket, High Limit Thermostat	9029-192-001	2
14	Thermostat, Hi-Limit	9576-203-002	2
*	Spacer, Hi-Limit	9538-142-001	4
*	Screw 8B x 3/4"	9545-045-007	4
15	Cover, Hi-Limit Stat	9074-329-001	2
*	Screw, 10AB x 3/8"	9545-008-006	4
16	Thermostat, Safety Shutoff	9576-207-006	2
17	Screw, 10AB x 3/8"	9545-008-006	4
*	Control, Ignition Fenwall (3 trybox)	9857-182-001	2
*	Kit, LP Conversion 20Lb Stack Kit	9732-102-034	2

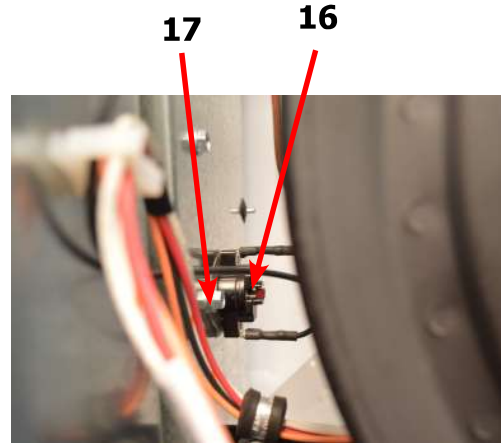
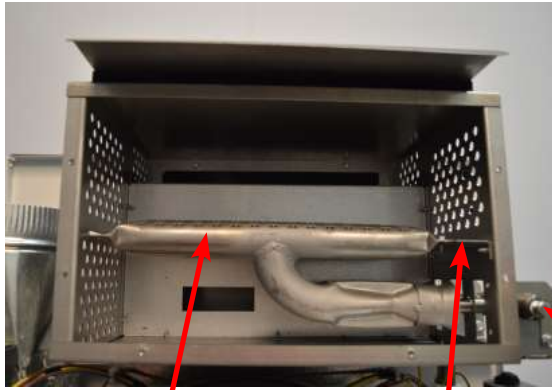
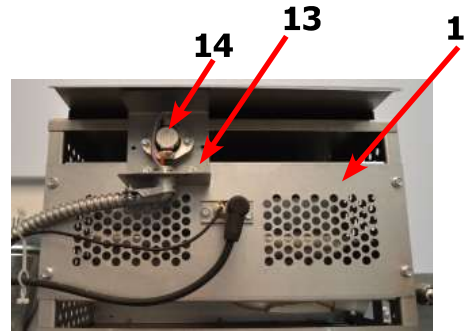
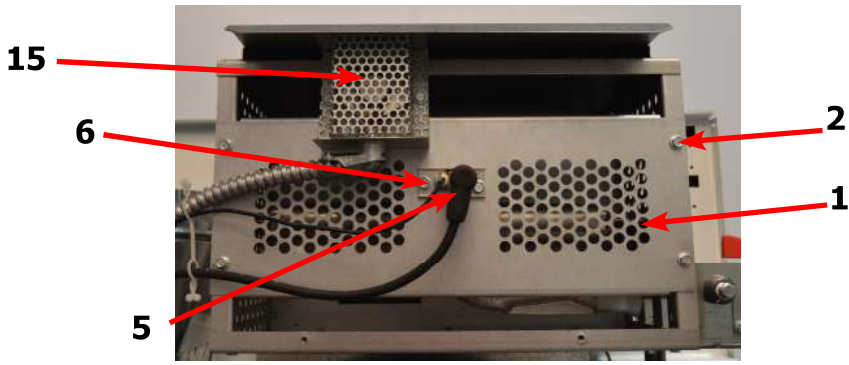

12

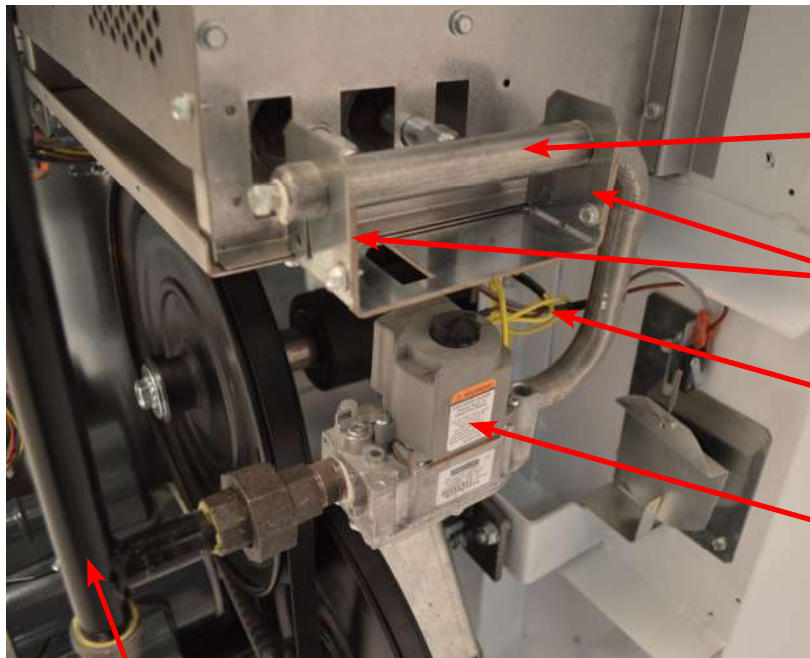

Key	Description	T-20x2	QTY
*	Switch Assy, Air Flow	9801-095-001	2
1	Switch, Air Flow	9539-461-009	2
2	Bracket, Switch- Air Flow	9029-174-001	2
3	Actuator, Switch	9008-007-001	2
4	Pin, Cotter	9451-169-002	2
5	Screw 4-40 x 5/8"	9545-020-001	4
*	Nut, Special Twin .#4-40	8640-401-001	2
*	Shield, Switch	9550-169-003	2
*	Screw 10 Bx 1/4"	9545-008-001	3
6	Motor, Drive	9376-332-001	2
*	Pulley-motor,60hz	9453-185-001	2
*	Screw-set,5/16-18x1/2	9545-028-013	2
7	Plate, Motor Mtg	9982-390-002	2
8	Screw, Motor to Plate Screw-hxflgwhzlk,5/16-18x5/8	9545-014-004	8
*	Nut-hextwinwhzlk,5/16-18	8640-400-003	8
9	Nut 1/4x20 Motor Plate to Cabinet	8640-414-007	14
10	Clamp-cable,3/4	8654-125-004	4
*	Screw-hxhdsldtmach,12abx1/2	9545-048-001	4
11	SupportAssy, Intermed. Pulley	9991-053-002	2
12	Bolt, Rd Hd 3/8-16 x 1 1/4	9545-029-010	6
13	Bolt, 3/8-16 x 1 1/2	9545-029-012	2
12	Nut Flange Wizioc 3/8" - 16	8640-415-004	6
*	Washer, Flat	8641-581-035	2
14	Arm Assy-Tension, Complete	9861-022-001	2
*	Washer, Flat	8641-581-035	4

Rear View Photos

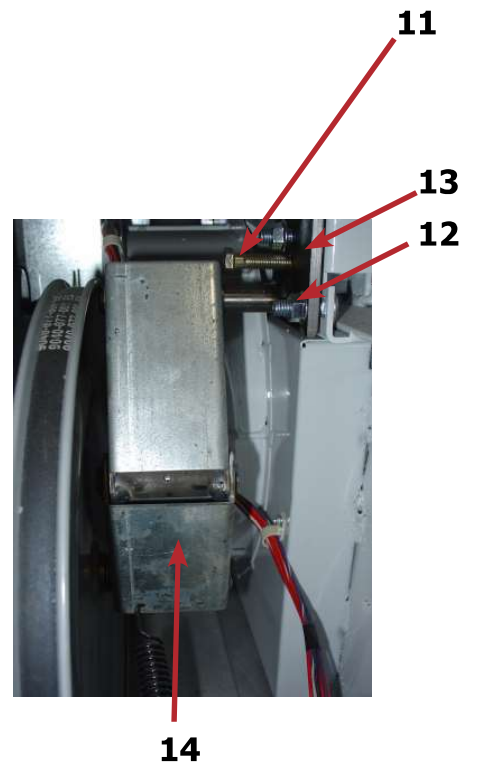
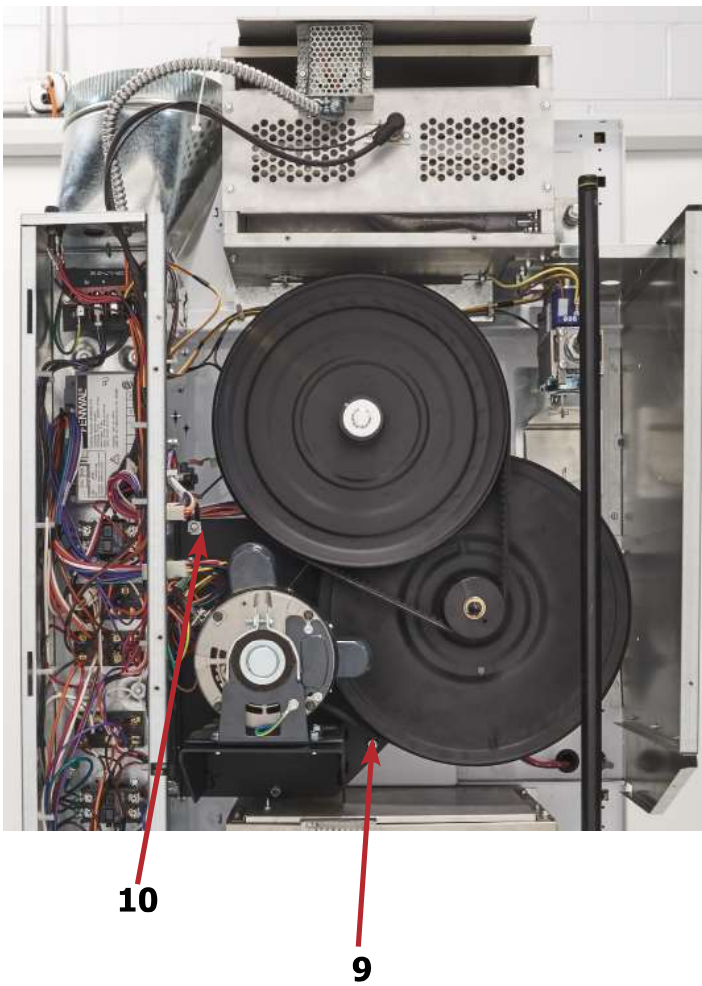
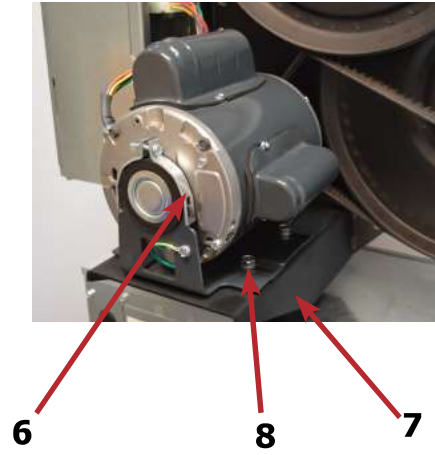
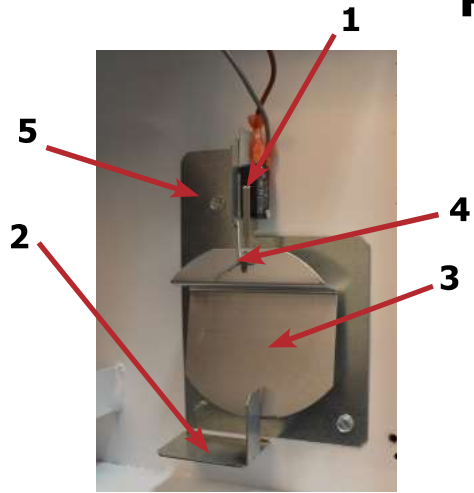

Key	Description	T-20x2	QTY
14	Arm Assy-Tension, Complete	9861-022-001	2
*	Washer, Flat	8641-581-035	6
15	Ring-Retaining	9487-200-003	6
16	Pulley Assy, Intermediate with bronze flange bearing	9908-053-003	2
*	Bearing - Bronze Flange	9036-145-002	2
*	Spacer-Shaft (See Tumbler Group for Expanded View)	9538-164-001	2
*	Tolerance Ring	9487-234-005	2
17	Pulley, Driven	9908-052-002	2
18	Washer -Flat	8641-581-026	2
18	LockWasher - IntTooth, 1/2"	8641-582-016	2
18	Screw, 1/2-13x1 1/4	9545-017-009	2
19	Belt, Drive- Motor	9040-076-012	2
20	Belt, Drive- Tumbler	9040-073-013	2
21	Spring, Tension	9534-319-002	2
22	Chain, Tension	9099-012-011	2
23	Hook, Tension	9248-022-002	2
*	Damper Inside Duct Exhaust	9125-009-001	2
24	Pin, Damper Hinge	9451-146-007	2
*	Box-duct.lower	9041-113-001	1
*	Nut, Spring	8520-141-000	4
*	Screw #10B x 1/2	9545-008-026	4
*	Cover Duct Upper	9074-382-001	1
*	Base Duct	9047-121-001	1
*	Screw 10ABx 3/8"	9545-008-024	40
26	Impeller, W/Set Screws	9278-045-001	2
27	Pulley, Motor	9453-185-001	2
28	Bracket for Wire Harness Under Burner Housing	9029-291-001	2

Rear View Photos

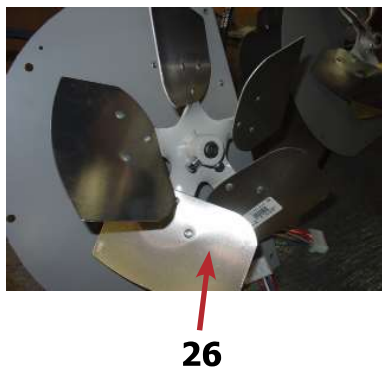
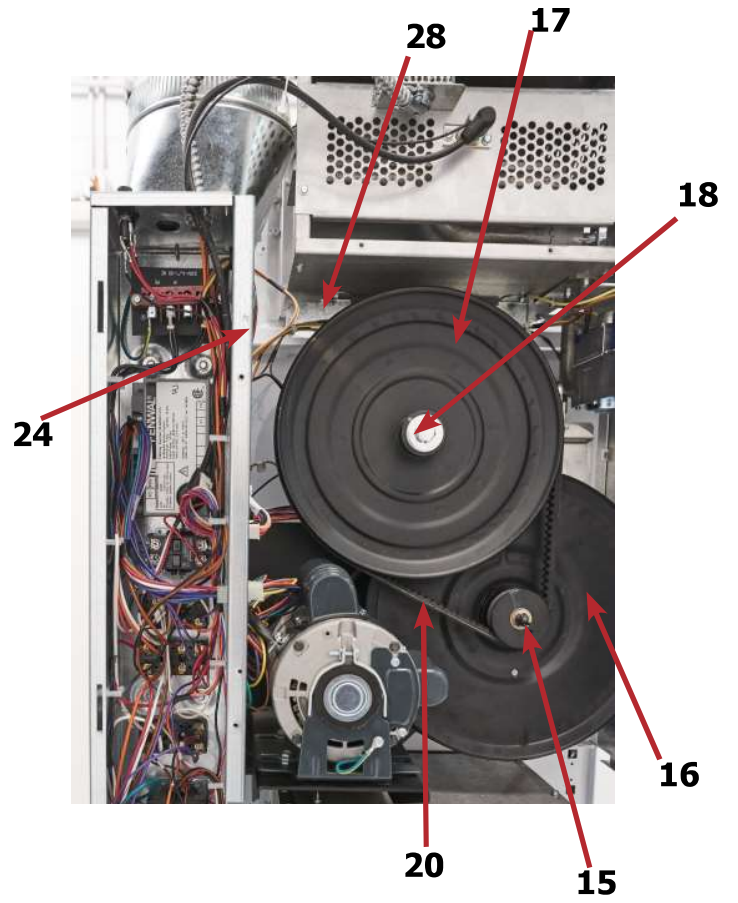
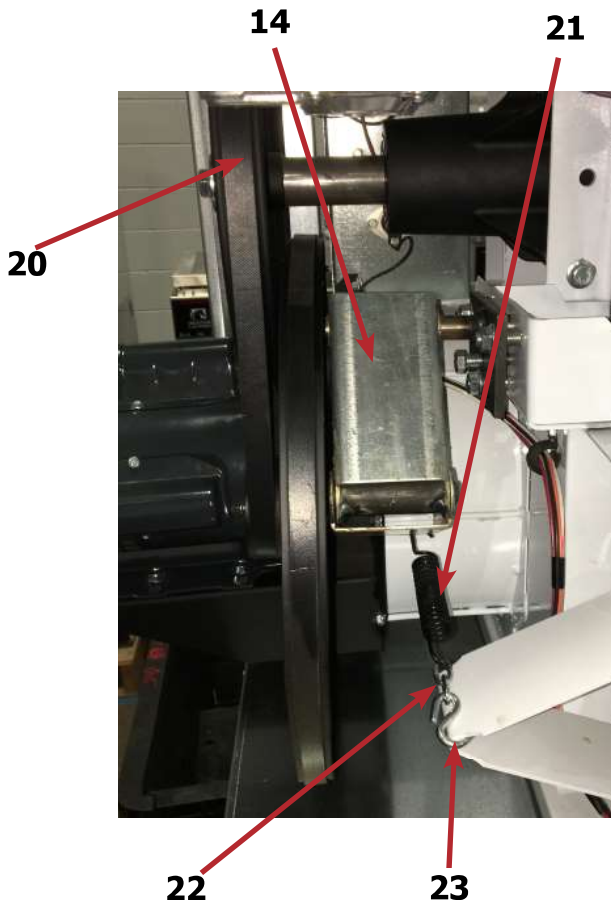

Dryer Back Panels and Guards

Key	Description	Part Number	Qty
1	Guard, Drive	9208-144-001	2
2	Screw, 10AB x 3/8	9545-008-024	39
3	Panel, Drive Guard,	9208-131-001	3
4	Guard-Small, upper	9208-134-001	1
5	Guard-Small,lower	9208-143-001	1
6	Guard-side,lower	9208-132-001	2
7	Warning, Label	8502-763-001	1
8	Label, Instructions	8502-645-001	1
9	Lighting and Clearance, Label	8527-112-001	1
10	Duct, Transition	9109-131-001	1
11	Door, Cover-Control Box	9108-146-001	1
*	Screw-hxwshrundrcuthd,10abx3/8	9545-008-024	3
12	Cabinet, Cover	9074-374-001	1
*	Insulation	9277-041-028	1
*	Wiring Diagram & Schematic	9506-836-001	1
13	Bracket-back Panel	9029-211-001	1
*	Screw, 10AB x 3/8	9545-008-024	2
14	Label-quality	8511-001-002	1
15	Cover-hi Limit	9074-329-001	2
16	Housingassy-burner,upper	9803-221-001	1
17	Housingassy-burner,lower	9803-221-002	1
18	Cover-duct,lower	9074-383-001	1

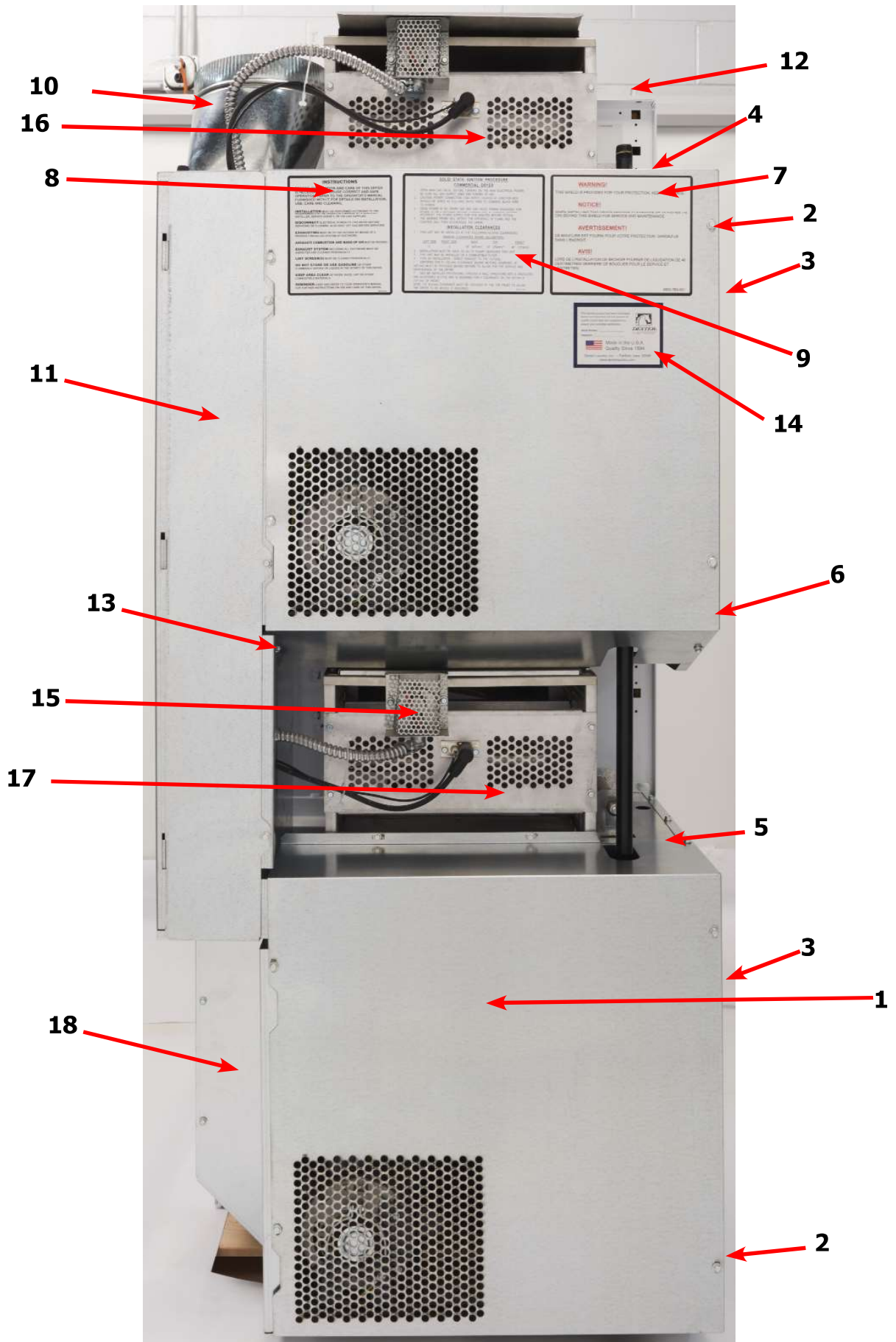

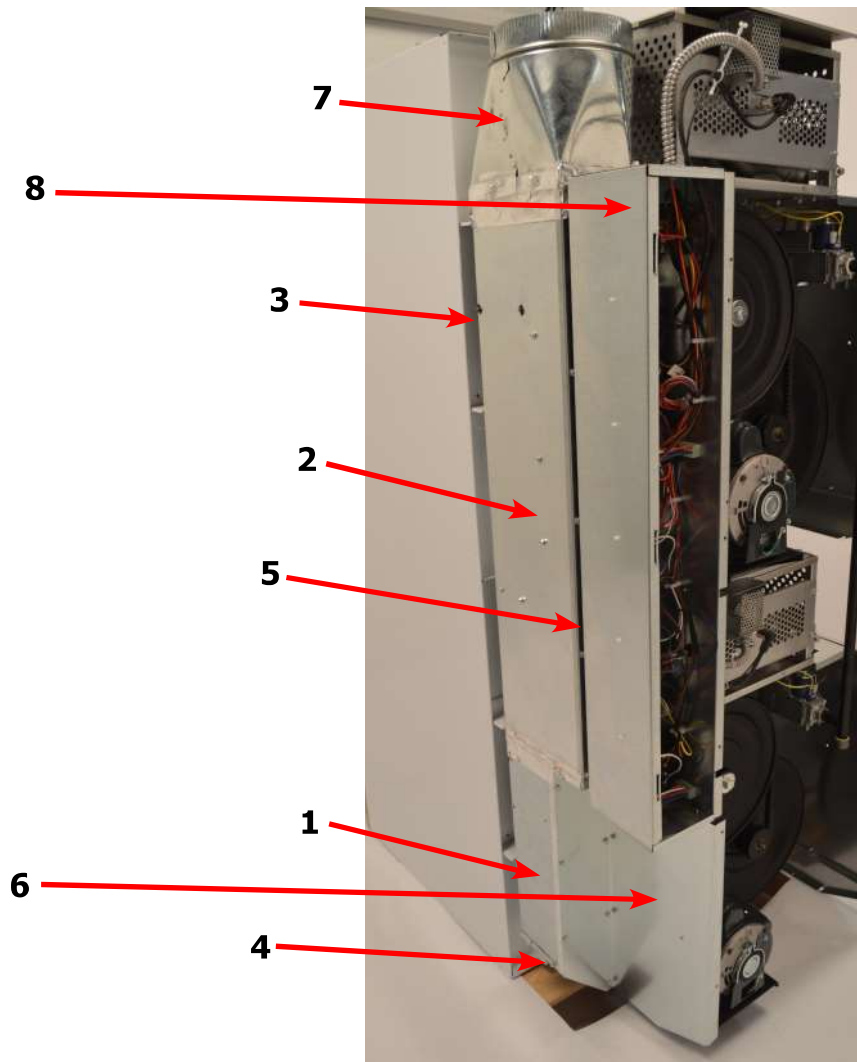

Key	Description	T-20x2	QTY
1	Box-duct.lower	9041-113-001	1
2	Box-duct,upper	9041-115-001	1
*	Screw-hxwshrhdundct,#10bx1/2	9545-008-026	8
*	Baffle-duct	9049-117-001	1
*	Deflector-duct	9114-054-001	1
3	Damper-duct	9125-009-001	2
*	Pin-hinge,damper	9451-146-007	2
*	Nut-spring	8520-141-000	4
*	Screw-hxwshrhdundct,#10bx1/2	9545-008-026	4
*	Gasket-exhaust,1/8x1/4	9206-428-002	1
4	Base-duct	9047-121-001	1
5	Cover-duct,upper	9074-382-001	1
6	Cover-duct,lower	9074-383-001	1
7	Duct-transition	9109-131-001	1
*	Screw-hxwshrundrcuthd,10abx3/8	9545-008-024	59
8	Cntlasy-ign,t-20x2,gas,coin-15	9857-250-001	1

Air Flow Switch Assembly

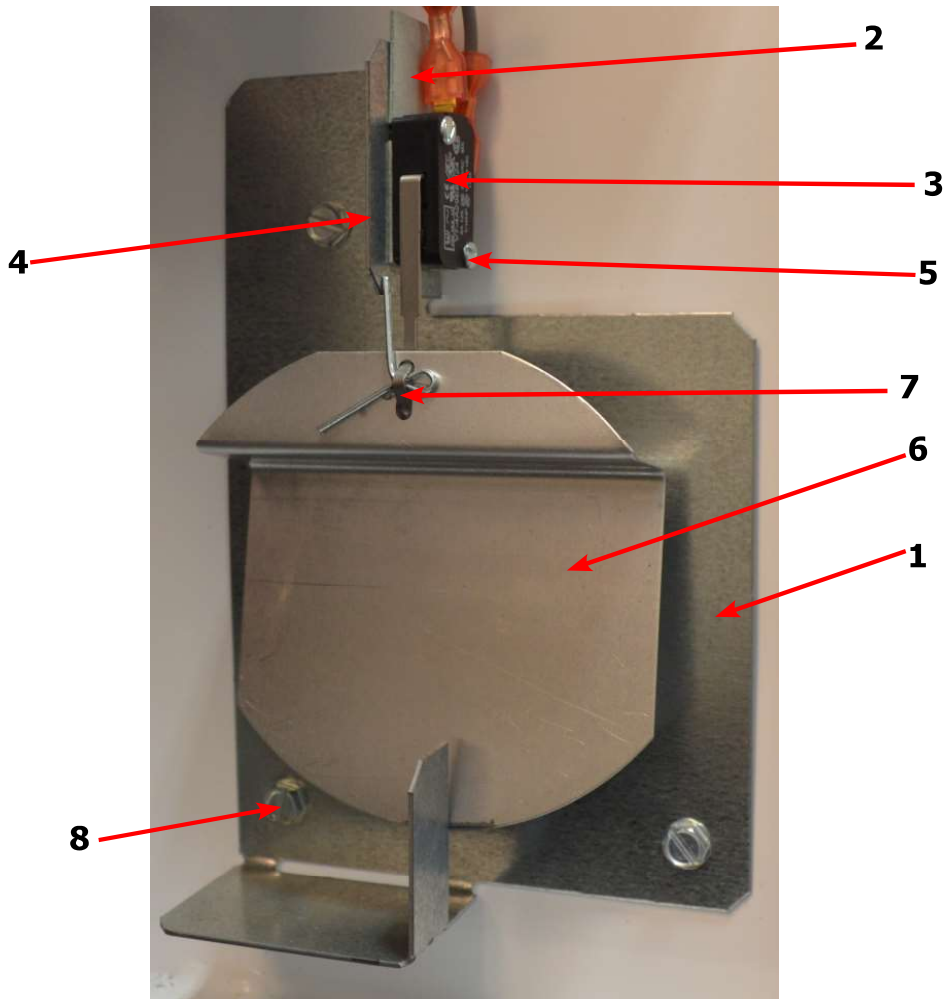

Key	Description	T-20x2	QTY
*	Air Flow switch Assy	9801-095-001	2
1	Bracket-Airflow switch	9029-174-001	2
2	Shield-Switch	9550-169-003	2
3	Switch-Micro	9539-461-009	2
4	Nut-Twin, 4-40	8640-401-001	2
5	Screw-.625, 4-40	9545-020-001	2
6	Actuator-Air Flow Switch	9008-007-001	2
7	Pin-Cotter, .09375x.75	9451-169-002	2
8	Screw, 10 B x 1/4	9545-008-001	3
*	Wireasy-brn,#13,34"	8220-063-032	1
*	Wireasy-org,#14,24"	8220-095-040	1
*	Wireasy-vio,54"	8220-103-001	1

Key	Description	T-20X2	QTY
*	Control, Rear	9857-250-001	1
1	Wrapper-controlbox	9636-219-001	1
2	Panel-upper,controlbox	9454-974-001	1
3	Panel-lower,controlbox	9454-973-001	1
*	Screw-hxwshrundrcuthd,10abx3/8	9545-008-024	6
4	Wireasy-grn/yel,7"	8220-137-002	1
*	Screw-hxwsrhds1,10-32tx1/2grn	9545-008-027	1
*	Lock washer-exttooth,#10	8641-582-006	1
5	Terminal block assembly-power	9897-026-002	1
6	Terminal block assembly-power	9897-026-001	2
*	Screw-panhdcr,#8abx1/2	9545-045-012	6
7	Transformer	8711-013-001	1
*	Screw-hxwshrundrcuthd,10abx3/8	9545-008-024	4
8	Controls assy-ignition	9857-182-001	2
*	Screw-hxwshd,10abx3/4	9545-008-018	4
9	Wireasy-high voltage,#8,18 1/2"	9631-403-008	1
10	Wireasy-high voltage,#7,29 1/4"	9631-403-009	1
11	Wiring harness-ignitioncontrol Upper	9627-867-005	1
12	Wiring harness-ignition control lower	9627-867-006	1
*	Plug-plastic,7/8"	9456-041-006	2
*	Bushing-wire,7/8	9053-067-002	4
*	Connector-conduit,3/8",str	8653-068-003	1
13	Fuse holder assembly	9200-001-002	3
*	Fuse-1.5a,fast,1/4x1-1/4	8636-018-001	2
*	Fuse-2.5a,fast,1/4x1-1/4	8636-018-004	1
14	Relay-motor,30amp,24vac	5192-299-002	2
*	Screw-panhdcr,#8abx1/2	9545-045-012	4
*	Wireasy-red/blk,#9,14"	8220-062-036	1
*	Wireasy-red/wht,#10,14"	8220-062-037	1
*	Wireasy-wht,#11,14"	8220-062-038	2
15	Bracket-power block	9029-202-001	1
*	Screw-hxwshrundrcuthd,10abx3/8	9545-008-024	2
*	Terminal block asy-power,4pole	9897-035-001	1
*	Screw-hxwshrundrcuthd,10abx3/8	9545-008-024	2
*	Strip-marker,terminal	9558-029-003	1
16	Wiring harness-power,main,fork	9627-859-003	1
17	Wiring harness-mainex tension	9627-863-001	1
18	Standoff-wires addlew/arrowhead	9527-007-001	22
19	Wiring harness-motor ext,w/fork Lower	9627-864-006	1
20	Wiring harness-motor extension Upper	9627-864-011	1
*	Screw-pnhdcr,6bx3/8	9545-031-005	4
*	Screw-hxwsrhds1,10-32tx1/2grn	9545-008-027	2
*	Lockwasher-exttooth,#10	8641-582-006	2
21	Wireasy-red,37"	8220-095-011	1
22	Wireasy-blu,42"	8220-095-012	1
23	Wireasy-wht,22"	8220-095-048	1
24	Wireasy-blk,#30,45"	8220-095-046	1

Control Assembly Group

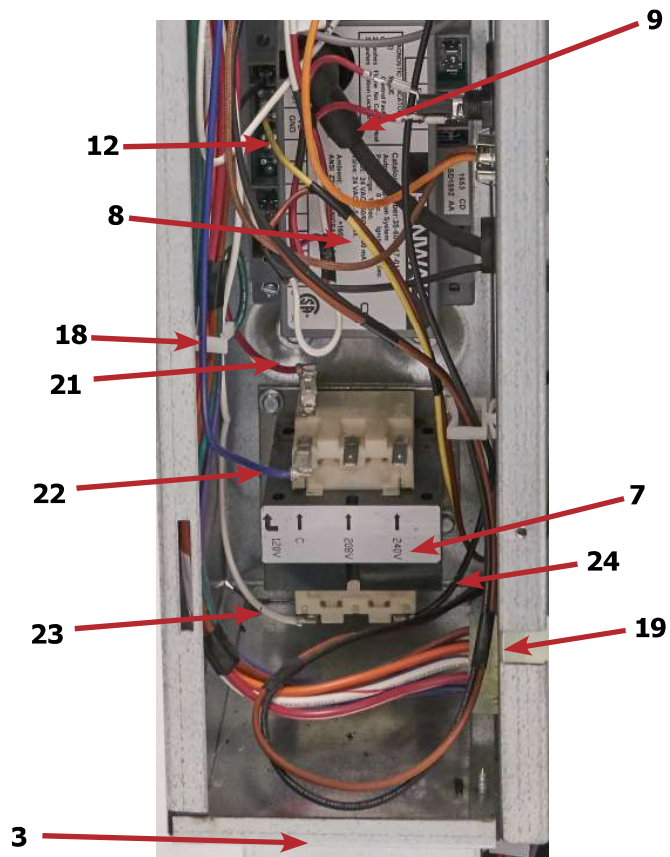
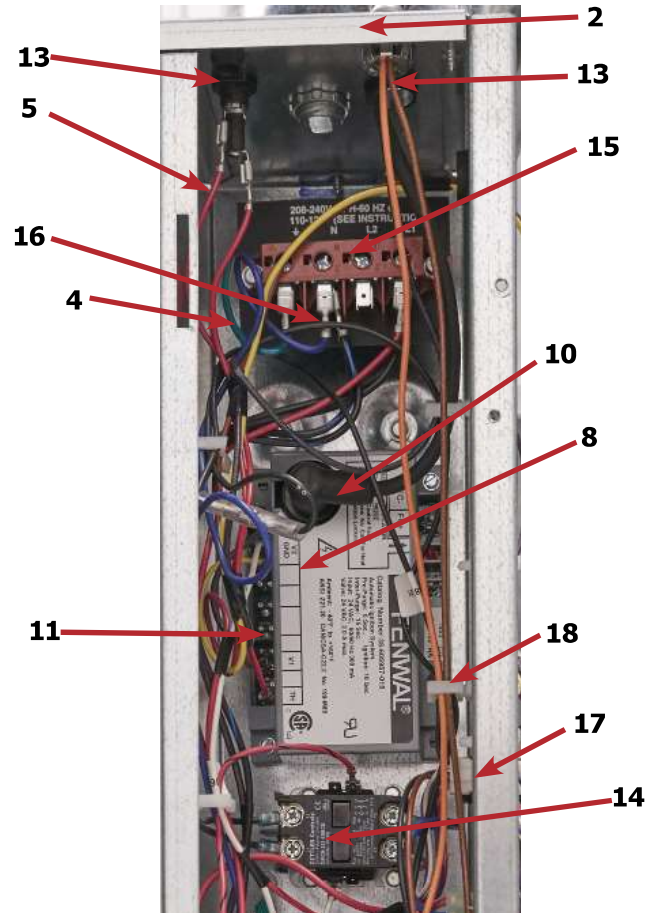
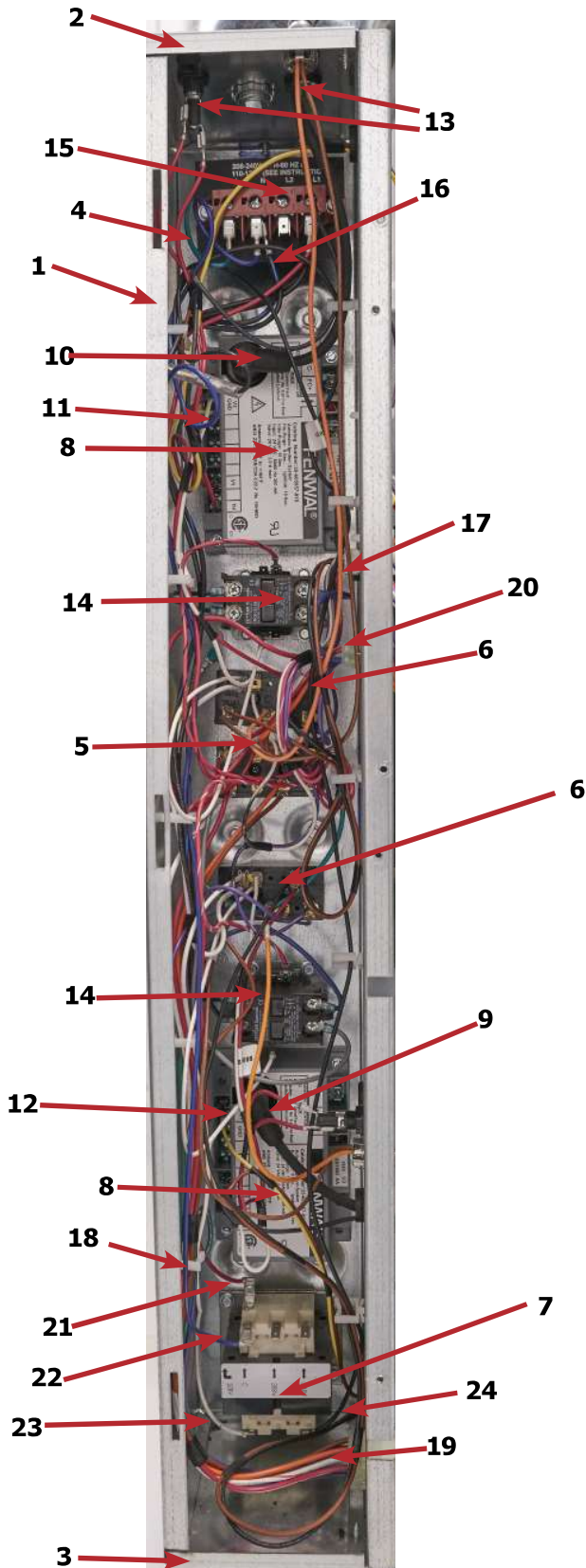

Wire Harness

Key	Description	T-20x2	QTY
*	Wireharness-overtmp/airswitch	9627-861-002	2
*	Wireharness-main,dry,t-20x2	9627-911-006	1
*	Wiringharness-heatsensor	9627-855-003	1
*	Wireasy-org,37"	8220-095-049	1
*	Wireasy-brn,37"	8220-095-050	1
*	Wireasy-org,#14,24"	8220-095-040	1
*	Wireasy-brn,#15,24"	8220-095-041	1
*	Wireasy-yel,47/8"	8220-001-466	2
*	Wireasy-grn/yel,#16,24"	8220-137-001	1
*	Wiringharness-ignitioncontrol	9627-867-005	1
*	Wiringharness-ignitioncontrol	9627-867-006	1
*	Wiringharness-power,main,fork	9627-859-003	1
*	Wiringharness-mainextension	9627-863-001	1
*	Wiringharness-motorext,w/fork	9627-864-006	1
*	Wiringharness-motorextension	9627-864-011	1
*	Wireasy-grn/yel,7"	8220-137-002	1
*	Wireasy-red/blk,#9,14"	8220-062-036	1
*	Wireasy-red/wht,#10,14"	8220-062-037	1
*	Wireasy-wht,#11,14"	8220-062-038	2
*	Wireasy-red,37"	8220-095-011	1
*	Wireasy-blu,42"	8220-095-012	1
*	Wireasy-wht,22"	8220-095-048	1
*	Wireasy-blk,#30,45"	8220-095-046	1

Coin Handling Group

Key	Description	Part Number	Qty
	Coin Acceptor, Optical, US Quarter	9021-092-002	1
*	Retainer, Coin Acceptor	9486-149-001	1
*	Screw, Torx	9545-053-002	4
1	Switch Assembly, Optical Sensor	9801-099-003	1
*	Harness, Acceptor Mechanical (Control to Acceptor)	9627-783-003	1
*	Coin Vault	9942-038-005	1
*	Screw, 10AB X 3/8	9545-008-024	2
*	Plateasy-coinvaultmounting	9982-338-001	1

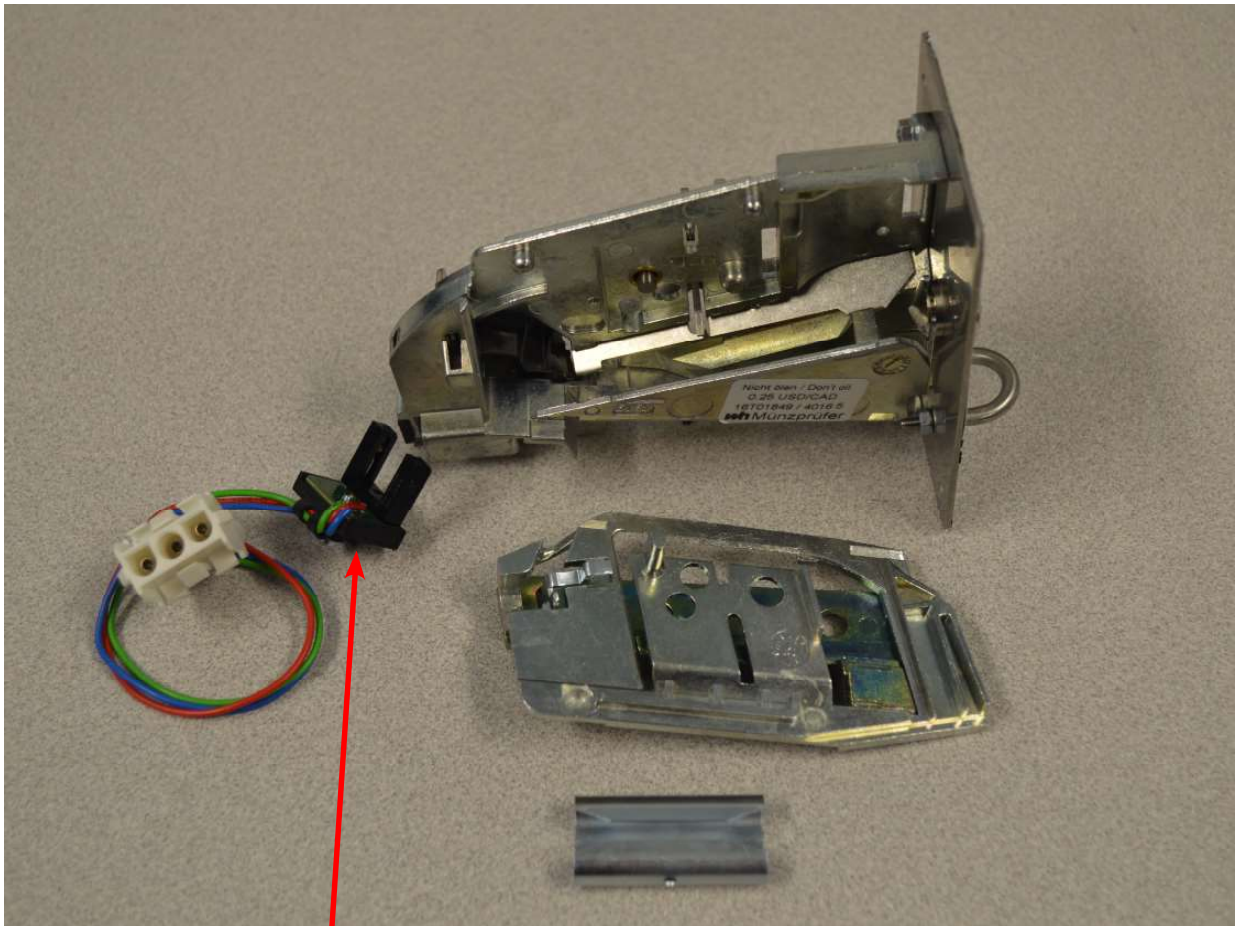

1

Wiring Diagram for DC20x2

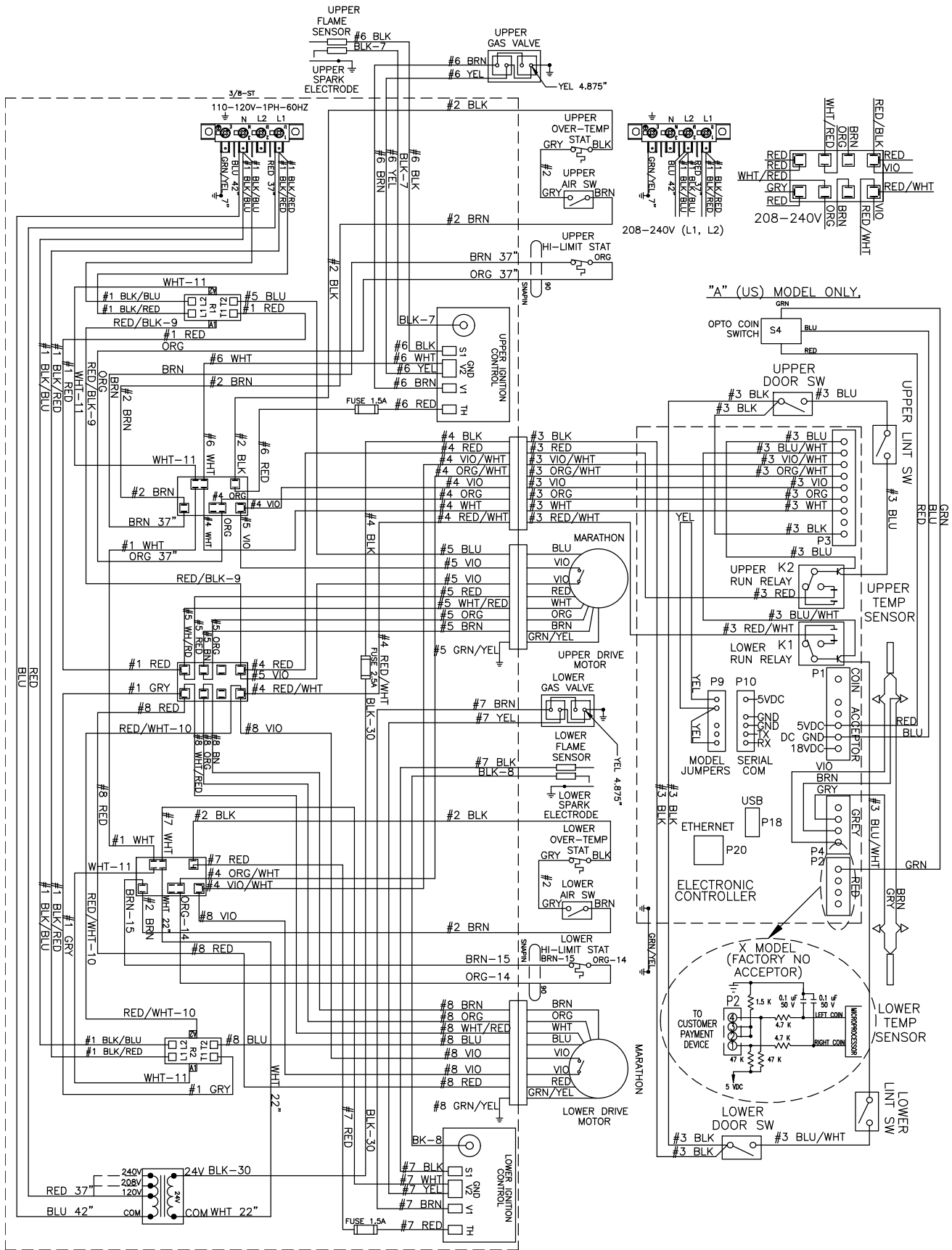

9506-836-001PR WIRING DIAGRAM DC20X2N_-15_C_X-

IMPORTANT: RETAIN THIS ELECTRICAL DIAGRAM FOR SERVICE.

Wiring Schematic for DC20x2

NOTES:

1. DOOR SWITCHES ARE N.O., SWITCHES CLOSED WHEN DOOR IS CLOSED.
2. MOTOR RUN RELAY CONTACT WILL CLOSE WHEN THE COIN COUNT IS SATISFIED, THE DOOR CLOSED AND THE START BUTTON PRESSED.
3. REFER TO OWNERS MANUAL FOR DESCRIPTION OF OPERATION AND REQUIREMENTS FOR HEATING CIRCUIT.

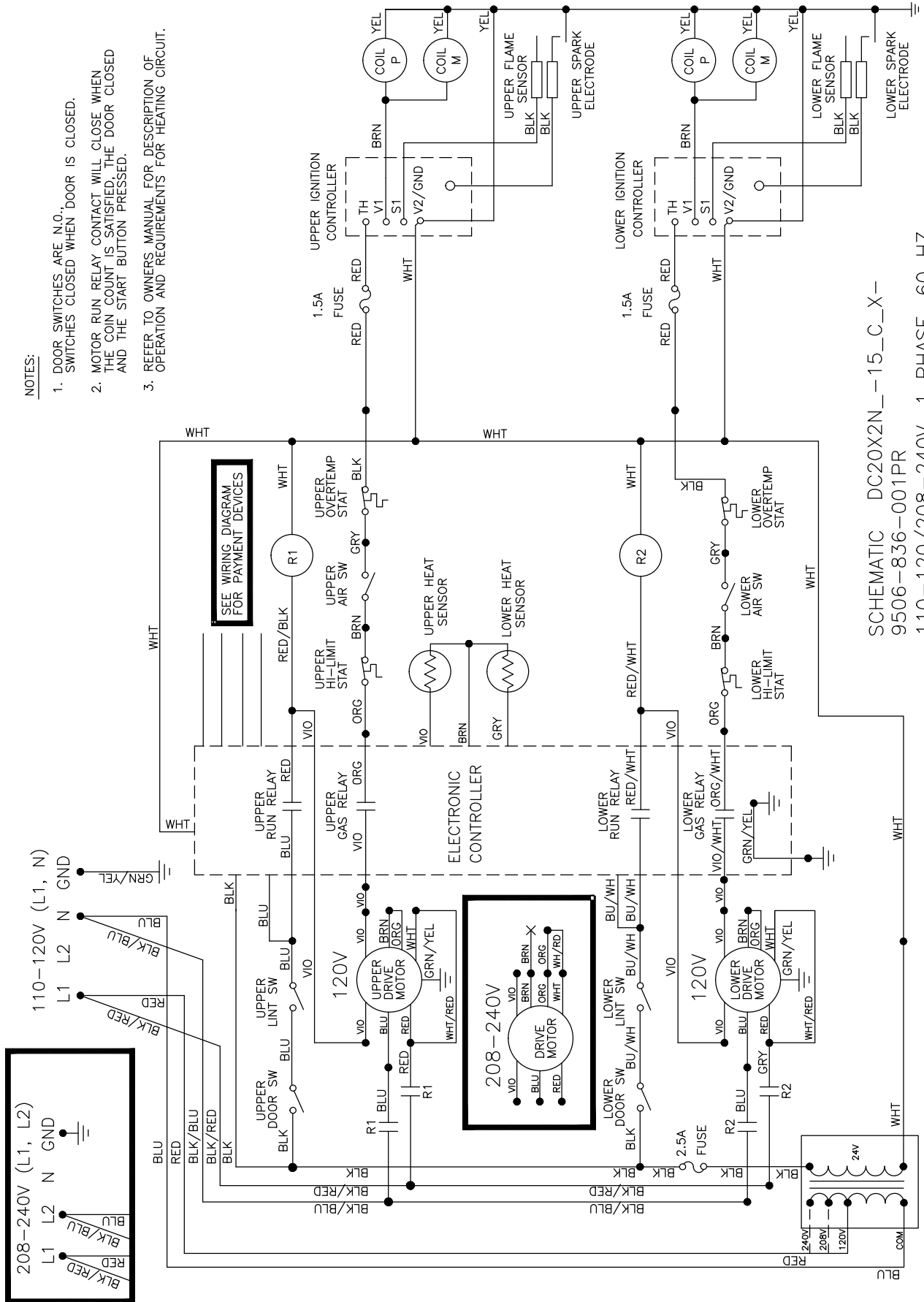

SCHEMATIC DC20X2N_15_C_X-
9506-836-001PR

110-120/208-240V, 1 PHASE, 60 HZ

IMPORTANT: RETAIN THIS ELECTRICAL SCHEMATIC FOR SERVICE.