

COMPACT 5-IN-ONE IRONING SYSTEM FOR ON-PREMISE LAUNDRIES

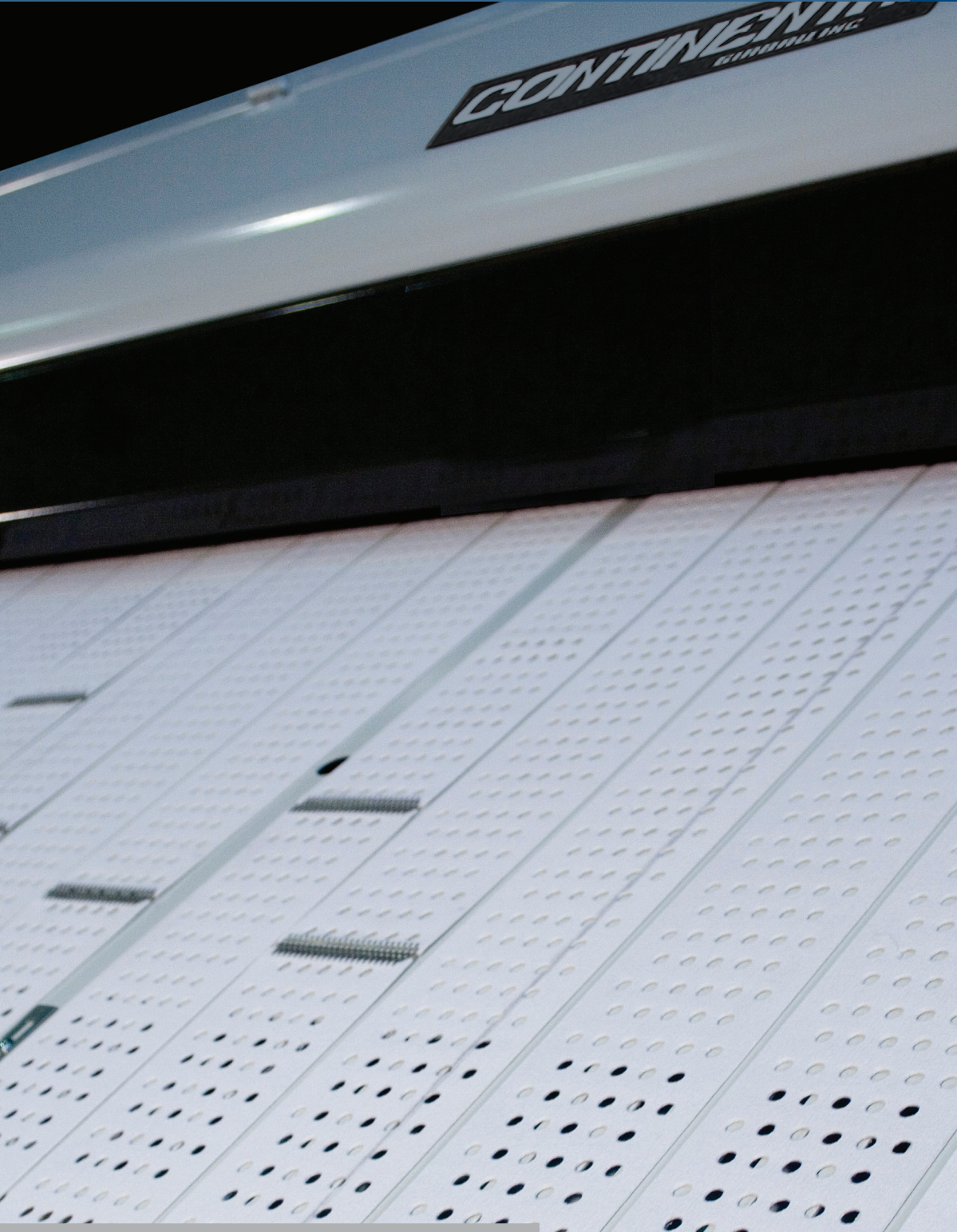

Engineered for medium- and high-volume laundries where space is at a premium, the Compact 5-in-One Ironing System not only features a compact design, it quickly feeds, irons, folds, stacks and accumulates at speeds of up to 50-feet-per-minute.



| | XC24102 | XC24130 |
|---------------------------------------|--------------|--------------|
| Cylinder Diameter | | |
| <i>inch (mm)</i> | 24 (600) | 24 (600) |
| Usable Cylinder Width | | |
| <i>inch (mm)</i> | 102.4 (2600) | 130 (3300) |
| Evaporation Capability | | |
| <i>gal/h (l/h)</i> | 18.5 (70) | 22.5 (85) |
| Ironing Speed | | |
| <i>ft/min (m/min)</i> | 9-32(3-10) | 9-32(3-10) |
| Net Weight | | |
| <i>lbs (kg)</i> | 4740 (2150) | 5071 (2300) |
| Machine Width <i>inch (mm)</i> | | |
| <i>no stacker</i> | 137 (3480) | 161.4 (4100) |
| <i>with stacker</i> | 187 (4750) | 211.4 (5370) |
| Machine Depth | | |
| <i>no stacker</i> | 81.9 (2080) | 81.9 (2080) |
| <i>with stacker</i> | 113 (2870) | 113 (2870) |
| Machine Height | | |
| <i>inch (mm)</i> | 70.9 (1800) | 70.9 (1800) |
| Electrical Consumption | | |
| <i>kW (Hp)</i> | 3.7 (5) | 3.7 (5) |
| Exhaust Diameter (2) | | |
| <i>inch (mm)</i> | 5 (127) | 5 (127) |
| Gas Heating | | |
| <i>BTU/h</i> | 266,000 | 318,000 |
| Compressed Air Flow | | |
| <i>gal/min</i> | 135 | 135 |

| | XC32102 | XC32130 |
|---------------------------------------|--------------|--------------|
| Cylinder Diameter | | |
| <i>inch (mm)</i> | 32 (800) | 32 (800) |
| Usable Cylinder Width | | |
| <i>inch (mm)</i> | 102.4 (2600) | 130 (3300) |
| Evaporation Capability | | |
| <i>gal/h (l/h)</i> | 23.8 (90) | 31.7 (120) |
| Ironing Speed | | |
| <i>ft/min (m/min)</i> | 9-49(3-15) | 9-49(3-15) |
| Net Weight | | |
| <i>lbs (kg)</i> | 5401 (2450) | 8047 (3650) |
| Machine Width <i>inch (mm)</i> | | |
| <i>no stacker</i> | 141.7 (3600) | 166.1 (4220) |
| <i>with stacker</i> | 191.7 (4870) | 216.1 (5490) |
| Machine Depth | | |
| <i>no stacker</i> | 89.4 (2270) | 89.4 (2270) |
| <i>with stacker</i> | 113 (2870) | 113 (2870) |
| Machine Height | | |
| <i>inch (mm)</i> | 80.8 (2050) | 80.8 (2050) |
| Electrical Consumption | | |
| <i>kW (Hp)</i> | 4.1 (5.5) | 4.1 (5.5) |
| Exhaust Diameter (2) | | |
| <i>inch (mm)</i> | 5 (127) | 5 (127) |
| Gas Heating | | |
| <i>BTU/h</i> | 354,000 | 424,500 |
| Compressed Air Flow | | |
| <i>gal/min</i> | 135 | 135 |

COMPACT 5-IN-ONE IRONING SYSTEM
FEEDER • IRONER • FOLDER • STACKER • ACCUMULATOR

It's like nothing else. The Continental Compact 5-in-One Ironing System delivers a compact design and superior flexibility that allows medium- and high-production laundries to quickly feed, iron, fold, stack and accumulate a variety of items using up to four lanes. This space-saving system generates processing speeds of up to 50-feet-per-minute; is available in 24- and 32-inch diameters with 102- and 130-inch finishing widths; and uses natural gas or liquid propane (LP) heat.

FLEXIBILITY IN SMALL SPACES

The Compact 5-in-One eliminates the need to have multiple machines to achieve high-quality finishing. Engineered for maximized productivity where space is tight, the 5-in-One delivers unsurpassed results in less time using less space.

MULTI-FUNCTION CAPABILITY & CONFIGURABILITY

The vacuum-assisted feeding table, a unique option offered on the Compact 5-in-One, simplifies linen feeding, maximizes production and processing speeds, and ensures high-quality results. As items are fed into the Compact 5-in-One, an optional spreader/feeder straightens and spreads items for increased productivity. The ironer automatically adjusts ironing speed and temperature based on the moisture content of the item—ensuring a quality finish. The built-in folder performs one to two length-wise folds, and one, two or three cross folds to meet specific needs. An optional stacker, available for both left and right output, further boosts productivity.

FOLDING FLEXIBILITY FOR SPECIFIC NEEDS

Configurable for one, two, or four working lanes, with one lane for sheets, two for table linens and four for small items, including napkins and pillow cases, the Compact boasts unrivaled flexibility. It delivers standard, four-lane primary folds and single or two-lane cross folds using air jets, reversing conveyors and knife blade assistance. A bypass option allows goods to exit the front or rear of the machine and an optional two or four-lane draping accumulator is available for small-piece goods.

SUPERIOR PROGRAMMABILITY & EASE OF USE

Equipped with an intuitive control offering 20 pre-set and 20 customizable programs, the Compact 5-in-One provides touch-screen control over ironing parameters, faults, alarms or alterations in processing and diagnostics. The control seamlessly interacts with optional equipment ensuring unsurpassed ease of use, flexibility for multiple items, and control over item type. Operators select a program number and press start. A quick push of a button by operators automatically rejects stained or torn items, and a wide, inclined feeding table provides a better view of items while feeding.

THREE INDEPENDENT HEATING ZONES

A highly efficient machine, the Compact 5-in-One maintains three temperature zones and a modulating heat system within the roll, always ensuring roll temperature is properly regulated for consistent heat and maximized efficiency. These modulating heat zones deliver up to a 30 percent energy savings—cutting utility costs.

BUILT FOR CONSTANT USE

Engineered for constant use and long life, the Compact offers easy maintenance, including a self-cleaning exhaust fan, and an industry leading 7/5/3-year warranty.

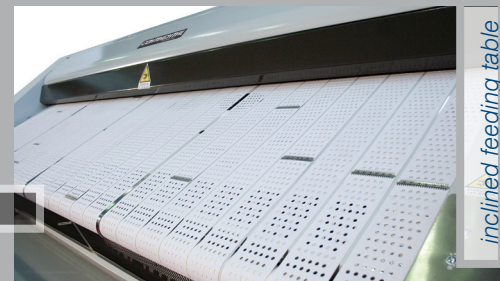

inclined feeding table

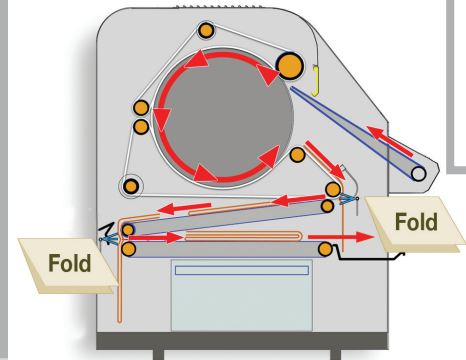

folding flexibility

Standard Configuration:
No bypass, 2 folds long

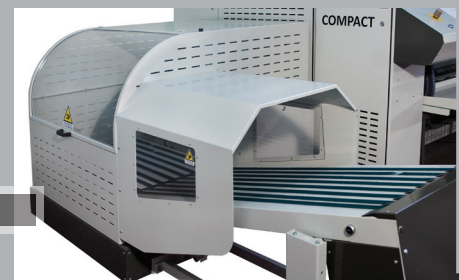

right or left output stacker



intuitive control



(3) modulating heat zones

* Product specifications are temporary. Please verify before final installation. Specifications subject to change without notice or obligation. Call Continental Girbau for dimensions not shown or for clarification.

CONTINENTALCARE™
 BUY WITH COMPLETE CONFIDENCE

3-YR LIMITED PARTS WARRANTY
 5-YR KEY COMPONENT WARRANTY
 7-YR ROLL & CHEST WARRANTY

DISTRIBUTED BY:



800-256-1073

www.continentalgirbau.com

2500 State Road 44 • Oshkosh, WI 54904
 920-231-8222 • Fax 920-231-4666